



215E

Operator and Parts Manual

(Operator Manual)



MM158



This manual is furnished with each new TENNANT Model 215E

This manual consists of Specifications; Operation; Maintenance; Appendix; the How To Use This Manual; Low Dump Model Parts; Multi-Level Dump Model Parts; Options; Hydraulic Components; and Cross Reference sections.

MACHINE DATA

Please fill out at time of installation for future reference.

Machine Model Number – 215E

Machine Serial Number – _____

Machine Options – _____

TENNANT Representative/phone no. – _____

Customer ID Number – _____

Date of Installation – _____

Manual Number – MM158

Revision: 11

Published: 2-98

SAFETY PRECAUTIONS

The following symbols are used throughout this manual as indicated in their descriptions:



WARNING: To warn of hazards or unsafe practices which could result in severe personal injury or death.

FOR SAFETY: To identify actions which must be followed for safe operation of equipment.

The following information signals potentially dangerous conditions to the operator or equipment. Read this manual carefully. Know when these conditions can exist. Locate all safety devices on the machine. Then, take necessary steps to train machine operating personnel. Report machine damage or faulty operation immediately. Do not use the machine if it is not in proper operating condition.

FOR SAFETY:

1. **Do Not Operate Machine:**
 - Unless Trained And Authorized.
 - Unless Operation Manual Is Read And Understood.
 - In Flammable Or Explosive Areas Unless Designed For Use In Those Areas.
 - In Areas With Possible Falling Objects Unless Equipped With Overhead Guard.
2. **Before Starting Machine:**
 - Make Sure All Safety Devices Are In Place And Operate Properly.
 - Check Brakes And Steering For Proper Operation.
3. **When Starting Machine:**
 - Keep Foot On Brake And Directional Pedal In Neutral.
4. **When Using Machine:**
 - Use Brakes To Stop Machine.
 - Go Slow On Grades And Slippery Surfaces.
 - Use Care When Backing Machine.
 - Move Machine With Care When Hopper Is Raised.
 - Make Sure Adequate Clearance Is Available Before Raising Hopper.
 - Do Not Carry Riders On Machine.
 - Always Follow Safety And Traffic Rules.

5. **Before Leaving Or Servicing Machine:**
 - Stop On Level Surface.
 - Set Parking Brake.
 - Turn Off Machine And Remove Key.
6. **When Servicing Machine:**
 - Avoid Moving Parts. Do Not Wear Loose Jackets, Shirts, Or Sleeves When Working On Machine.
 - Block Machine Tires Before Jacking Machine Up.
 - Jack Machine Up At Designated Locations Only. Block Machine Up With Jack Stands.
 - Use Hoist Or Jack Of Adequate Capacity To Lift Machine.
 - Wear Eye And Ear Protection When Using Pressurized Air Or Water.
 - Disconnect Battery Connections Before Working On Machine.
 - Avoid Contact With Battery Acid.
 - Use Cardboard To Locate Leaking Hydraulic Fluid Under Pressure.
 - Use TENNANT Supplied Or Equivalent Replacement Parts.



WARNING: Batteries Emit Hydrogen Gas. Explosion Or Fire Can Result. Keep Sparks And Open Flame Away. Keep Covers Open When Charging.



WARNING: Raised Hopper May Fall. Engage Hopper Support Bar.

GENERAL INFORMATION

The following safety labels are mounted on the machine in the locations indicated. If these, or any label becomes damaged or illegible, install a new label in its place.

BATTERY CAUTION LABEL - LOCATED ON THE OPERATOR SIDE OF THE FRONT SUPPORT PARTITION.

CAUTION

Explosive Gas Is Given Off By Batteries During Charge.

1. Keep Battery Compartment Cover Open.
2. No Smoking, Flame Or Sparks In Area.
3. Charge Only In Well Ventilated Area.
4. See Operators Manual Before Charging. Overcharging May Reduce Battery Life.

12728

HOPPER SUPPORT BAR WARNING LABEL - LOCATED ON THE HOPPER SUPPORT BAR

WARNING

Engage Safety Support Bar Per Instructions Before Working Under Hopper.

INSTRUCTIONS

To Engage Safety Support Bar:

1. Lift Hopper To Extreme Up Position.
2. Set Parking Brake.
3. Disengage Machine. Engage Safety Support Bar Against Stop On Frame.
4. Lower Hopper On To Support Bar.
5. Shut Off Machine.

SAFETY SUPPORT BAR

10791



WARNING

Engage Safety Support Bar Per Instructions Before Working Under Hopper.

INSTRUCTIONS

To Engage Safety Support Bar:

1. Lift Hopper To Extreme Up Position.
2. Set Parking Brake.
3. Disengage Machine. Engage Safety Support Bar Against Stop On Frame.
4. Lower Hopper On To Support Bar.
5. Shut Off Machine.

SAFETY SUPPORT BAR

10791

WARNING LABEL - LOCATED ON THE HOPPER SIDE OF THE FRONT SUPPORT PARTITION.

FOR SAFETY

1. Do Not Operate Machine:
 - Unless Trained And Authorized.
 - Unless Operation Manual Is Read And Understood.
 - In Flammable Or Explosive Areas.
 - In Poorly Ventilated Areas.
2. Do Not Raise Hopper Without First Raising Main And Side Brush.
3. Do Not Use Flammable Cleaning Agents.
4. Check For Fuel Leaks.
5. Do Not Drive On Grades And Slippery Surfaces.
6. Before Leaving Machine:
 - Stop On Level Surface
 - Stop Engine And Set Parking Brake
 - When Parking, Remove Key.
7. Use Tennant Company Supplied Or Equivalent Replacement Parts.

12729

FOR SAFETY LABEL - LOCATED ON THE SEAT SHROUD.

WARNING

Engage Safety Support Bar Per Instructions Before Working Under Hopper.

INSTRUCTIONS

To Engage Safety Support Bar:

1. Lift Hopper To Extreme Up Position.
2. Set Parking Brake.
3. Disengage Machine. Lower Safety Support Bar And Insert Into Slot.
4. Lower Hopper On To Support Bar.
5. Shut Off Machine.

SAFETY SUPPORT BAR

10792

HOPPER SUPPORT BAR WARNING LABEL - LOCATED ON THE OPERATOR SIDE OF THE HOPPER.

07193

SECTION 1**CONTENTS**

	Page
MACHINE SPECIFICATIONS	1-3
POWER TYPE	1-3
POWER TRAIN	1-3
STEERING	1-3
HYDRAULIC SYSTEM	1-3
BRAKING SYSTEM	1-3
SUSPENSION SYSTEM	1-3
SYSTEM FLUID CAPACITIES	1-3
GENERAL MACHINE DIMENSIONS - CAPACITIES	1-3
MACHINE WEIGHTS	1-3
GENERAL MACHINE PERFORMANCE	1-3
MACHINE DIMENSIONS	1-4

MACHINE SPECIFICATIONS**POWER TYPE**

Electric propelling motor- nominal voltage 36
VDC 1.9 hp (0.14 kW) @ 320 rpm, 50 A
Batteries, standard (6) - 6 V, 220 A/h @ 20 hour
rate
heavy duty (6) - 6 V, 305 A/h @ 20 hour rate
Battery charger - 36 VDC 20 A, 120 VAC input
24 VDC, 15 A, 115/230 VAC

POWER TRAIN

Propelling - hydrostatic transmission, belt driven
Differential - chain driven
Drive axle (2) - chain driven
Main brush - belt driven
Side brush - belt driven
Vacuum fan - belt driven
Hydraulic pump - electric motor driven

STEERING

Type - rear wheel controlled, automotive cam
and lever
Power source - manual

HYDRAULIC SYSTEM

Function - operates hopper lift on multi-level
dump model
Control valve - solenoid operated, pump
mounted
Pump - gear type, 0.065 cu in (1 cc)
displacement per revolution, 1250 psi
(8620 kPa) @ 1.0 gpm (4 L/min)
relief setting
Cylinder - single action type, 2 in (50 mm) bore x
11 in (280 mm) stroke, 1 in (25 mm)
diameter rod, 2500 psi (17,240 kPa)
maximum rated pressure.

BRAKING SYSTEM

Service brakes - mechanical disc brakes (2) -
1 per front wheel, cable actuated
Parking brakes - utilizes service brakes, cable
actuated

SUSPENSION SYSTEM

Front - 12 x 3.00 zero pressure tires (2)
Rear - 12 x 3.00 solid tire (1)

SYSTEM FLUID CAPACITIES

Hydrostatic transmission - 1.6 pt (0.75 L)
Hydraulic system - reservoir 2 qt (1.8 L)
Hydraulic system - total 2.5 qt (2.4 L)

**GENERAL MACHINE DIMENSIONS -
CAPACITIES**

Length - 63.75 in (1620 mm)
Width - 46.75 in (1190 mm) with side brush
Height - 53.75 in (1365 mm) less overhead
guard
Height - 79 in (2005 mm) with overhead guard
Track - front 42 in (1065 mm)
Wheel base - 35.5 in (900 mm)
Main brush - width 36 in (915 mm)
Main brush - outside diameter 10 in (255 mm)
Side brush - rotary diameter 17 in (430 mm)
Sweeping path width (total) - 46 in (1170 mm)
Hopper capacity - 6 cu ft (0.17 m³)
320 lb (145 kg)
Dust filter - 42 sq ft (3.9 m²), pleated panel
filter element

MACHINE WEIGHTS

Net weight, dry - 1060 lb (480 kg)
GVWR - 2205 lb (1000 kg)

GENERAL MACHINE PERFORMANCE

Maximum forward speed - 4.5 mph (7 km/h)
Maximum reverse speed - 2 mph (3 km/h)
Turning radius - 67 in (1700 mm)

MACHINE DIMENSIONS

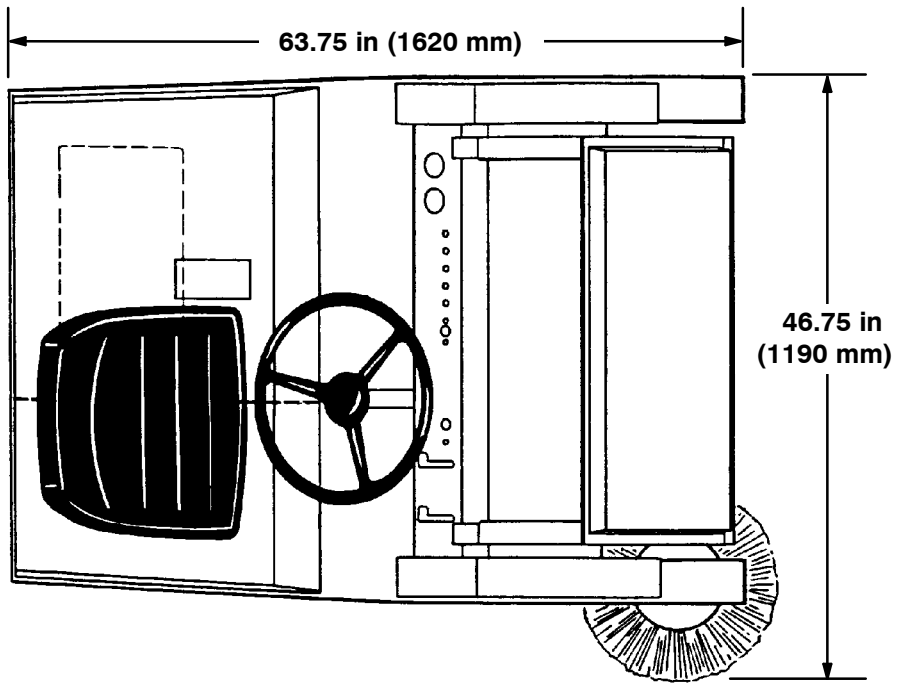

TOP VIEW

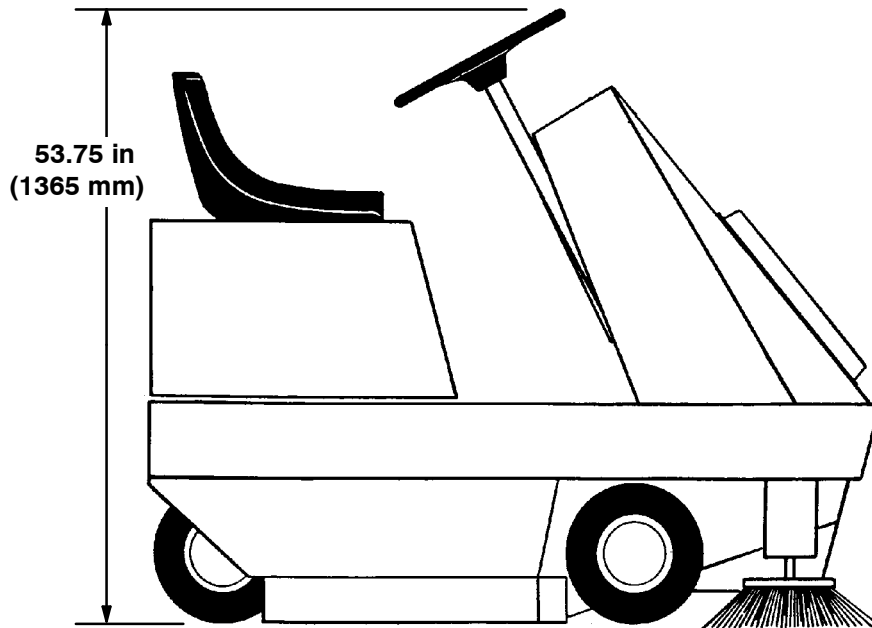

SIDE VIEW

07194

SECTION 2

CONTENTS

	Page		Page
PREPARATION FOR OPERATION	2-3	MACHINE OPERATION	2-11
AFTER UNCRATING AND BEFORE		NORMAL SWEEPING OPERATION ...	2-11
OPERATING MACHINE:	2-3	PRE-START CHECKLIST	2-11
OPERATION OF CONTROLS	2-4	TO START MACHINE	2-11
MACHINE COMPONENTS	2-4	TO SWEEP	2-11
INSTRUMENT PANEL SYMBOLS	2-5	TO DUMP HOPPER	2-12
CONTROLS AND INSTRUMENTS	2-6	POST OPERATION CHECKLIST -	
BRAKE PEDAL	2-7	MOTOR OPERATING	2-12
DIRECTIONAL PEDAL	2-7	TO STOP MACHINE	2-12
PARKING BRAKE LEVER	2-7	POST OPERATION CHECKLIST -	
CHARGER TIMER	2-7	MOTOR STOPPED	2-12
CHARGER GAUGE	2-7	OPERATION ON GRADES	2-12
BATTERY DISCHARGE INDICATOR ..	2-7	MACHINE TROUBLESHOOTING	2-13
VOLTMETER	2-7	TRANSPORTING MACHINE	2-14
HOUR METER	2-7	PUSHING OR TOWING MACHINE	2-14
HAZARD LIGHT SWITCH	2-7	MACHINE JACKING	2-14
LIGHTS SWITCH	2-8	TO JACK UP MACHINE	2-14
FILTER SHAKER SWITCH	2-8	MACHINE TIE-DOWNS	2-15
HOPPER DOOR SWITCH	2-8	MACHINE STORAGE	2-16
HOPPER SWITCH	2-8	STORING MACHINE	2-16
HORN BUTTON	2-8		
KEY-OPERATED ON-OFF SWITCH ...	2-8		
START SWITCH	2-8		
MAIN BRUSH POSITION LEVER	2-8		
SIDE BRUSH POSITION LEVER	2-8		
STEERING WHEEL	2-8		
MAIN BRUSH HEIGHT ADJUSTMENT			
KNOB	2-9		
CHARGER PANEL	2-9		
CIRCUIT BREAKERS AND FUSES	2-9		
HOPPER SUPPORT BAR	2-10		
TO ENGAGE HOPPER			
SUPPORT BAR	2-10		
TO DISENGAGE HOPPER			
SUPPORT BAR	2-10		

PREPARATION FOR OPERATION

AFTER UNCRATING AND BEFORE OPERATING MACHINE:

1. Check the machine for shipping damage.
2. Read this manual carefully before operating or servicing the machine.

FOR SAFETY: Do Not Operate Machine, Unless Operation Manual Is Read And Understood.

3. Open the seat support.
4. Check the batteries. If they are of the wet-type, check the electrolyte level. If they are of the dry-type, activate them as described in *ACTIVATING DRY-TYPE BATTERIES* in the *MAINTENANCE* section.

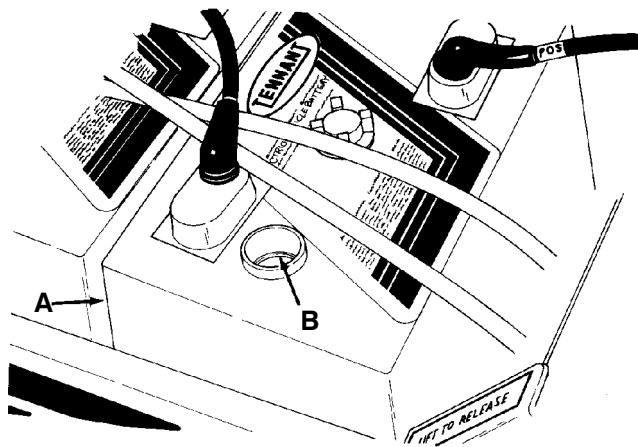

CHECKING BATTERY ELECTROLYTE LEVEL ⁰⁰⁸⁷⁹

- A. Battery
- B. Electrolyte Indicator Ring

FOR SAFETY: When Servicing Machine, Avoid Contact With Battery Acid.

5. Check the battery specific gravity to determine the state of charge as described in *BATTERIES* in the *MAINTENANCE* section. Charge the batteries if necessary.
6. Connect the batteries-to-machine connector.

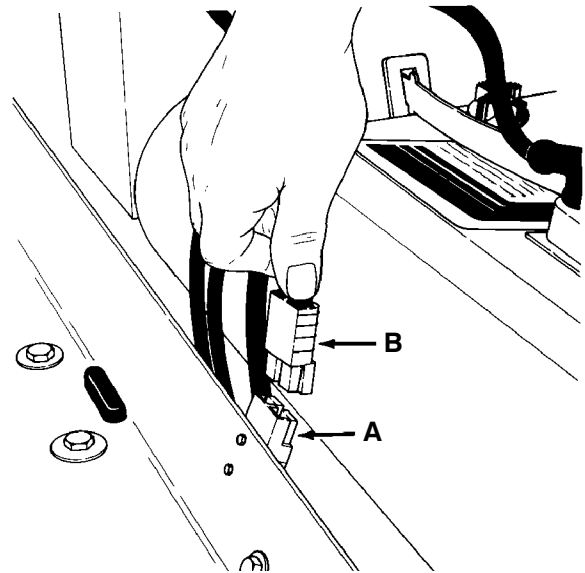

CONNECTING BATTERIES-TO-MACHINE CONNECTOR ⁰³⁰⁶⁵

- A. Machine Connector
- B. Batteries Connector

7. Multi-level dump model machines: Check the hydraulic fluid level in the hydraulic fluid reservoir. See *HYDRAULICS* in the *MAINTENANCE* section.
8. Check the transmission fluid level. See *HYDRAULICS* in the *MAINTENANCE* section.
9. Check the main brush adjustment. See *BRUSHES* in the *MAINTENANCE* section.

OPERATION OF CONTROLS

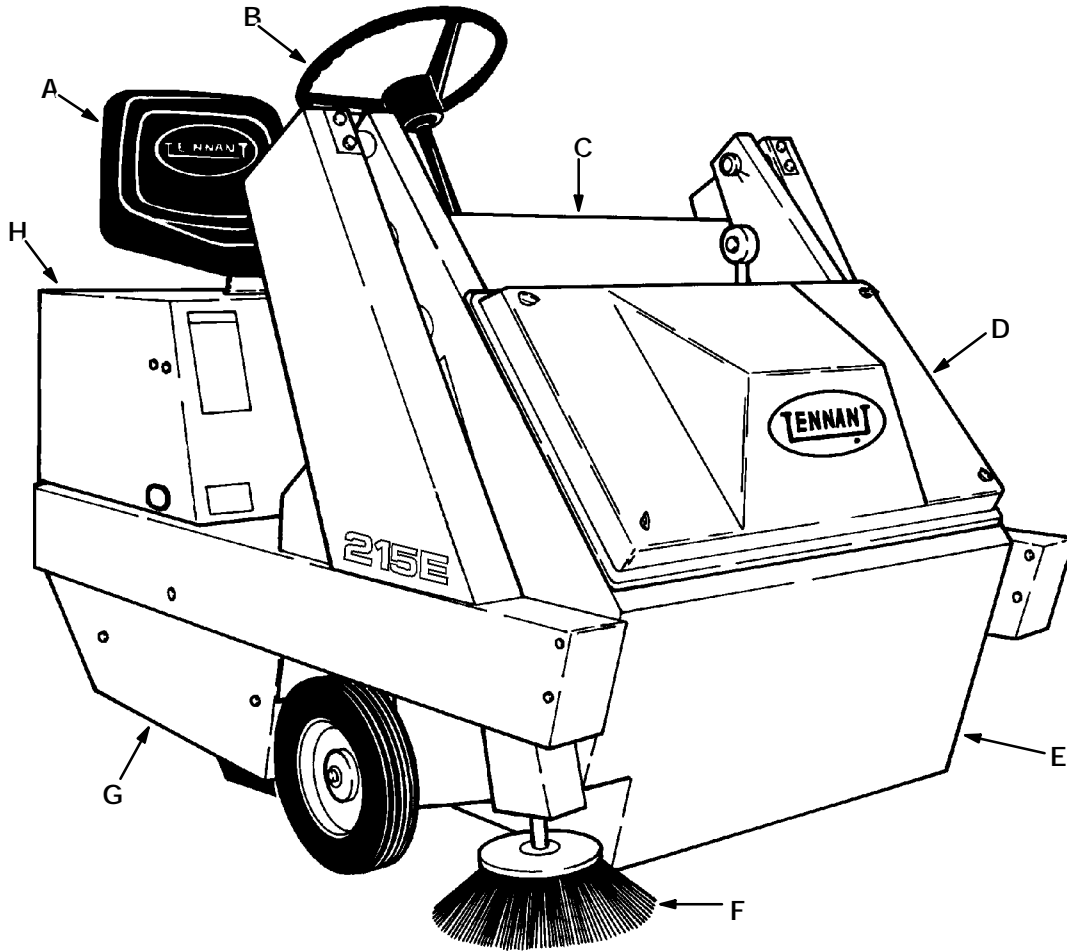

MACHINE COMPONENTS

03085

- | | |
|---------------------|-----------------|
| A. Operator Seat | E. Hopper |
| B. Steering Wheel | F. Side Brush |
| C. Instrument Panel | G. Access Door |
| D. Filter Cover | H. Seat Support |

INSTRUMENT PANEL SYMBOLS

These symbols are used to identify controls and displays on the machine:



Side Brush Down



Side Brush Up



Main Brush Down



Main Brush Up



Main Brush Extra Down Pressure



Hopper Door Close



Hopper Door Open



Hopper Up



Hopper Down



Filter Shaker



Start



Hazard Light



Operational Lights



Key Switch



Horn



Interrupt Switch



Battery Charger Interrupt



Battery Charger



Battery

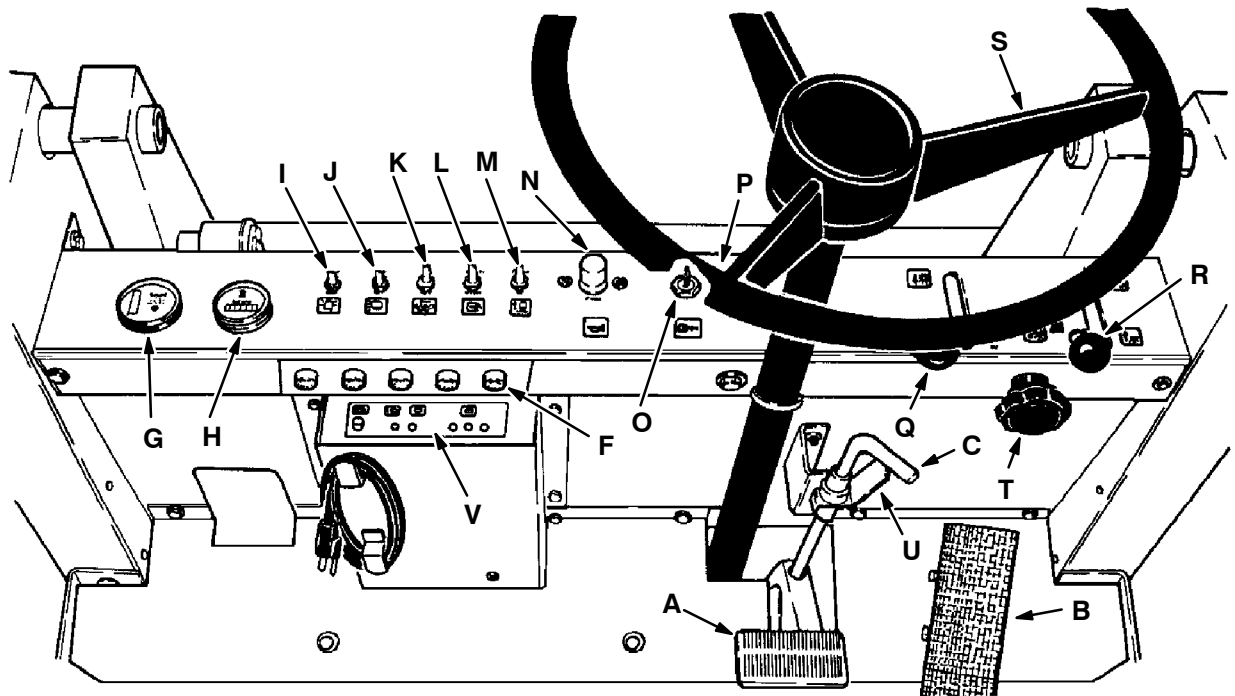

(For machines serial number 003860 and above)

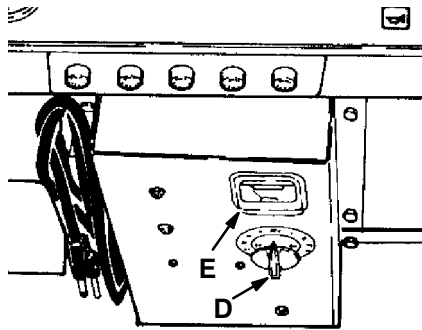

(For machines serial number 000000 to 003859)

CONTROLS AND INSTRUMENTS

03086

- | | |
|--|--------------------------------|
| A. Brake Pedal | L. Hopper Door Switch |
| B. Directional Pedal | M. Hopper Switch |
| C. Parking Brake Lever | N. Horn Button |
| D. Charger Timer | O. Key-Operated On-off Switch |
| E. Charger Gauge | P. Start Switch |
| F. Circuit Breakers | Q. Main Brush Lever |
| G. Battery Discharge Indicator/
Voltmeter | R. Side Brush Lever |
| H. Hour Meter | S. Steering Wheel |
| I. Hazard Light Switch | T. Main Brush Adjustment Knob |
| J. Lights Switch | U. Parking Brake Release Lever |
| K. Filter Shaker Switch | V. Charger Panel |

BRAKE PEDAL

The brake pedal operates the mechanical disc brakes on the two front wheels.

To stop the machine, return the direction control pedal to neutral, then apply pressure to the brake pedal.

DIRECTIONAL PEDAL

The directional pedal controls the propelling drive. It is used to select the direction of travel and the speed of the machine.

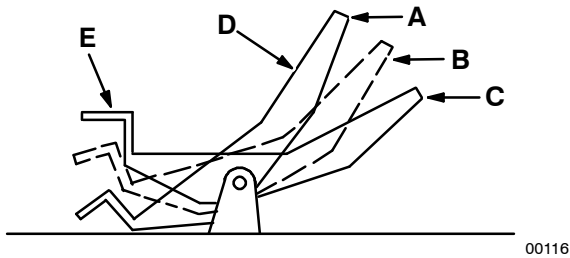

DIRECTIONAL PEDAL

00116

- A. "Reverse" Position
- B. "Neutral" Position
- C. "Forward" Position
- D. "Toe" Portion
- E. "Heel" Portion

Gradually press the "toe" portion of the pedal for forward travel or the "heel" portion for reverse travel. Regulate the machine speed by varying the pressure on the control pedal.

If the machine creeps when the pedal is in the "neutral" position, adjust the directional control pedal.

NOTE: Always use the brake pedal for normal stopping and controlling speed on down grades.

PARKING BRAKE LEVER

The parking brake lever operates the front wheel disc brakes. To set the parking brake, pull the handle up. To release the parking brake, pull the release lever. Always park on a level surface, stop the engine, and set the parking brake before leaving the machine unattended and before working on the machine.

FOR SAFETY: Before Leaving Or Servicing Machine; Stop On Level Surface, Set Parking Brake, Turn Off The Machine And Remove Key.

CHARGER TIMER

The charger timer controls the battery charger on machines below serial number 003860. To start the battery charger, turn the timer knob to the number of hours you wish to charge the batteries. The timer will automatically stop the charger.

CHARGER GAUGE

The charger gauge indicates the level of charge being passed to the batteries on machines below serial number 003860. The gauge needle should be in the green area when charging and in the black area when done.

BATTERY DISCHARGE INDICATOR

The battery discharge indicator is an option on machines below serial number 003860. It indicates the present state of charge of the batteries. The display should be on the F mark of the gauge when the batteries are fully charged. As the batteries discharge, the display will move down near the E mark. The batteries should be recharged when the display gets to the 1/4 mark.

VOLTMETER

The voltmeter indicates the present state of battery charge on machines serial number 003860 and above. The needle should be in the *white* zone when the batteries are fully charged. As the batteries discharge, the needle will move into the *green* zone. Recharge the batteries when the needle consistently stays in the *red* zone.

NOTE: Do not charge the batteries more often than is necessary. This will prolong the life of the batteries. Do not allow the batteries to become fully discharged as this will also damage the batteries. See BATTERIES in the MAINTENANCE section.

HOURLY METER

The hour meter records the number of hours the machine has operated. This information is useful in determining when to service the machine.

HAZARD LIGHT SWITCH

The hazard light switch is present on machines with the flashing or revolving light accessory. To operate the hazard light, move the switch to the top position. To stop the light, move the switch to the bottom position.

OPERATION

LIGHTS SWITCH

The lights switch is present on machines with the headlight and taillight accessory. To operate the lights, move the switch to the top position. To stop the lights, move the switch to the bottom position.

FILTER SHAKER SWITCH

The filter shaker switch operates the dust filter shaker motor. The shaker motor shakes the dust out of the dust filter. To shake the filter, move the switch to the top position for 15 seconds; then move the switch to the bottom position to stop the filter shaker.

HOPPER DOOR SWITCH

The hopper door switch controls the hopper door position. The hopper door should always be open except when high dumping the hopper. To high dump the hopper, move the hopper door switch to the top position to close the hopper door, raise the hopper with the hopper switch, then move the hopper door switch to the bottom (Hopper Door Open) position to open the hopper door to empty the hopper. After the hopper has emptied, move the hopper switch to the top (Hopper Down) position until the hopper has lowered.

HOPPER SWITCH

The hopper switch controls the hopper position. To dump the hopper, move the switch to the bottom (Hopper Up) position. After the hopper has emptied, move the switch to the top (Hopper Down) position until the hopper has lowered.

HORN BUTTON

The horn button operates the machine horn. It is located on the instrument panel.

KEY-OPERATED ON-OFF SWITCH

The key-operated on-off switch has two positions. To allow the machine to operate, turn the key clockwise. To stop the motor, turn the key counterclockwise.

START SWITCH

The start switch controls the motor starter windings. To start the motor, turn the key clockwise and push the start switch.

MAIN BRUSH POSITION LEVER

The main brush position lever controls the position of the main brush. To raise the main brush, pull the lever back into the (Main Brush Up) position. To lower the main brush, pull the lever back and release it into the (Main Brush Down) position.

When parking the machine, always raise the brush to prevent the bristles from taking a set.

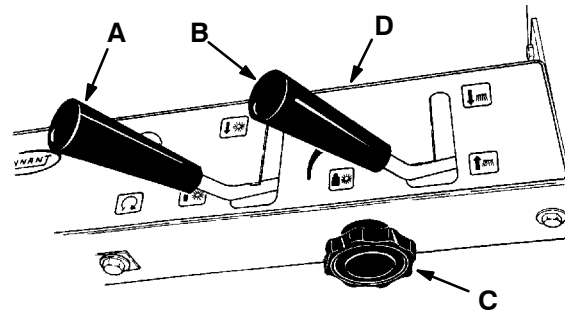

BRUSH CONTROLS

03064

- A. Main Brush Lever**
- B. Side Brush Lever**
- C. Main Brush Height Adjustment Knob**
- D. Instrument Panel**

SIDE BRUSH POSITION LEVER

The side brush position lever controls the position and the drive of the side brush. To raise the side brush, pull the lift lever back into the (Side Brush Up) position. To lower the brush, pull the lever back and release it into the (Side Brush Down) position.

When parking the machine, always raise the brush to prevent the bristles from taking a set.

STEERING WHEEL

The steering wheel controls the rear caster wheel. The machine is very responsive to the movement of the steering wheel. The operator should use care until he or she becomes experienced in guiding the machine.

MAIN BRUSH HEIGHT ADJUSTMENT KNOB

The main brush height adjustment knob (Main Brush Extra Down Pressure) adjusts the main brush contact with the floor. To increase main brush contact with the floor, turn the knob clockwise. To decrease main brush contact with the floor, turn the knob counterclockwise.

CHARGER PANEL

The charger panel indicates battery charging status on machines serial number 003860 and above. The panel is located below the instrument panel. The panel show the status of charging after the charger has been plugged into a wall outlet.

The panel also has an interrupt switch to be used if the charging cycle needs to be stopped.

NOTE: If the charger cycle has to be stopped, press the interrupt switch while unplugging the charger.

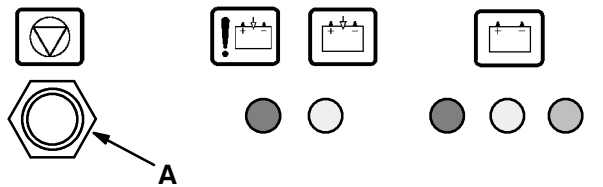

CHARGER PANEL

06898

A. Interrupt Switch

CIRCUIT BREAKERS AND FUSES

Circuit breakers are resettable circuit protection devices designed to stop the flow of current in the event of a circuit overload. Once tripped, circuit breakers must be manually reset. If the overload which caused the circuit breaker to trip is still present in the circuit, the circuit breaker will continue to stop current flow until the overload is corrected.

Fuses are a one-time circuit protection device designed to stop the flow of current in the event of a circuit overload. Never substitute higher value fuses than those specified in this manual.

The circuit breakers are located on the instrument panel. The fuse is located on the fan support bracket.

The following chart shows the various circuit breakers and fuses, and the electrical components they protect.

PROTECTIVE DEVICE	RATING	CIRCUIT PROTECTED
CB-1	10 A	Hopper lift solenoid
CB-2	10 A	Hopper Lift, Hour meter
CB-3	10 A	Horn, Filter Shaker, Voltmeter
CB-4	10 A	Hopper Dump Door
CB-5	10 A	Lights
CB-6	70 A	Electric motor
FU-1	120 A	Hydraulic Pump Motor – Multi-level Dump Model

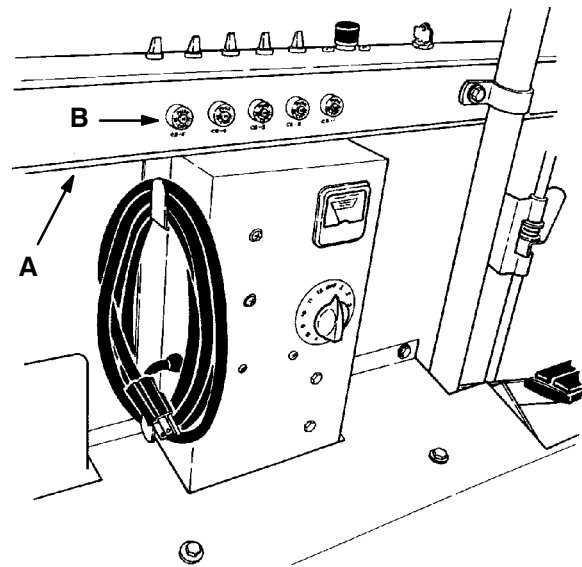

CIRCUIT BREAKERS

03087

**A. Instrument Panel
B. Circuit Breakers**

OPERATION

HOPPER SUPPORT BAR

The hopper support bar is located on the left side of the hopper. It holds the hopper in a “raised” position to allow work to be done under the hopper. Do not rely on the machine hydraulic system to keep the hopper raised.



WARNING: Raised Hopper May Fall. Engage Hopper Support Bar.

TO ENGAGE HOPPER SUPPORT BAR

1. Stop the machine and set the machine parking brake.

FOR SAFETY: Before Leaving Or Servicing The Machine; Stop On Level Surface, Set Parking Brake.

2. Raise the hopper to the “fully raised” position.
3. Position the hopper support bar on the lintel.

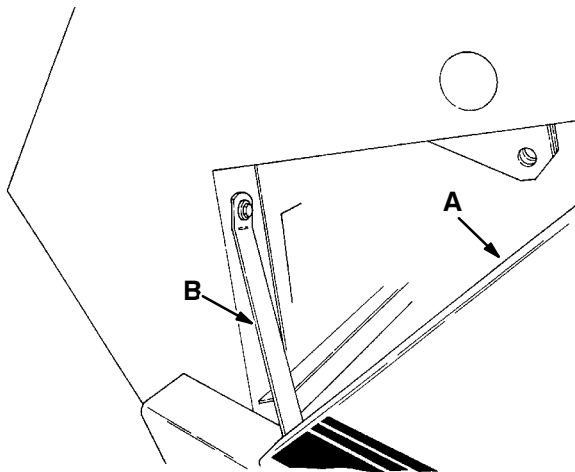

03068
ENGAGED HOPPER SUPPORT BAR - LOW DUMP MODEL

- A. Lintel
- B. Support Bar

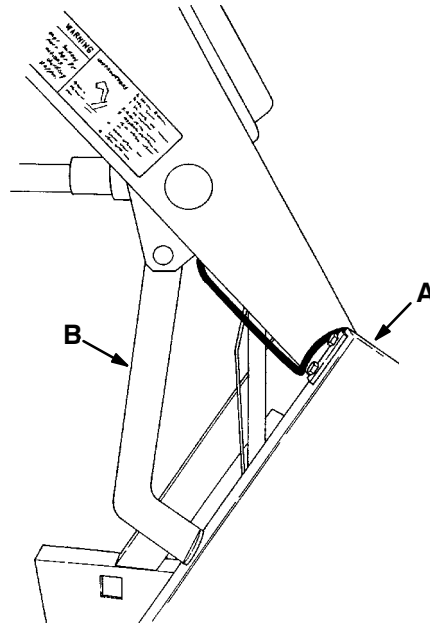

03069
ENGAGED HOPPER SUPPORT BAR - MULTI-LEVEL DUMP MODEL

- A. Lintel
- B. Support Bar

4. Slowly lower the hopper so the bar rests on the lintel.

TO DISENGAGE HOPPER SUPPORT BAR

1. Raise the hopper.
2. Place the support bar in its storage position.
3. Lower the hopper.

MACHINE OPERATION

NORMAL SWEEPING OPERATION

A normal sweeping operation consists of seven typical operations: pre-start checklist, starting machine, sweeping, dumping hopper, post operation checklist – motor operating, stopping machine, and post operation checklist – motor stopped.

PRE-START CHECKLIST lists things to check before starting the machine.

TO START MACHINE lists the steps required to start the machine.

TO SWEEP lists things to keep in mind before and during the sweeping operation.

TO DUMP HOPPER lists the steps required to dump the hopper.

POST OPERATION CHECKLIST – MOTOR OPERATING lists things to check before stopping the machine motor.

TO STOP MACHINE lists the steps required to stop the machine.

POST OPERATION CHECKLIST – MOTOR STOPPED lists things to check after stopping the machine motor.

PRE-START CHECKLIST

Check under machine for leak spots.

Check brakes and controls for proper operation.

Check service records to determine service requirements.

TO START MACHINE

NOTE: Before starting machine, perform the pre-start checks.

1. The machine operator must be in the operator's seat with the directional control pedal in the "neutral" position and with a foot on the brake pedal or with the parking brake set.

FOR SAFETY: Before Starting Machine, Make Sure All Safety Devices Are In Place And Operate Properly.

2. Turn the key-operated on-off switch to the right.
3. Push the start switch until the motor starts.
4. Release the machine parking brake.
5. Drive the machine to the area to be swept.

TO SWEEP

Plan the sweeping in advance. Try to arrange long runs with minimum stopping and starting. Sweep debris from very narrow aisles into main aisles ahead of time. Do an entire floor or section at one time.

Pick up oversize debris before sweeping. Flatten or remove bulky cartons from aisles before sweeping. Pick up pieces of wire, twine, string, etc., which could become entangled in brush or brush plugs. Overlap brush paths.

Avoid turning the steering wheel too sharply when the machine is in motion. The machine is very responsive to the movement of the steering wheel. Avoid sudden turns, except in emergencies.

Sweep as straight a path as possible. Avoid bumping into posts or scraping the sides of the sweeper.

1. Move the main brush position lever into the (Main Brush Down) position.
2. Move the side brush position lever into the (Side Brush Down) position.
3. Sweep as required.

OPERATION

TO DUMP HOPPER

1. Pull the main brush position lever back into the (Main Brush Up) position.
2. Pull the side brush position lever back into the (Side Brush Up) position.
3. Move the filter shaker switch to the top position for 10 to 15 seconds to shake the dust filter.
4. Slowly drive the machine up to the dump site or dumpster.
5. Low dump model machines: Move the hopper dump switch to the bottom (Hopper Up) position to dump the hopper.

Multi-level dump model machines: Move the hopper door switch to the top (Hopper Door Close) position; move the hopper dump switch to the bottom (Hopper Up) position; then move the hopper door switch to the bottom (Hopper Door Close) position to dump the hopper.

6. Move the hopper switch to the top (Hopper Down) position to lower the hopper.
7. Slowly back the machine away from the dump site or dumpster.

POST OPERATION CHECKLIST - MOTOR OPERATING

Check brush patterns for width and evenness.

NOTE: Before leaving the machine, perform the post operation checks.

TO STOP MACHINE

1. Return the directional pedal to the "neutral" position. Apply the brake.
2. Pull the main brush position lever into the (Main Brush Up) position.
3. Pull the side brush position lever into the (Side Brush Up) position.
4. Set the machine parking brake.

5. Turn the key-operated on-off switch to the left. Remove the key from the switch.

FOR SAFETY: Before Leaving Or Servicing The Machine; Stop On Level Surface, Set Parking Brake.

POST OPERATION CHECKLIST - MOTOR STOPPED

Check skirts for damage, wear, and adjustment.

Check for wire or string tangled on brushes.

Check for leaks.

OPERATION ON GRADES

Drive the machine slowly on grades. Use the brake pedal to control machine speed.

FOR SAFETY: When Using Machine, Go Slow On Grades And Slippery Surfaces.

The maximum rated climb and descent angle is 8°.

MACHINE TROUBLESHOOTING

Problem	Cause	Remedy
Excessive Dusting	Dust skirts and seals worn, damaged, not adjusted properly	Replace or adjust skirts or seals
	Dust filter clogged	Shake and/or clean or replace filter
	Vacuum hose damaged	Replace vacuum hose
	Vacuum fan failure	Belt broken or off sheave
Poor sweeping performance	Brush bristles worn	Replace brushes
	Brushes not adjusted properly	Adjust brushes
	Debris caught in brush drive mechanism	Free mechanism of debris
	Main brush drive failure	Belt broken or off sheave
	Side brush drive failure	Belt broken or off sheave
	Hopper not adjusted properly	Adjust hopper floor clearance
	Hopper full	Empty hopper
	Hopper floor skirts worn, damaged	Replace skirts
Machine will not travel	Directional control pedal linkage out of adjustment or broken	Check adjustment or damage
	Transmission drive belt slipping or broken	Check belt
	Transmission malfunction	Repair or replace Transmission
	Wheel drive chains or sprockets broken	Check and replace
	Jackshaft belt broken or slipping	Check and adjust or replace

TRANSPORTING MACHINE

PUSHING OR TOWING MACHINE

The machine may be slowly pushed only from the rear, pushing on the machine frame.

The machine may be slowly towed from the front. Use care when attaching towing cables or chains to avoid damaging the machine.

MACHINE JACKING

The machine may be jacked up for service at the designated locations. Use a jack of adequate capacity and good working condition. Always stop the machine on a flat, level surface and block the tires before jacking the machine up. The front jacking locations are on the flat bottom edge of the machine frame next to the front tires.

The rear jacking location is the middle flat bottom edge of the rear bumper.

TO JACK UP MACHINE

1. Empty the debris hopper.
2. Stop the motor and set the machine parking brake.

FOR SAFETY: Before Leaving Or Servicing The Machine; Stop On Level Surface, Set Parking Brake.

3. Block the tires, which are not being jacked up, in order to secure the machine position.

FOR SAFETY: When Servicing Machine, Block Machine Tires Before Jacking Machine Up.

4. Use a jack of adequate capacity to raise the machine. Jack up the machine only at the designated locations.

FOR SAFETY: When Servicing Machine, Jack Machine Up At Designated Locations Only. Block Machine Up With Jack Stands.

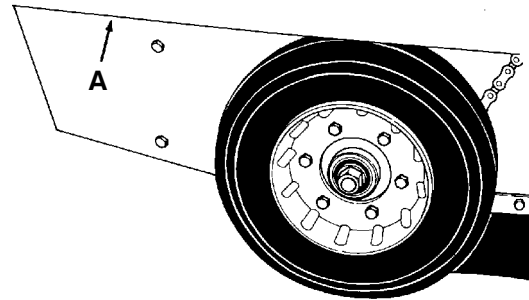

03070

FRONT JACKING LOCATION

A. Jacking Location

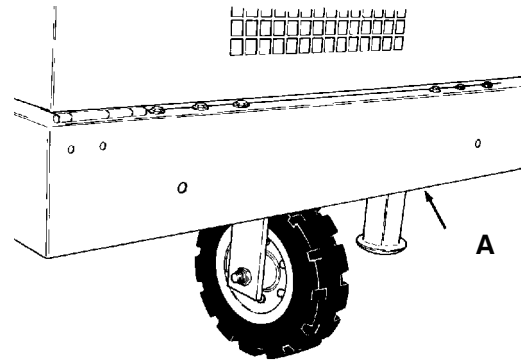

03071

REAR JACKING LOCATION

A. Jacking Location

5. Block machine up with jack stands or similar devices in the designated locations to secure the machine.
6. Lower the machine onto the jack stands.
7. Check to make sure the machine is secure.
8. Service the machine as required.
9. When finished servicing the machine, raise the machine off the jack stands.
10. Remove the jack stands from under the machine.
11. Lower the machine.
12. Remove the blocks from the tires.

MACHINE TIE-DOWNS

The machine may be tied down at each of the corners of the main frame at the locations specified.

To tie the machine down, use the holes on the front and the lower rear machine frame.

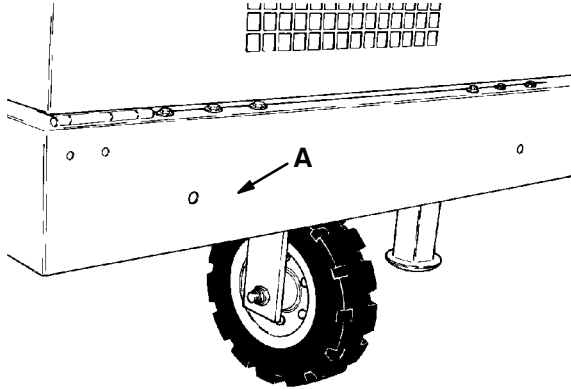

REAR TIE-DOWN LOCATION

03071

A. Tie-Down Hole

When transporting the machine on a trailer or in a truck, be sure to engage the machine parking brake and block the machine tires to prevent the machine from rolling.

MACHINE STORAGE

STORING MACHINE

When storing the machine for extended periods of time, the following procedures must be followed to lessen the chance of rust, sludge, or other undesirable deposits from forming.

1. Empty debris hopper.
2. Place the main brush and side brush levers in the raised position.
3. Fully charge the batteries.
4. Disconnect the batteries-to-machine connector.
5. Park the machine in a cool, dry area.

SECTION 3

CONTENTS

	Page		Page
RECOMMENDED FIRST 20-HOUR		DEBRIS HOPPER AND DUST FILTER ...	3-23
MACHINE INSPECTION	3-3	DEBRIS HOPPER	3-23
MAINTENANCE CHART	3-4	TO CHECK AND ADJUST HOPPER	
LUBRICATION	3-6	FLOOR CLEARANCE	3-23
TRANSMISSION	3-6	HOPPER DUST FILTER	3-23
DIFFERENTIAL	3-6	TO REMOVE AND REPLACE HOPPER	
DRIVE CHAINS	3-6	DUST FILTER	3-24
STEERING GEAR	3-7	SKIRTS AND SEALS	3-25
LIFT CYLINDER	3-7	BRUSH SKIRTS	3-25
HYDRAULICS	3-8	TO ADJUST BRUSH SKIRTS	3-25
HYDRAULIC FLUID	3-8	TO REPLACE BRUSH SKIRTS	3-25
HYDRAULIC FLUID RESERVOIR	3-8	HOPPER SEALS	3-26
HYDRAULIC SCHEMATIC	3-9	TO REPLACE HOPPER SEALS	3-26
ELECTRICAL SYSTEM	3-10	HOPPER DUMP DOOR SEAL	3-26
BATTERIES	3-10	TO REPLACE HOPPER DUMP	
BATTERY CHARGING	3-11	DOOR SEAL	3-26
TO CHARGE BATTERIES (For machines		REAR SKIRTS	3-27
below serial number 003860)	3-11	TO REPLACE AND ADJUST	
TO CHARGE BATTERIES (For		REAR SKIRTS	3-27
machines serial number 003860		HOPPER LIP SKIRT	3-27
and above)	3-12	TO REPLACE HOPPER LIP SKIRT .	3-27
ACTIVATING DRY-TYPE BATTERIES .	3-13	BRUSHES	3-28
TO ACTIVATE DRY-TYPE		MAIN BRUSH	3-28
BATTERIES	3-13	TO REMOVE MAIN BRUSH	3-28
ELECTRIC MOTOR	3-13	TO INSTALL MAIN BRUSH	3-28
ELECTRICAL SCHEMATIC (For machines		TO CHECK AND ADJUST MAIN	
below serial number 003860)	3-14	BRUSH PATTERN	3-29
ELECTRICAL SCHEMATIC (For machines		SIDE BRUSH	3-30
serial number 003860 and above)	3-15	TO REMOVE SIDE BRUSH	3-30
ELECTRICAL SCHEMATIC (For machines		TO INSTALL SIDE BRUSH	3-30
serial number 003860 and above)	3-16	TRANSMISSION	3-31
BELTS AND CHAINS	3-17	TRANSMISSION	3-31
VACUUM FAN BELT	3-17	TRANSMISSION LINKAGE	3-32
TO REPLACE VACUUM FAN BELT .	3-17	BRAKES AND TIRES	3-33
TRANSMISSION BELT	3-17	BRAKES	3-33
TO REPLACE TRANSMISSION BELT	3-17	TIRES	3-33
JACKSHAFT BELT	3-18		
TO REPLACE JACKSHAFT BELT ..	3-18		
INTERMEDIATE SIDE BRUSH BELT ..	3-18		
TO REPLACE INTERMEDIATE SIDE			
BRUSH BELT	3-18		
SIDE BRUSH BELT	3-19		
TO REPLACE SIDE BRUSH BELT .	3-19		
MAIN BRUSH BELT	3-19		
TO REPLACE MAIN BRUSH BELT .	3-19		
DRIVE CHAIN AND BELT ALIGNMENT AND			
TENSIONING	3-20		
TO ALIGN AND TENSION DRIVE CHAINS			
AND BELTS	3-20		
STATIC DRAG CHAIN	3-22		

RECOMMENDED FIRST 20-HOUR MACHINE INSPECTION

After the first 20 hours of operation, the following procedures are recommended:

1. Check the brush pattern for correct brush adjustment.
2. Check the floor skirts to floor clearance.
3. Check the side brush and main brush patterns.

MAINTENANCE CHART

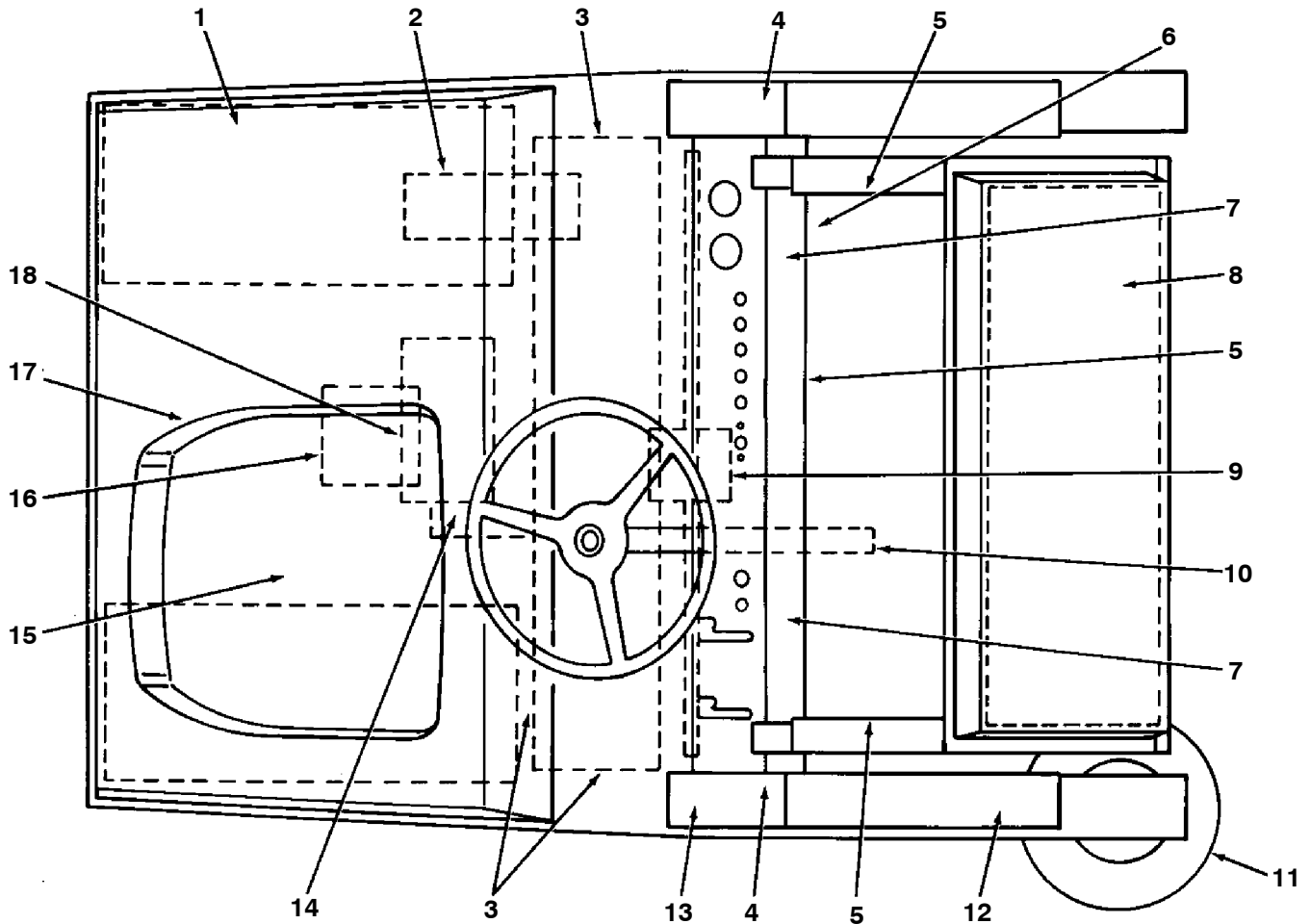

03088

Interval	Key	Description	Procedure	Lubricant/ Fluid	No. of Service Points
Daily	15	Seat switch	Check for proper operation		1
	8	Dust filter	Shake	-	1
	3	Brush skirts	Check for damage and wear	-	3
	13	Main brush	Check for damage and wear	-	1
			Check floor pattern	-	1
	11	Side brush	Check for damage and wear	-	1
			Check floor pattern	-	1
5	Hopper	Check for hopper door seal for damage and wear	-	3	
25 Hours	1	Batteries	Check electrolyte level	DW	6
	16	Transmission	Check oil level	EO	1
	2	Hydraulic reservoir	Check fluid level	HYDO	1

Interval	Key	Description	Procedure	Lubricant/ Fluid	No. of Service Points
50 Hours	1	Batteries	Check specific gravity		6
			Check cable connections		12
	12	Intermediate side brush belt	Check tension and wear	-	1
	16	Transmission belt	Check tension and wear	-	1
	17	Vacuum fan belt	Check tension and wear	-	1
	13	Main brush belt	Check for wear	-	1
	12	Side brush belt	Check for wear	-	2
	14	Jackshaft belt	Check tension and wear	-	2
		13	Main Brush	Rotate end-for-end	-
	8	Dust filter	Clean or replace	-	1
100 Hours	1	Batteries	Clean tops and terminals	-	6
	4	Drive chains	Check and adjust tension	-	3
			Lubricate	EO	3
	7	Brakes	Adjust	-	2
	9	Differential	Apply grease to fittings	SPL	2
	10	Steering gear	Apply grease to fitting	SPL	1
	5	Hopper	Clean inside	-	1
			Check floor clearance	-	1
	6	Lift cylinder	Apply grease to fitting	SPL	1
400 Hours	18	Motor	Check brushes		2

EO - Engine oil

DW - Distilled water

HYDO - Tennant Company or approved hydraulic fluid

SPL - Special lubricant, Lubriplate EMB grease (TENNANT part No. 01433-1)

NOTE: More frequent intervals may be required in extremely dusty conditions.

LUBRICATION

TRANSMISSION

The transmission drives the two front wheels. Check the oil level after every 25 hours of operation by looking at the reservoir mounted on top of the transmission. The cold oil level should be 0 to 0.25 in (0 to 5 mm) above the cold mark. Use straight SAE 20-weight, API class SF engine oil.

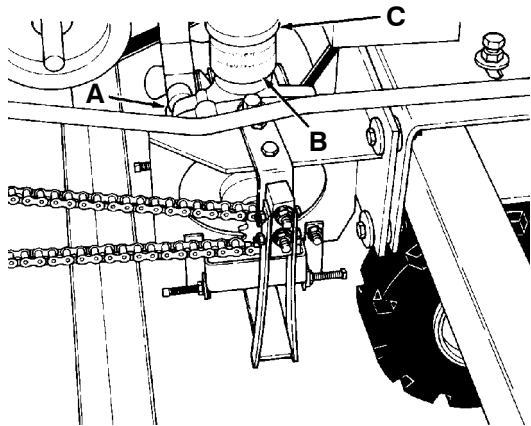

01784

TRANSMISSION

- A. Transmission
- B. Oil Reservoir
- C. Fill Cap

DIFFERENTIAL

The differential drives the two front wheels. Two grease fittings are located on the differential housing for lubrication. The differential should be lubricated by applying Lubriplate EMB grease TENNANT Part No. 01433-1 to the grease fittings after every 100 hours of operation.

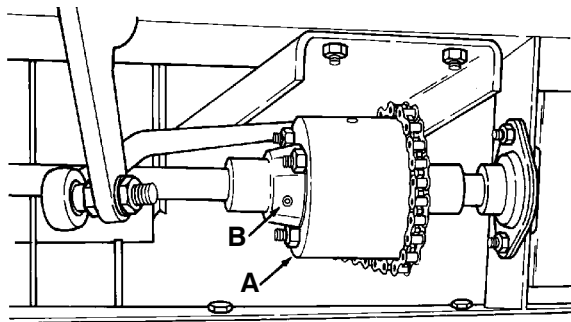

01783

DIFFERENTIAL

- A. Differential
- B. Grease Fitting

DRIVE CHAINS

The two wheel drive chains and the transmission drive chain propel the machine. They should be lubricated with SAE 30-weight engine oil after every 100 hours of operation.

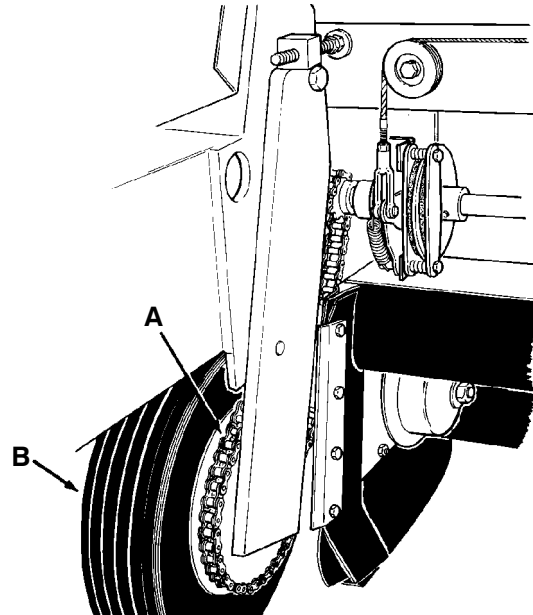

03073

WHEEL DRIVE CHAIN

- A. Drive Chain
- B. Right Tire

STEERING GEAR

The steering gear controls machine steering. A grease fitting is located on the differential housing for lubrication. The steering gear should be lubricated by applying Lubriplate EMB grease TENNANT Part No. 01433-1 to the grease fitting after every 100 hours of operation.

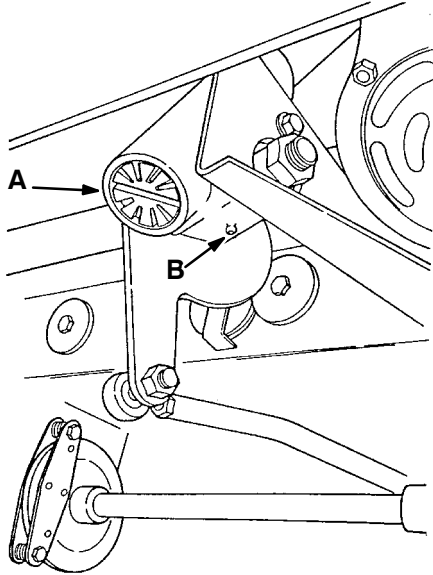
**STEERING GEAR**

01786

- A. Steering Gear**
- B. Grease Fitting**

LIFT CYLINDER

The lift cylinder is present on multi-level dump model machines. It raises the hopper to dump it. The top lift cylinder bearing should be lubricated by applying Lubriplate EMB grease TENNANT Part No. 01433-1 to the grease fitting after every 100 hours of operation.

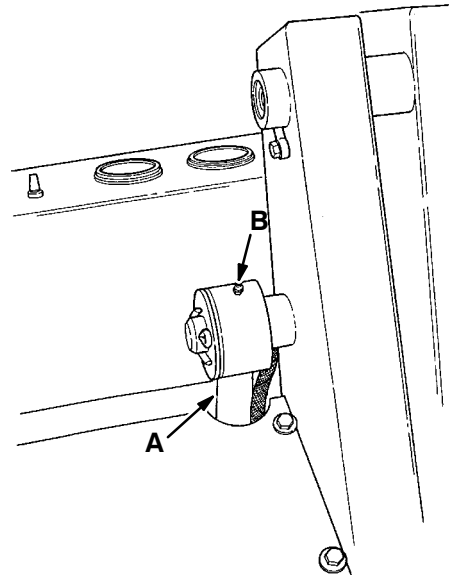
**LIFT CYLINDER**

03091

- A. Lift Cylinder**
- B. Grease Fitting**

HYDRAULICS

HYDRAULIC FLUID

Hydraulic fluid is used in some components of multi-level dump model machines. The quality and condition of the hydraulic fluid plays a very important role in how well they operate. Tennant Company has developed its own hydraulic fluid to meet the special needs of its machines.

TENNANT Hydraulic Fluid is a specially compounded oil with the following features not found in many hydraulic fluids:

1. Flat viscosity curve.
2. Additives to prevent corrosion.
3. Additives to prevent oxidation.
4. Rust inhibitors.
5. Foam suppressers.

These features restrict foaming of the hydraulic fluid and provide a high standard of lubrication to the components.

TENNANT HYDRAULIC FLUID VISCOSITY SPECIFICATIONS

	TENNANT Hyd. Fluid No. 65870 (HP0520)
SUS @ 100° F (38° C)	150-200
SUS @ 210° F (99° C)	46 Min.

TENNANT Hydraulic Fluids have a very flat viscosity curve (synonymous with “high viscosity index”). The flat viscosity curve means that the thickness of the fluid is very constant over wide temperature ranges.

If a locally-available hydraulic fluid is preferred, or if products of only one oil company are used, the hydraulic fluid used must match closely the viscosity specifications given in the chart for TENNANT Hydraulic Fluid, as well as the other features described. Do not substitute automatic transmission fluid for hydraulic fluid.

ATTENTION! Hydraulic components depend on system hydraulic fluid for internal lubrication. If dirt or other contaminants are allowed to enter the hydraulic system, malfunctions, accelerated wear, and damage will result.

HYDRAULIC FLUID RESERVOIR

Hydraulic fluid is stored in the hydraulic fluid reservoir. It holds 2 qt (1.8 L) of hydraulic fluid. The reservoir is mounted on the back of the hydraulic pump.

A dipstick has been provided to check hydraulic fluid level. The reservoir is full when the fluid level is between the two holes in the dipstick.

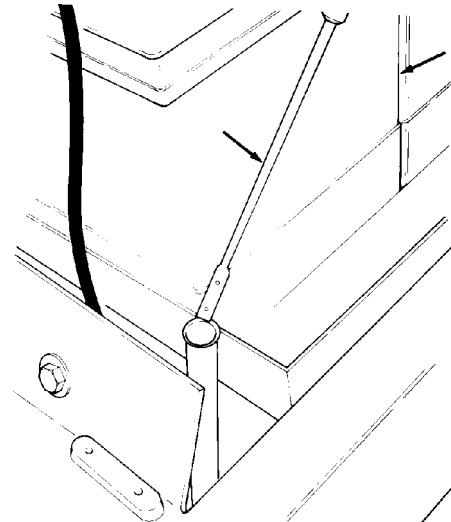

HYDRAULIC PUMP

03093

- A. Battery
- B. Dipstick

Check the hydraulic fluid level after every 25 hours of operation with the hopper in the (Hopper Down) position. Do not overfill the hydraulic fluid reservoir. Hydraulic fluid expands as it heats to its normal operating temperature. Always allow for expansion when filling the reservoir.

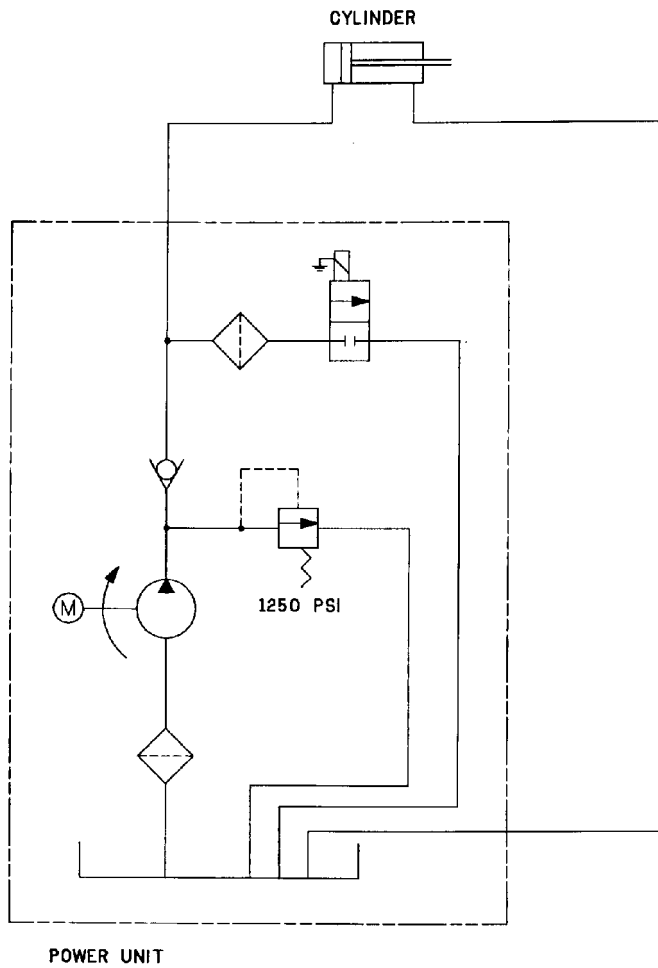

HYDRAULIC SCHEMATIC

03078

ELECTRICAL SYSTEM

BATTERIES

The six 6-volt machine batteries provide all of the energy used by the machine. The standard batteries are rated at 220 A/h at a 20-hour rate. The heavy duty batteries are rated at 305 A/h at a 20-hour rate. The maximum allowable battery weight is 625 lb (285 kg). They require regular maintenance to keep them operating their best.

Do not allow batteries to remain in discharged condition for any length of time.

Do not operate machine if batteries are in poor condition or only 25% of the charge is left.

Periodically check the battery cables for loose connections and corrosion.

Clean the top surface and the terminals of the batteries after every 100 hours of operation. Use a strong solution of baking soda and water. Brush the solution sparingly over the battery top, terminals, and cable clamps. Do not allow any baking soda solution to enter the battery. Use a wire brush to clean the terminal posts and the cable connectors. After cleaning, apply a coating of clear petroleum jelly to the terminals and the cable connectors. Keep the tops of the batteries clean and dry.

Keep all metallic objects off the top of the batteries, as they may cause a short circuit. Replace worn or damaged wires.

Check the electrolyte level in each battery cell after every 25 hours of operation. The electrolyte level must always be above the battery plates. Add distilled water to maintain solution at the correct level above the plates, but do not overfill. Never add acid to batteries, only water. Keep vent plugs firmly in place at all times, except when adding water or taking hydrometer readings.

FOR SAFETY: When Servicing Machine, Avoid Contact With Battery Acid.

Use a hydrometer to check the electrolyte specific gravity.

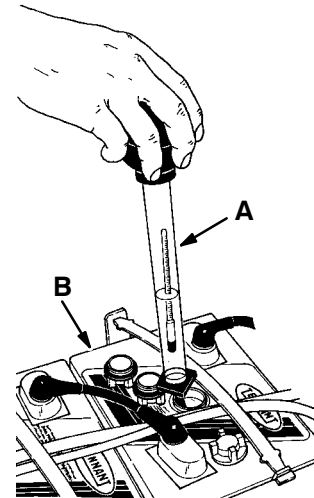

CHECKING BATTERY SPECIFIC GRAVITY

01373

- A. Hydrometer**
- B. Battery**

If one or more battery cells tests lower than the other battery cells, (0.050 or more) the cell is damaged, shorted, or is about to fail.

NOTE: Do not take readings immediately after adding water – if the water and acid are not thoroughly mixed, the readings may not be accurate. Check the hydrometer readings against this chart:

SPECIFIC GRAVITY at 80° F (27° C)	BATTERY CONDITION
1.265	100% charged
1.225	75% charged
1.190	50% charged
1.155	25% charged
1.120	Discharged

NOTE: If the readings are taken when the battery electrolyte is any temperature other than 80° F (27° C), the reading must be temperature corrected.

To determine the corrected specific gravity reading when the temperature of the battery electrolyte is other than 80° F (27° C):

Add to the specific gravity reading 0.004, 4 points, for each 10° F (6° C) above 80° F (27° C).

Subtract from the specific gravity reading 0.004, 4 points, for each 10° F (6° C) below 80° F (27° C).

BATTERY CHARGING

The machine batteries are specially made for this machine application. They are unique in that they hold their power for long periods of time, but they can only be recharged a certain number of times. To get the most life from the batteries, charge them when 25% of their charge is left.

Do not expose the battery charger to water. Do not touch uninsulated battery terminals or unnecessarily expose any portion of your body to the batteries when making electrical connections.

TO CHARGE BATTERIES (For machines below serial number 003860)

Ten to twelve hours is generally enough time to charge a discharged set of standard, 220 A/h batteries. Fourteen to sixteen hours is generally enough time to charge a set of heavy duty, 305 A/h batteries. If the batteries are not fully discharged, set the timer for a period of time that is proportionally less than what is required for a fully discharged set of batteries, ie: half discharged heavy duty batteries need seven to eight hours of charging time.

1. Stop the machine on a flat, dry surface next to an electrical outlet and set the parking brake.
2. Turn the key-operated on-off switch counterclockwise.

FOR SAFETY: Before Leaving Or Servicing Machine; Stop On Level Surface, Set Parking Brake, And Turn Off Machine.

3. Open the seat support.



WARNING: Batteries Emit Hydrogen Gas. Explosion Or Fire Can Result. Keep Sparks And Open Flame Away. Keep Covers Open When Charging.

4. Check the electrolyte level in the batteries. Before charging, add just enough distilled water to cover the plates. Then, after charging is completed, add enough water to bring the electrolyte up to the indicator mark. If the water level is topped off before charging, normal expansion of the electrolyte may cause an overflow, resulting in loss of acid balance and acid damage to the machine area around the batteries.

5. Plug the battery charger cord into a wall outlet.
6. Turn the battery charger knob to the number of hours you wish to charge the batteries. The charger gauge will indicate the charger is operating.

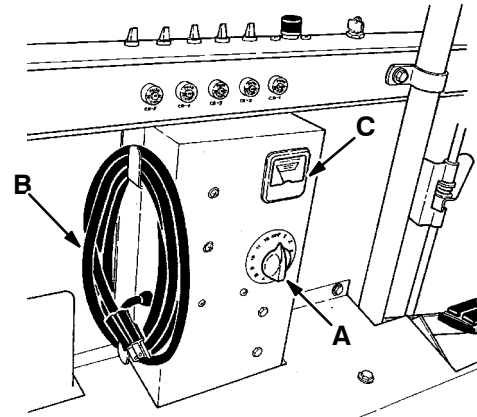

03087

BATTERY CHARGER

- A. Charger Knob**
- B. Power Cord**
- C. Charger Gauge**

7. The batteries will be fully charged when the timer reads "off" or the battery specific gravity is 1.265.
8. Turn the timer to "off" position.
9. Unplug the battery charger from the wall outlet.
10. Check the electrolyte level of the batteries; it should be up to the indicator mark.

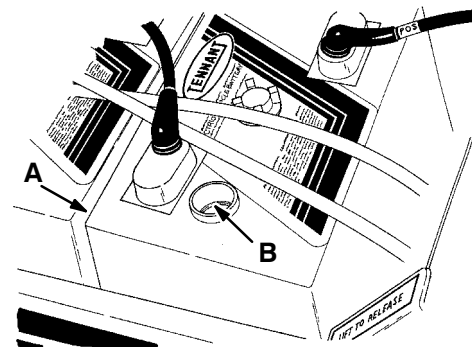

00879

CHECKING BATTERY ELECTROLYTE LEVEL

- A. Battery**
- B. Electrolyte Indicator Ring**

11. Lower the seat support.

MAINTENANCE

TO CHARGE BATTERIES (For machines serial number 003860 and above)

1. Stop the machine on a flat, dry surface next to an electrical outlet and set the parking brake.
2. Turn the key-operated on-off switch counterclockwise.

FOR SAFETY: Before Leaving Or Servicing Machine; Stop On Level Surface, Set Parking Brake, And Turn Off Machine.

3. Open the seat support.



WARNING: Batteries Emit Hydrogen Gas. Explosion Or Fire Can Result. Keep Sparks And Open Flame Away. Keep Covers Open When Charging.

4. Check the electrolyte level in the batteries. Before charging, add just enough distilled water to cover the plates. Then, after charging is completed, add enough water to bring the electrolyte up to the indicator mark. If the water level is topped off before charging, normal expansion of the electrolyte may cause an overflow, resulting in loss of acid balance and acid damage to the machine area around the batteries.
5. Plug the battery charger cord into an AC wall outlet. The charger will go through a self diagnostic check. All the indicator lamps on the charger panel will flash showing the diagnostic check is in progress.

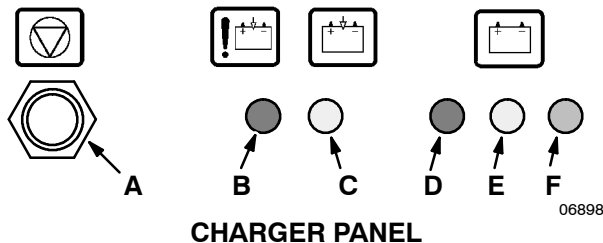

- A. Interrupt Switch
- B. Red No Charge Indicator Lamp
- C. Yellow Charger On Indicator Lamp
- D. Red Incomplete Battery Status Indicator Lamp
- E. Yellow 80% Charge Indicator Lamp
- F. Green Complete Charge Indicator Lamp

NOTE: If the “red no charge indicator lamp” lights when the charger is plugged into a wall outlet, the charger can not charge the battery, meaning there is something wrong with the battery.

When the lamps stop flashing, the “red incomplete battery status indicator lamp” lights. After a short delay, the “yellow charger on indicator lamp” lights showing the charger has turned on.

As the battery charges, the “red incomplete battery status indicator lamp” goes out and the “yellow 80% charge indicator lamp” lights.

Finally the “yellow 80% charge indicator lamp” goes out and the “green complete charge indicator lamp” lights showing the battery is completely charged. After a short time, the “yellow charger on indicator lamp” goes out showing the charger has turned off.

The “green complete charge indicator lamp” will remain on until the charger is unplugged from the wall outlet.

NOTE: If the charge cycle has to be stopped, press the interrupt switch while unplugging the charger from the wall outlet.

6. Unplug the battery charger from the wall outlet.
7. Check the electrolyte level of the batteries; it should be up to the indicator mark.

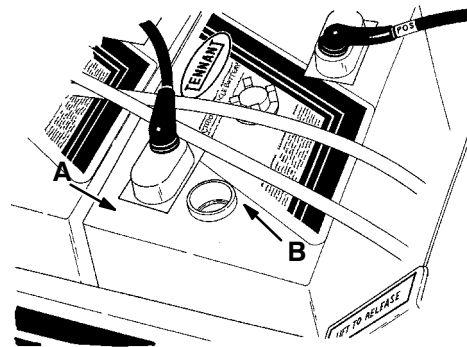

CHECKING BATTERY ELECTROLYTE LEVEL

- A. Battery
- B. Electrolyte Indicator Ring

8. Lower the seat support.

ACTIVATING DRY-TYPE BATTERIES

Some new batteries are supplied in a dry-type form. These batteries need to be activated by filling them with electrolyte before they can be put into service.

TO ACTIVATE DRY-TYPE BATTERIES

1. Extinguish all cigarettes, fire, and spark-producing equipment in the area.



WARNING: Batteries emit hydrogen gas. Explosion or fire can result. Keep flames and sparks away. Keep covers open when charging.

2. Remove the batteries from the shipping crate or the machine and place on a level surface.
3. Remove and save the battery vent caps; or if ventless plugs were provided, remove and discard them.
4. Carefully fill each battery cell with battery grade sulfuric acid to 0.38 in (10 mm) above the battery plates.
5. Check the specific gravity of the batteries. Charge the batteries until the specific gravity is 1.26 to 1.28.

6. Add battery acid if necessary to 0.38 in (10 mm) above the battery plates.
7. Insert battery vent caps in the vent holes.
8. Clean the battery posts and cables.
9. Install the batteries in the machine.
10. Connect the battery cables to the batteries. See the *STANDARD MODEL PARTS* section for correct cable connections.
11. Fill the batteries with water, if necessary, up to the electrolyte indicator rings. Do not add battery acid to the batteries after inserting the vent caps.

ELECTRIC MOTOR

The electric propelling motor is repairable.

Blow out the dust and inspect the motor brushes in the motor after every 400 hours of operation.

If the brushes have been worn to less than 0.38 in (10 mm) in length, replace them.

If the commutator is worn or rough, the motor armature should be removed and serviced.

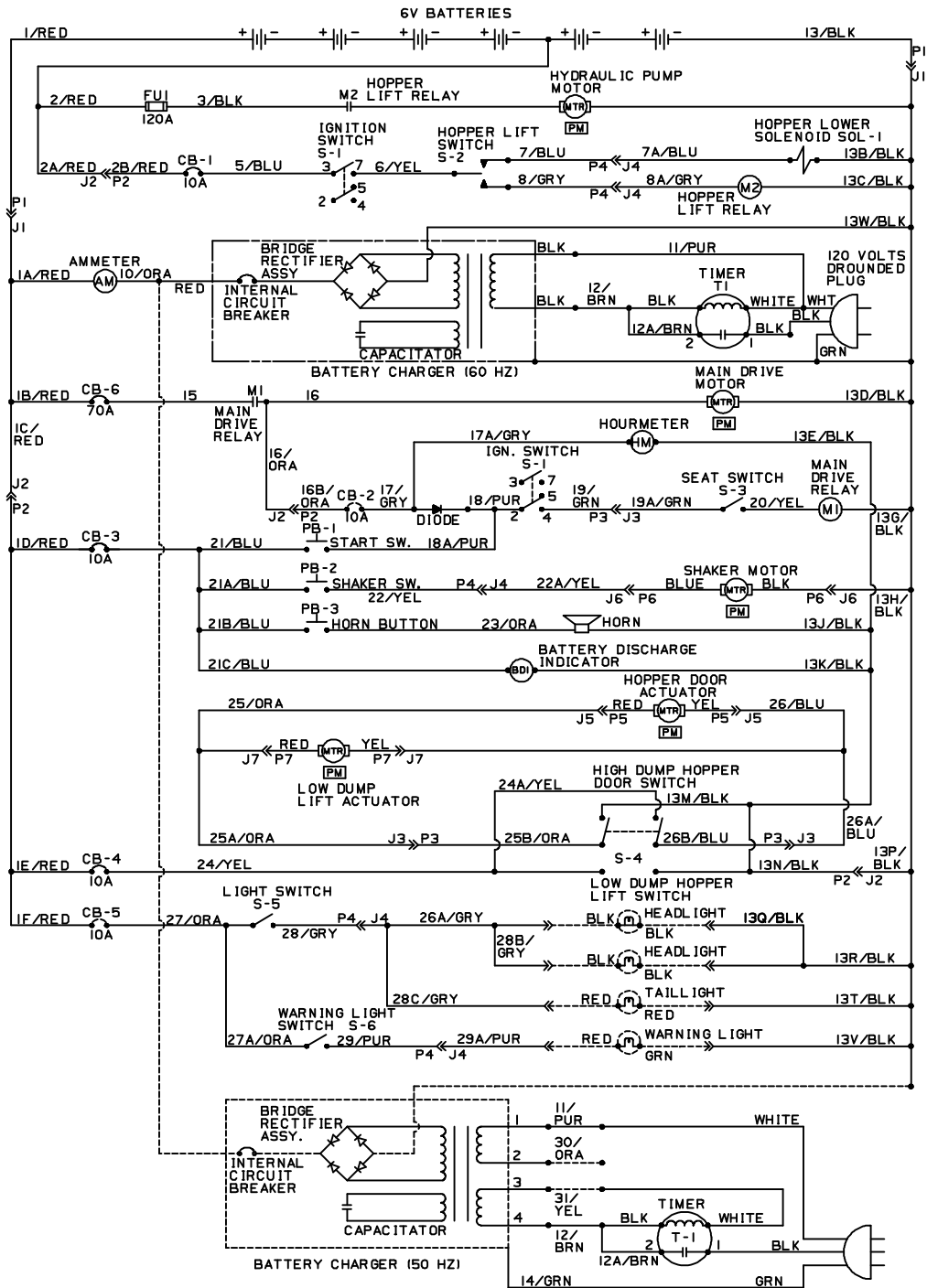

VOLT SUPPLY	CONNECTION	AC LINES ON
112 TO 125	1 TO 3 & 2 TO 4	1 & 4
218 TO 240	2 & 3	1 & 4

M	POWER RELAY	HM	HOURLMETER
MTR	MOTOR	SV	SOLENOID VALVE
CB	CIRCUIT BREAKER	S	SWITCH
PM	PERMANENT MAGNET	ACC	ACCESSORY
J	JACK-FEM. SOCKET	GND	GROUND CHASSIS
P	PLUG-MALE PIN	C	COMMON
PB	PUSHBUTTON	N.O.	NORMALLY OPEN
VM	VOLTMETER	N.C.	NORMALLY CLOSED
FU	FUSE		

ELECTRICAL SCHEMATIC (For machines below serial number 003860)

03089

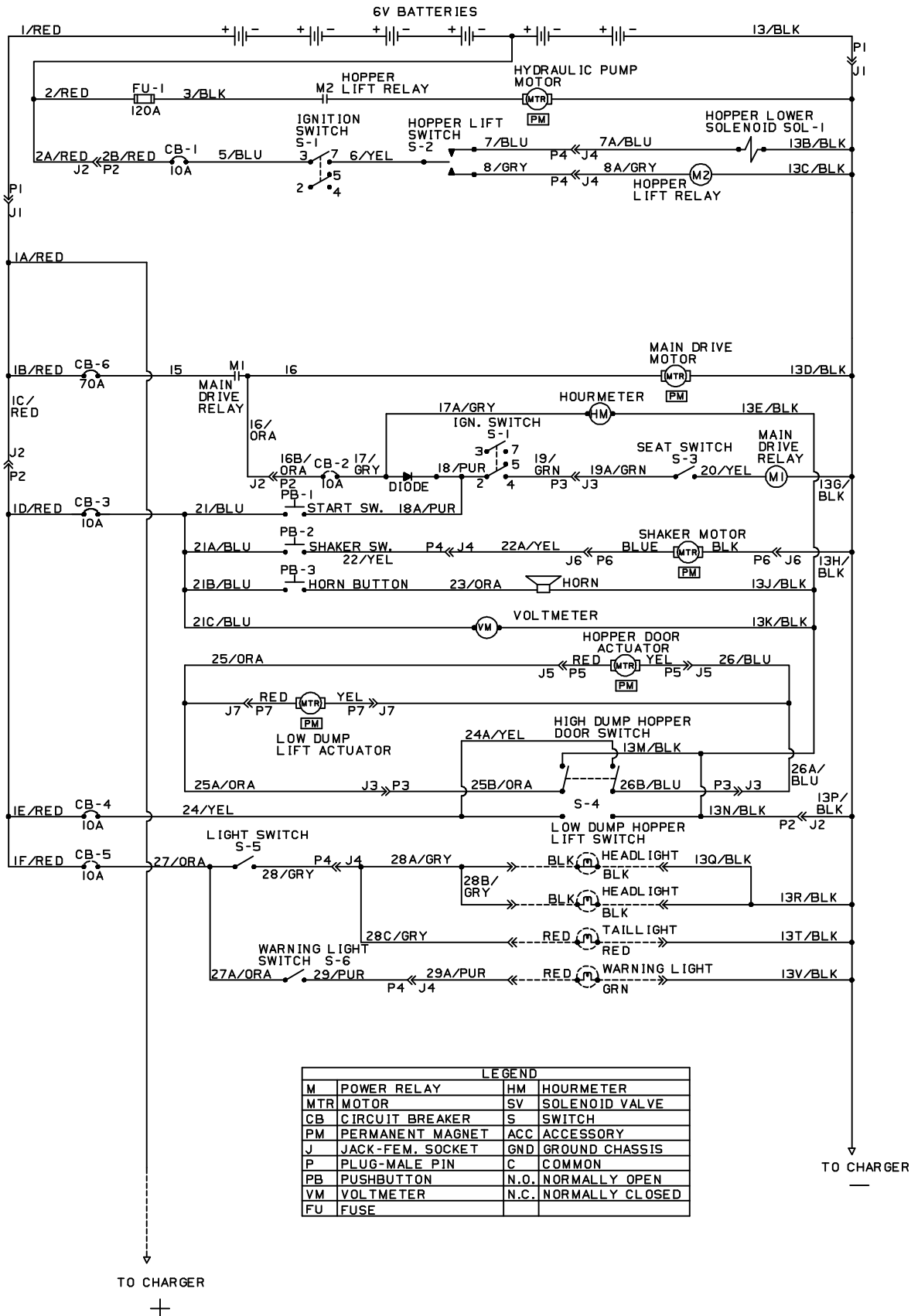

ELECTRICAL SCHEMATIC
(For machines serial number 003860 and above)

03089

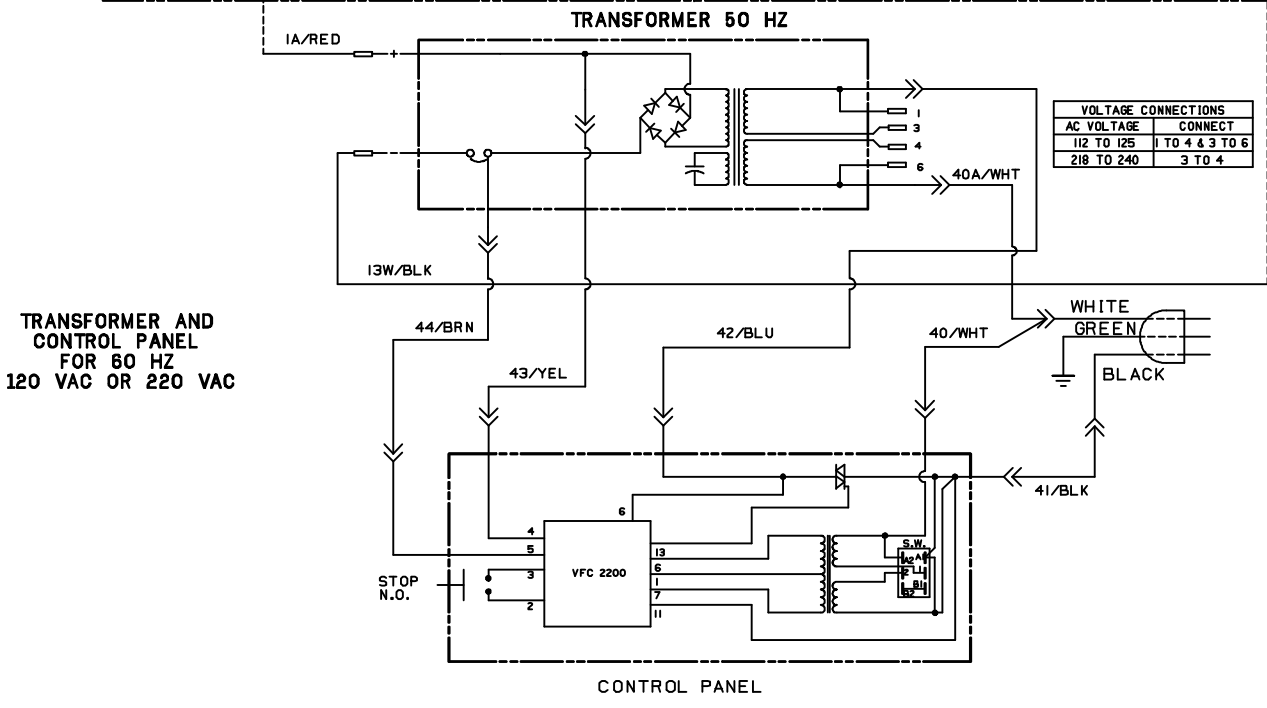
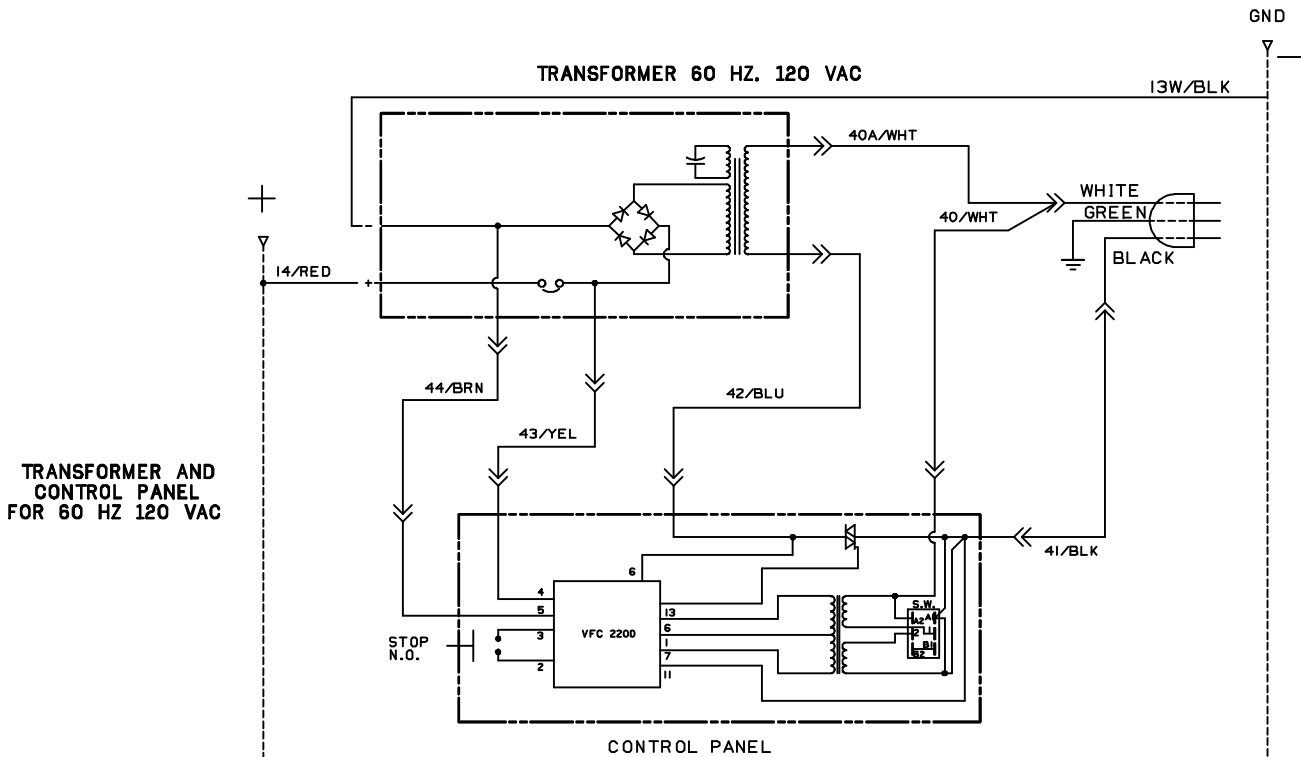

ELECTRICAL SCHEMATIC
(For machines serial number 003860 and above)

03089

BELTS AND CHAINS

VACUUM FAN BELT

The vacuum fan belt transfers power from the motor sheave to the vacuum fan. Check the belt condition and tension after every 50 hours of operation as described in *DRIVE CHAIN AND BELT ALIGNMENT AND TENSIONING*.

TO REPLACE VACUUM FAN BELT

1. Stop the motor and set the parking brake.

FOR SAFETY: Before Leaving Or Servicing Machine; Stop On Level Surface, Set Parking Brake, And Turn Off Machine.

2. Open the seat support.
3. Remove the transmission belt and the jackshaft belt.
4. Loosen the fan bracket mounting screws, unthread the adjustment bolt, and slide the bracket forward.

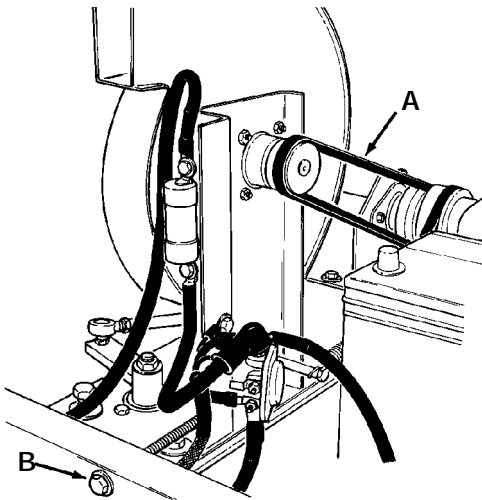

VACUUM FAN BELT

- A. Vacuum Fan Belt**
- B. Adjustment Bolt**

5. Remove the existing belt.
6. Position the new belt on the sheaves.
7. Pull the fan bracket backward, snug the belt, and tighten the bracket mounting bolts.
8. Replace the transmission belt and the

jackshaft belt.

9. Check the alignment and tension of the belt as described in *DRIVE CHAIN AND BELT ALIGNMENT AND TENSIONING*.
10. Close seat support.

TRANSMISSION BELT

The transmission belt transfers power from the motor sheave to the transmission. Check the belt condition and tension after every 50 hours of operation as described in *DRIVE CHAIN AND BELT ALIGNMENT AND TENSIONING*.

TO REPLACE TRANSMISSION BELT

1. Stop the motor and set the parking brake.

FOR SAFETY: Before Leaving Or Servicing Machine; Stop On Level Surface, Set Parking Brake, And Turn Off Machine.

2. Open the seat support.
3. Remove the jackshaft belt.
4. Unhook the transmission belt tension spring.

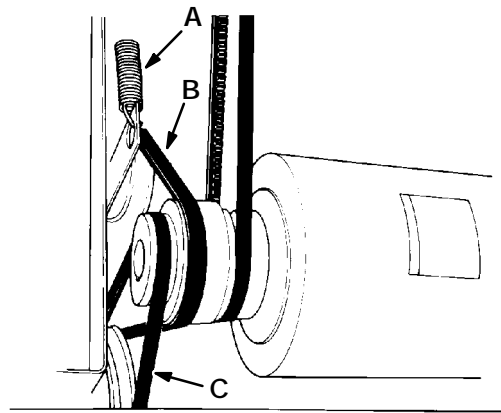

TRANSMISSION BELT

- A. Belt Tension Spring**
- B. Transmission Belt**
- C. Jackshaft Belt**

5. Remove the transmission belt.
6. Position a new transmission belt on the sheaves.

MAINTENANCE

7. Rehook the belt tension spring.
8. Replace the jackshaft belt.
9. Check the alignment of the belt as described in *DRIVE CHAIN AND BELT ALIGNMENT AND TENSIONING*.
10. Close the seat support.

JACKSHAFT BELT

The jackshaft belt transfers power from the motor sheave to the jackshaft. Check the belt condition and tension after every 50 hours of operation as described in *DRIVE CHAIN AND BELT ALIGNMENT AND TENSIONING*.

TO REPLACE JACKSHAFT BELT

1. Stop the motor and set the parking brake.

FOR SAFETY: Before Leaving Or Servicing Machine; Stop On Level Surface, Set Parking Brake, And Turn Off Machine.

2. Open the seat support.
3. Loosen the jam nut and adjustment bolt under the electric motor to relieve belt tension.

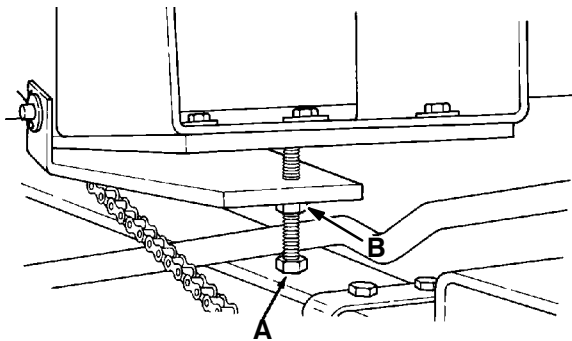

BELT ADJUSTMENT BOLT

03552

- A. Adjustment Bolt
- B. Jam Nut

4. Remove the belt.

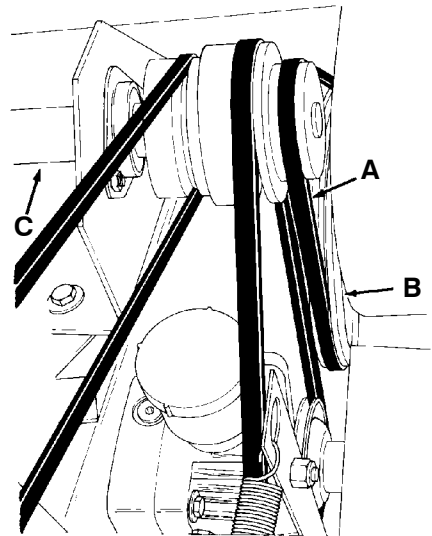

JACKSHAFT BELT

03081

- A. Jackshaft Belt
- B. Motor Sheave
- C. Jackshaft

5. Position the new belt on the sheaves.
6. Tighten the adjustment bolt until the belt snugs.
7. Check the alignment and tension the belt as described in *DRIVE CHAIN AND BELT ALIGNMENT AND TENSIONING*.
8. Close the seat support.

INTERMEDIATE SIDE BRUSH BELT

The intermediate side brush belt transfers power from the jackshaft to the side brush belt. Check the belt condition and tension after every 50 hours of operation.

TO REPLACE INTERMEDIATE SIDE BRUSH BELT

1. Stop the motor and set the parking brake.

FOR SAFETY: Before Leaving Or Servicing Machine; Stop On Level Surface, Set Parking Brake, And Turn Off Machine.

2. Open the seat support.
3. Remove the right side access door.
4. Remove the plug button from the right side of the machine frame.

5. Disconnect the main brush belt idler spring.
6. Remove the allen head socket cap screw from the end of the jackshaft. Remove the small sheave from the end of the jackshaft.
7. Remove the intermediate belt guide and belt.
8. Position the new belt on the large intermediate belt sheave. Secure the belt guide to the bracket.
9. Position the intermediate belt over the small intermediate belt sheave. Be sure the main brush belt is on its sheave.
10. Secure the sheaves to the jackshaft with the allen head socket cap screw. Check sheave alignment.
11. Reconnect the main brush belt idler spring.
12. Reinstall the right side access door and machine frame plugbutton.
13. Close the seat support.

SIDE BRUSH BELT

The side brush belt transfers power from the intermediate side brush belt to the side brush. Check the belt condition after every 50 hours of operation.

TO REPLACE SIDE BRUSH BELT

1. Stop the motor and set the parking brake.

FOR SAFETY: Before Leaving Or Servicing Machine; Stop On Level Surface, Set Parking Brake, And Turn Off Machine.

2. Place the side brush position lever in the (Side Brush Up) position.
3. Open the seat support.
4. Remove the front right machine frame end cap.
5. Remove the front side brush sheave retaining bolt.

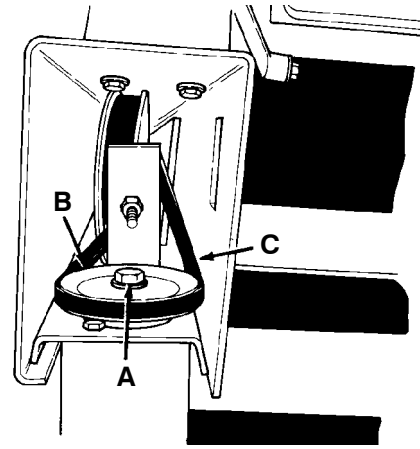

SIDE BRUSH BELT

01794

- A. Sheave Retaining Bolt**
- B. Front Sheave**
- C. Side Brush Belt**

6. Remove the existing belt.
7. Position the rear of the new belt over the rear sheave.
8. Position the front of the new belt over the loose sheave. Be sure that the top of the belt on the rear sheave goes to the left side of the front sheave. If this is reversed, the side brush will rotate the wrong direction.
9. Secure the front sheave to the side brush shaft.
10. Replace the front machine frame end cap.
11. Close the seat support.

MAIN BRUSH BELT

The main brush belt transfers power from the jackshaft to the main brush. Check the belt condition after every 50 hours of operation.

TO REPLACE MAIN BRUSH BELT

1. Stop the motor and set the parking brake.

FOR SAFETY: Before Leaving Or Servicing Machine; Stop On Level Surface, Set Parking Brake, And Turn Off Machine.

2. Open the seat support.
3. Remove the right side access door.

MAINTENANCE

4. Remove the plugbutton from the right side of the machine frame.

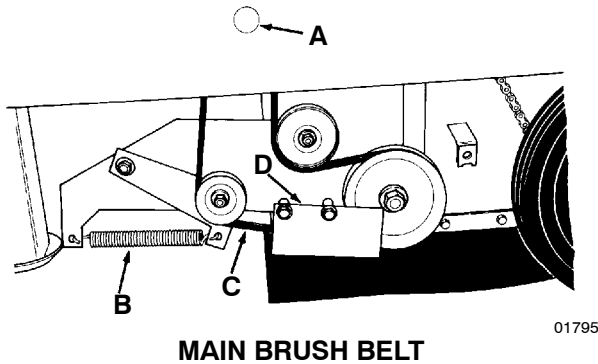

- A. Plugbutton
- B. Belt Idler Spring
- C. Main Brush Belt
- D. Belt Guard

5. Disconnect the main brush belt idler spring.
6. Remove the allen head socket cap screw from the end of the jackshaft. Remove the sheaves from the jackshaft. Remove the main brush belt.
7. Position the new belt on the sheaves.
8. Position the main brush belt on the large end sheave and the intermediate side brush belt on the small end sheave. Secure the sheaves to the end of the jackshaft with the allen head socket cap screw.
9. Check the sheave alignment.
10. Reconnect the main brush drive belt idler spring.
11. Replace the machine frame plugbutton and right side access door.
12. Close the seat support.

DRIVE CHAIN AND BELT ALIGNMENT AND TENSIONING

The chains and belts used on this machine must be properly aligned and tensioned in order for the machine to operate properly. Belts out of alignment do not stay on sheaves and wear or break more frequently. Sheave alignment can be checked as described by placing a straightedge across the sheave faces. Be sure to align and tension the belts in the order given.

TO ALIGN AND TENSION DRIVE CHAINS AND BELTS

1. Stop the motor and set the parking brake.

FOR SAFETY: Before Leaving Or Servicing Machine; Stop On Level Surface, Set Parking Brake, And Turn Off Machine.

2. Open the seat support.
3. Check the differential sprocket to transmission sprocket alignment. If they are not lined up, loosen the differential bearing locking collars, align the sprockets, and tighten the locking collars.
4. Check the transmission to differential chain tension. There should be 0.5 in (15 mm) slack measured midway between the sprockets. To adjust the tension, loosen the transmission mounting bolts, slide the transmission forward to increase slack or backward to decrease slack, and tighten the transmission bolts.

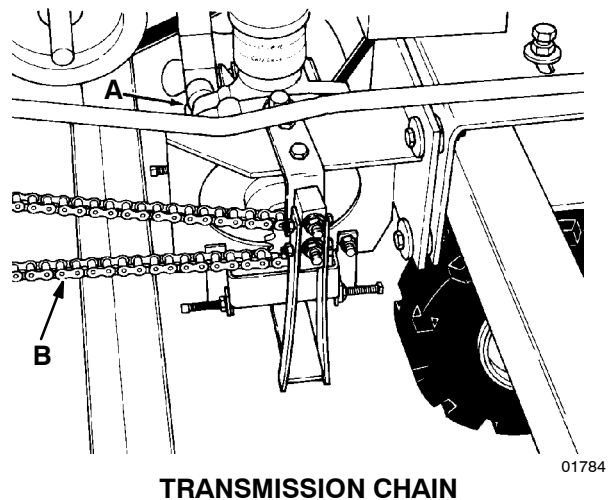

- A. Transmission
- B. Chain

5. Check the alignment of the differential to wheel chain sprockets. If they are not lined up, loosen the differential sprocket set screws, align the sprockets, and tighten the set screws.

- Check the differential to wheel chain tension. There should be 0.5 in (15 mm) slack measured midway between the sprockets. To adjust tension, loosen the two wheel pivot plate bolts, turn the adjustment bolts forward to tighten the chain or backward to loosen the chain, and tighten the two wheel pivot plate bolts and jam nuts.

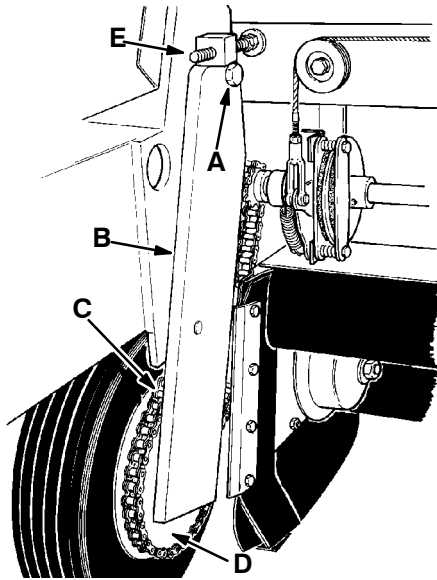

WHEEL DRIVE CHAIN

03073

- A. Pivot Plate Bolts**
- B. Wheel Pivot Plate**
- C. Chain**
- D. Chain Sprocket**
- E. Adjustment Bolt**

- Check the alignment of the jackshaft sheave to the transmission sheave. If they are not lined up, loosen the sheave set screws, align the sheave, and retighten the set screws. The belt is automatically tensioned by an idler spring assembly.

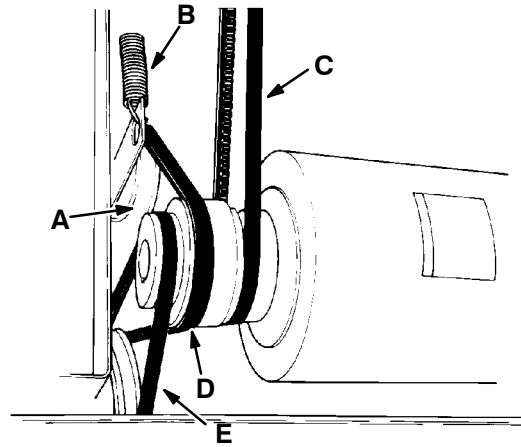

DRIVE BELTS

03090

- A. Transmission Sheave**
- B. Transmission Belt Spring**
- C. Vacuum Fan Belt**
- D. Motor Sheave**
- E. Jackshaft Belt**

- Check the alignment of the motor sheave with the jackshaft sheave. If they are not lined up, loosen the jackshaft sheave set screws, align the sheaves, and retighten the set screws.

- Check the jackshaft belt tension. There should be 0.08 in (2 mm) deflection from a force of 13 lb (6 kg) applied at belt span midpoint. To adjust tension, adjust the belt adjustment bolt under the electric motor; tighten jam nut.

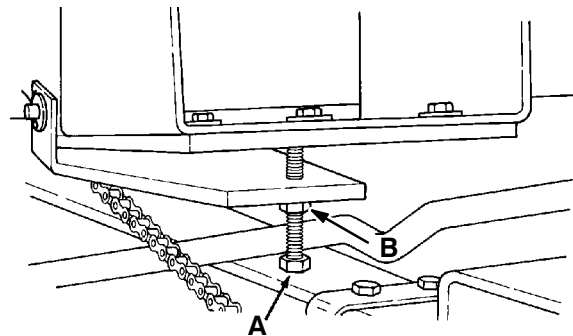

ADJUSTMENT BOLT

03552

- A. Adjustment Bolt**
- B. Jam Nut**

10. Check the alignment of the vacuum fan sheave with the jackshaft sheave. If they are not lined up, loosen the fan bracket mounting bolts, align the sheaves, and retighten the mounting bolts.
11. Check the vacuum fan belt tension. There should be 0.18 in (5 mm) deflection from a force of 8 lb (4 kg) applied at belt span midpoint. To adjust tension, loosen the fan bracket mounting bolts, slide the fan bracket forward to loosen or backward to tighten the belt, and retighten the mounting bolts. Recheck the sheave alignment.
12. Make sure the main brush belt clears the belt guard.

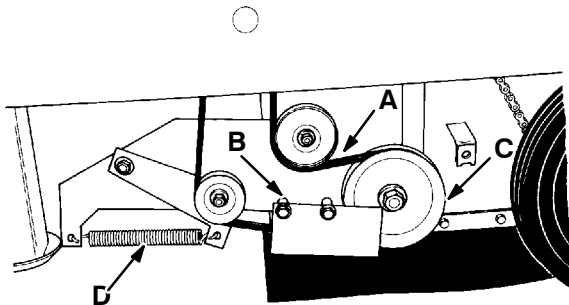

MAIN BRUSH BELT GUARD

01795

- A. Main Brush Belt**
- B. Belt Guard**
- C. Main Brush Sheave**
- D. Belt Idler Spring**

13. Check the alignment of the small jackshaft sheave to the main brush sheave. If they are not lined up, loosen the jackshaft bearing locking collars, align the sheaves, and tighten the locking collars. The belt is automatically tensioned by an idler spring assembly.
14. Measure the length of the jackshaft belt tension spring. It should be 6.5 in (165 mm). To adjust the spring length, unhook the spring. Loosen the adjustable idler bolt and slide the idler forward to reduce spring length or backward to increase spring length. Tighten the adjustable idler bolt and rehook the belt tension spring. Repeat procedure as required.
15. Close the seat support.

STATIC DRAG CHAIN

The static drag chain prevents the buildup of static electricity in the machine. It is attached to the rear skirt retaining strip.

Make sure that the chain is making contact with the floor at all times.

DEBRIS HOPPER AND DUST FILTER

DEBRIS HOPPER

The debris hopper collects debris swept by the machine. It should be dumped after every work shift. It should also be flushed out after every 100 hours of operation. The hopper floor clearance should be checked and adjusted if necessary after every 100 hours of operation.

TO CHECK AND ADJUST HOPPER FLOOR CLEARANCE

1. Empty the hopper and park the machine on a smooth, level surface.
2. Place the hopper in the "operating" position.
3. Stop the motor and set the parking brake.

FOR SAFETY: Before Leaving Or Servicing Machine; Stop On Level Surface, Set Parking Brake, And Turn Off Machine.

4. Check the distance between the floor and the bottom edge of the hopper. It should be equal side to side. To adjust the hopper floor clearance, raise the hopper and adjust the hopper stop bolts. A good starting point is to adjust both bolts so they extend 1.25 in (30 mm) from their mounting position.

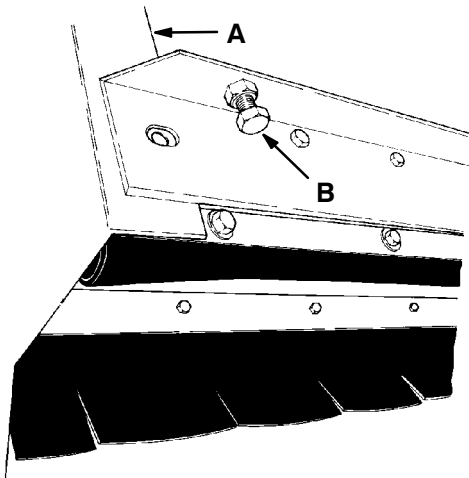

HOPPER STOP BOLTS

- A. Hopper**
- B. Stop Bolts**

03084

HOPPER DUST FILTER

The hopper dust filter filters the air which is drawn up from the main brush compartment by the vacuum fan. It is located inside the dust filter compartment. Shake the excess dust from the filter daily. Inspect and clean or replace the dust filter after every 50 hours of operation.

To clean the dust filter use one of the following methods:

- **TAPPING** - Tap the filter gently on a flat surface with the dirty side down. Do not damage the edges of the filter element or the filter will not seat properly in the filter frame.
- **AIR** - Blow compressed air, 35 psi (240 kPa) maximum, through the dust filter opposite the direction of the arrows. This may be done with the filter in the machine. Always wear eye protection when using compressed air.
- **WATER** - Soak the dust filter in a water and mild detergent solution. Rinse the dust filter until it is clean. The maximum water pressure allowable is 40 psi (275 kPa). Air dry the wet filter; do not use compressed air.

NOTE: Be sure the dust filter is dry before reinstalling it in the machine.

MAINTENANCE

TO REMOVE AND REPLACE HOPPER DUST FILTER

1. Stop the motor and set the machine parking brake.

FOR SAFETY: Before Leaving Or Servicing Machine; Stop On Level Surface, Set Parking Brake, And Turn Off Machine.

2. Unthread the four front filter cover screws and remove the front filter cover.

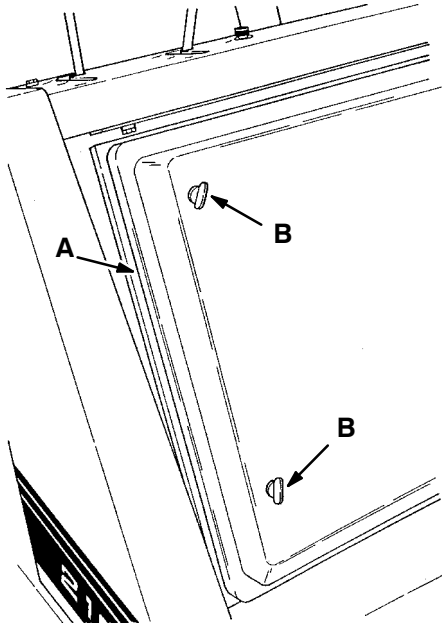

FRONT FILTER COVER

03082

- A. Filter Cover
- B. Filter Cover Screw

3. Unplug the shaker motor leads and remove the shaker motor and springs assembly. Remove the dust filter.

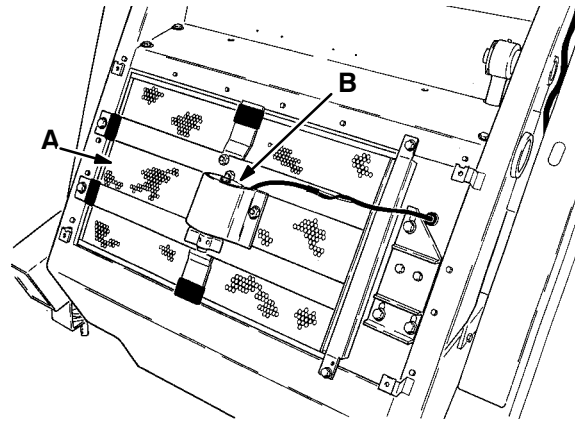

DUST FILTER

03083

- A. Dust Filter
- B. Shaker Motor Assembly

4. Inspect and clean or replace the dust filter.
5. Position the dust filter in the filter frame with the arrows pointing toward the machine.
6. Secure the filter with the shaker motor and springs assembly. Plug the shaker motor leads together.
7. Secure the front filter cover on the filter frame with the four screws.

SKIRTS AND SEALS

BRUSH SKIRTS

Brush skirts control main brush dusting. They are located on each of the side access doors. The skirts should be inspected for wear or damage daily. They should clear the floor by 0 to 0.12 in (0 to 5 mm) at all times.

TO ADJUST BRUSH SKIRTS

1. Park the machine on a smooth, level floor.
2. Stop the motor and set the parking brake.

FOR SAFETY: Before Leaving Or Servicing Machine; Stop On Level Surface, Set Parking Brake, And Turn Off Machine.

3. Unlatch and open the left side access door.
4. Loosen the skirt and retaining strip. Adjust the skirt height, retighten the retaining strip, and close and latch the door.
5. Check the skirt clearance.
6. Loosen the two right side access door screws and remove the right side access door.

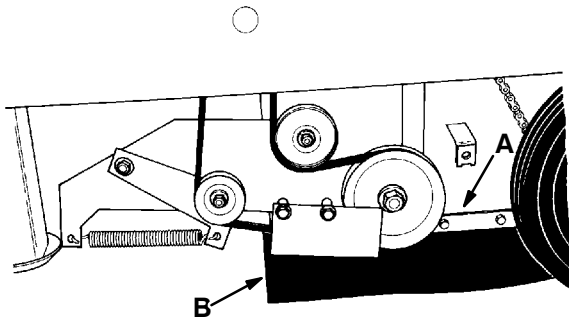

RIGHT SIDE SKIRT

01795

- A. Retaining Strip**
- B. Side Skirt**

7. Loosen the skirt retaining strip, adjust the skirt height, and retighten the retaining strip.
8. Check the skirt clearance.
9. Reinstall the right side access door.

TO REPLACE BRUSH SKIRTS

1. Park the machine on a smooth, level floor.
2. Stop the motor and set the parking brake.

FOR SAFETY: Before Leaving Or Servicing Machine; Stop On Level Surface, Set Parking Brake, And Turn Off Machine.

3. Unlatch and open the left side access door.
4. Remove the skirt retaining strip and the brush skirt.
5. Loosely install the new dust skirt with the retaining strip.
6. Close the access door and check the floor clearance.
7. Adjust the skirt so that it clears the floor by 0 to 0.12 in (0 to 5 mm) and tighten the retaining strip screws.
8. Close and latch the left access door.
9. Loosen the two right side access door screws and remove the right side access door.
10. Remove the skirt retaining strips and the brush skirt.
11. Loosely install the new brush skirt with the retaining strips.
12. Adjust the skirt so that it clears the floor by 0 to 0.12 in (0 to 5 mm) and tighten the retaining strip screws.
13. Reinstall the right side access door.

HOPPER SEALS

Three seals control hopper dusting. They are the hopper top seal, and the left and right side hopper seals. They should be inspected daily for wear or damage.

TO REPLACE HOPPER SEALS

1. Empty the debris hopper.
2. Raise the hopper.
3. Engage the hopper support bar.

! WARNING: Raised Hopper May Fall. Engage Hopper Support Bar.

4. Stop the motor and set the parking brake.

FOR SAFETY: Before Leaving Or Servicing Machine; Stop On Level Surface, Set Parking Brake, And Turn Off Machine.

5. Remove the retaining strip of the seal or skirt to be replaced.

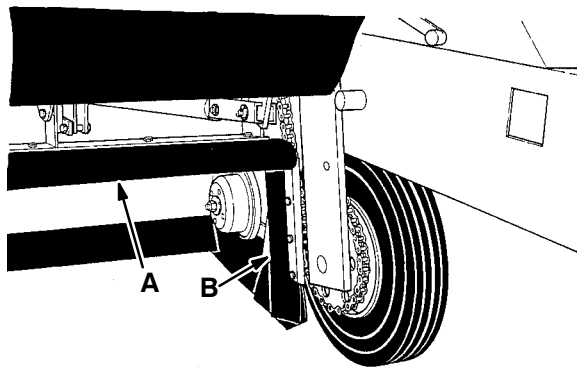

03066

HOPPER SEALS AND SKIRT

- A. Hopper Top Seal**
- B. Hopper Side Seal**

6. Remove the existing seal or skirt.
7. Mount the new seal to the machine with the retaining strip removed earlier.
8. Raise the hopper, disengage the hopper support bar, and lower the hopper.

HOPPER DUMP DOOR SEAL

The hopper dump door seal is present on multi-level dump model machines. It allows the hopper to be high dumped without scattering debris. Check the seal for damage daily.

TO REPLACE HOPPER DUMP DOOR SEAL

1. Empty the debris hopper.
2. Raise the hopper.
3. Engage the hopper support bar.

! WARNING: Raised Hopper May Fall. Engage Hopper Support Bar.

4. Stop the motor and set the parking brake.

FOR SAFETY: Before Leaving Or Servicing Machine; Stop On Level Surface, Set Parking Brake, And Turn Off Machine.

5. Open the dump door.
6. Remove the seal retaining strip.

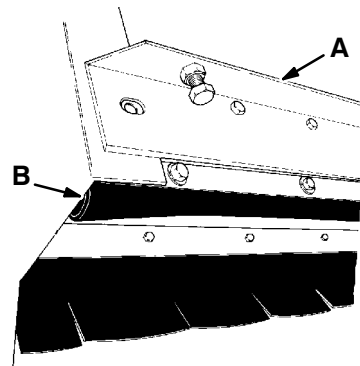

03084

HOPPER DUMP DOOR SEAL

- A. Hopper**
- B. Dump Door Seal**

7. Remove the seal.
8. Mount the new seal to the door with the retaining strip removed earlier.
9. Raise the hopper, disengage the hopper support bar, and lower the hopper.

REAR SKIRTS

The rear skirts seal the brush compartment. They are located on the bottom rear of the brush compartment. The seals should be inspected for wear or damage daily.

TO REPLACE AND ADJUST REAR SKIRTS

1. Stop the machine on a smooth, level surface.
2. Stop the motor and set the machine parking brake.

FOR SAFETY: Before Leaving Or Servicing Machine; Stop On Level Surface, Set Parking Brake, And Turn Off Machine.

3. Unlatch and open the left side access door.
4. Loosen the two right side access door screws and remove the right side access door.
5. Remove the rear skirt retaining strips and the rear skirts.

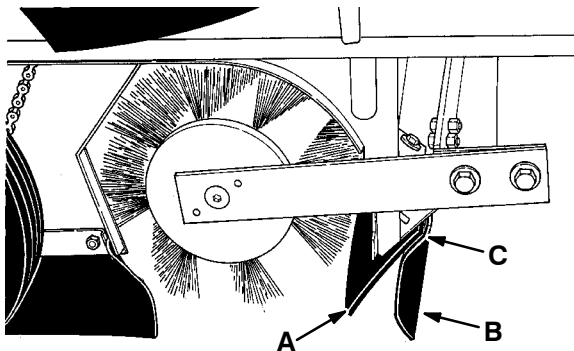

REAR SKIRTS

01802

- A. Brush Skirt
- B. Vertical Rear Skirt
- C. Retaining Strip

6. Loosely install new skirts with the existing retaining strips.
7. Slide the vertical rear skirt up or down so it is 0 to 0.12 in (0 to 5 mm) above the floor.
8. Retighten the retaining strip bolts.

HOPPER LIP SKIRT

The hopper lip skirt floats over debris and helps deflect that debris into the hopper. It is located on the bottom rear of the hopper.

The hopper lip skirt should be inspected for wear or damage daily.

TO REPLACE HOPPER LIP SKIRT

1. Empty the machine debris hopper.
2. Raise the hopper.
3. Engage the hopper support bar.

! WARNING: Raised Hopper May Fall. Engage Hopper Support Bar.

4. Stop the machine on a level surface, stop the motor, and set the machine parking brake.

FOR SAFETY: Before Leaving Or Servicing Machine; Stop On Level Surface, Set Parking Brake, And Turn Off Machine.

5. Remove the skirt retaining strip and the skirt.

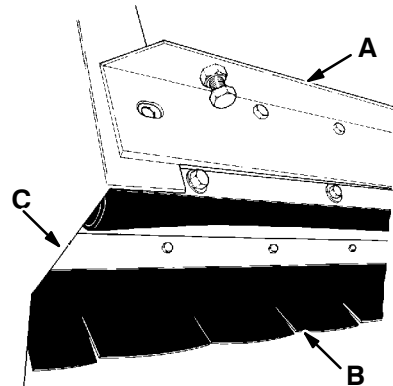

HOPPER LIP SKIRT

03084

- A. Hopper
- B. Lip Skirt
- C. Retaining Strip

6. Position the new skirt on the hopper. Secure it in place with the retaining strip.
7. Raise the hopper, disengage the hopper support bar, and lower the hopper.

BRUSHES

MAIN BRUSH

The main brush is tubular and spans the width of the machine, sweeping debris into the debris hopper. It should be inspected daily for wear or damage. Remove any string or wire found tangled on the main brush, main brush drive hub, or main brush idler hub.

Rotate the main brush end-for-end after every 50 hours of operation for maximum brush life and best sweeping performance.

The main brush pattern should be checked daily. It should be 2 to 2.5 in (50 to 65 mm) wide with the main brush in the (Main Brush Down) position. Main brush pattern adjustments are made by turning the height adjustment knob on the instrument panel.

The main brush should be replaced when the remaining bristles measure 1.25 in (30 mm) or less in length.

TO REMOVE MAIN BRUSH

1. Stop motor and set the machine parking brake.

FOR SAFETY: Before Leaving Or Servicing Machine; Stop On Level Surface, Set Parking Brake, And Turn Off Machine.

2. Place the main brush position lever in the (Main Brush Down) position.
3. Open the left side access door.
4. Remove the brush idler arm retaining bolts from the arm hub.

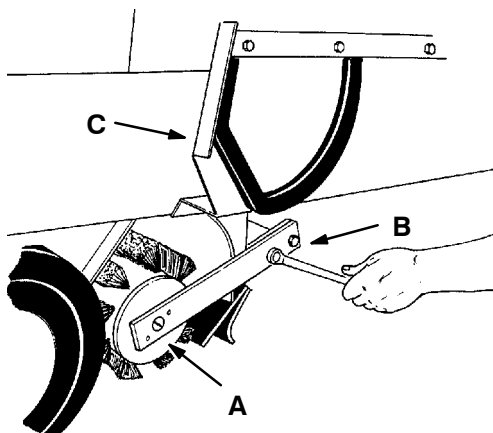

01128

REMOVING MAIN BRUSH IDLER ARM

- A. Brush Idler Arm
- B. Arm Retaining Bolt
- C. Access Door

5. Pull the brush idler arm off the arm hub.
6. Grasp the main brush, pull it off the brush drive plug, and out of the main brush compartment.

TO INSTALL MAIN BRUSH

1. Place main brush on the floor next to the access door.
2. Align the main brush drive slots with the drive keys on the main brush drive plug.
3. Slide the main brush into the brush compartment and onto the drive plug. Make sure the drive slots and keys mate.

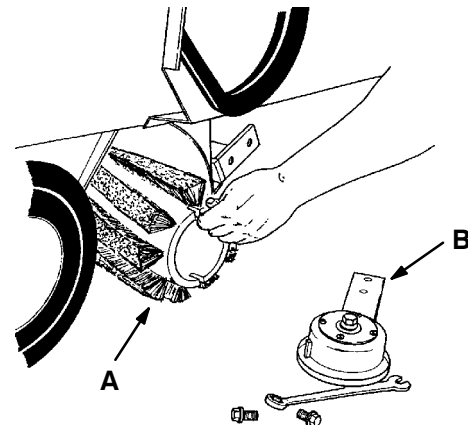

01129

INSTALLING MAIN BRUSH

- A. Main Brush
- B. Idler Arm

4. Align the main brush idler plug slots with the main brush keys.
5. Slide the main brush idler plug into the main brush tube.
6. Slide the brush idler arm onto the arm hub.
7. Thread the brush idler arm retaining bolts through the idler arm and into the arm hub.
8. Tighten the brush idler arm retaining bolts.

9. Close the left side access door.
10. Check and adjust the main brush pattern as described in *TO CHECK AND ADJUST MAIN BRUSH PATTERN*.

TO CHECK AND ADJUST MAIN BRUSH PATTERN

1. Apply chalk, or some other material that will not blow away easily, to a smooth, level floor.
2. With the side brush and main brush raised, position the main brush over the chalked area.
3. Place the main brush position lever in the (Main Brush Down) position for 15 to 20 seconds while keeping a foot on the brakes to keep the machine from moving. This will lower the rotating main brush.
4. Place the main brush position lever in the (Main Brush Up) position.

NOTE: If chalk or other material is not available, allow the brushes to spin on the floor for two minutes. A polish mark will remain on the floor.

5. Drive the machine off the test area.

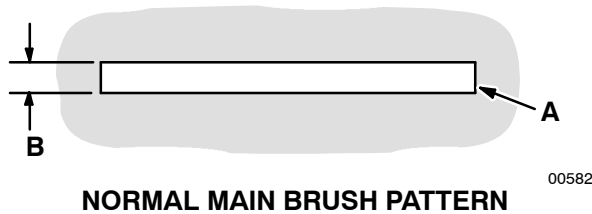

NORMAL MAIN BRUSH PATTERN

- A. Main Brush Pattern**
- B. Pattern Width**

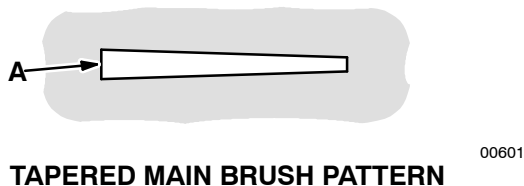

TAPERED MAIN BRUSH PATTERN

- A. Main Brush Pattern**

The pattern should be of equal width across the length of the pattern. If the main brush pattern is tapered, wider on one side by 0.50 in (15 mm) or more than the other side, perform the following leveling procedure:

- A. Park the sweeper on a level surface, raise the main brush, stop the motor, and set the parking brake.

FOR SAFETY: Before Leaving Or Servicing Machine; Stop On Level Surface, Set Parking Brake, And Turn Off Machine.

- B. Open the left side access door.
- C. Remove the main brush.
- D. Reinstall the idler arm. Let the front of the arm drop to take up the slack in the holes. Retighten the screws.
- E. Place a block under the brush idler plug and release the brush lift handle.
- F. Remove the right side access door.
- G. Remove the brush drive belt from the spring idler sheave and allow the idler arm to hang down.
- H. Loosen the two Hex head screws and move the drive assembly up or down to center it the same distance from the floor as the idler arm to obtain an even pattern. Retighten the screws.
- I. Replace the drive belt and remove the block from under the brush idler arm.
- J. Reinstall the main brush.
- K. Recheck the main brush pattern to see if the main brush is level.
- L. Replace the right side access door and close the left side access door.

The pattern should be 2 to 2.5 in (50 to 55 mm) wide. If the main brush pattern is too narrow, turn the main brush height adjustment knob clockwise. If the main brush pattern is too wide, turn the main brush height adjustment knob counterclockwise. Recheck the pattern width after making any adjustments.

SIDE BRUSH

The side brush sweeps debris from curbs or gutters into the path of the main brush. It should be inspected daily for wear or damage. Remove any string or wire found tangled on the side brush or side brush drive hub.

The side brush pattern should be checked daily. Between one-third and one-half of the side brush bristles should contact the floor when the brush is in motion. The side brush pattern adjustment is made by removing the side brush attaching hardware, repositioning the side brush assembly, and replacing the hardware.

The side brush should be replaced when the remaining brush bristle measures 2.5 in (65 mm) in length.

TO INSTALL SIDE BRUSH

1. Slide the side brush onto the side brush drive shaft.
2. Insert the side brush retaining bolt through the side brush hub and shaft.
3. Thread a nut onto the threads of the bolt.
4. Tighten the nut and bolt to secure the side brush.

TO REMOVE SIDE BRUSH

1. Stop the motor and set the machine parking brake.

FOR SAFETY: Before Leaving Or Servicing Machine; Stop On Level Surface, Set Parking Brake, And Turn Off Machine.

2. Place the side brush position lever in the (Side Brush Up) position.
3. Remove the side brush retaining bolt from the side brush hub and shaft.

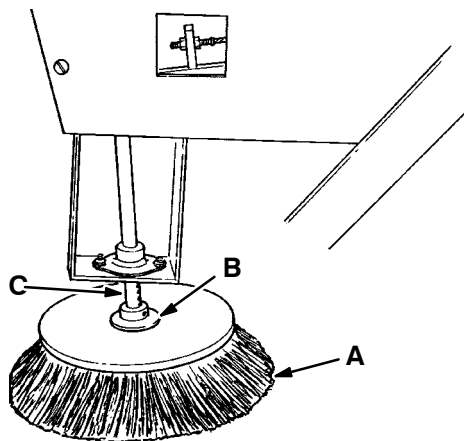

SIDE BRUSH

01127

- A. Side Brush**
- B. Retaining Bolt**
- C. Side Brush Drive Shaft**

4. Slide the side brush off the side brush drive shaft.

TRANSMISSION

TRANSMISSION

The transmission drives the two front wheels. Check the oil level after every 25 hours of operation by looking at the reservoir mounted on top of the transmission. The cold oil level should be 0 to 0.25 in (0 to 5 mm) above the cold mark. Use straight SAE 20-weight, API class SF engine oil.

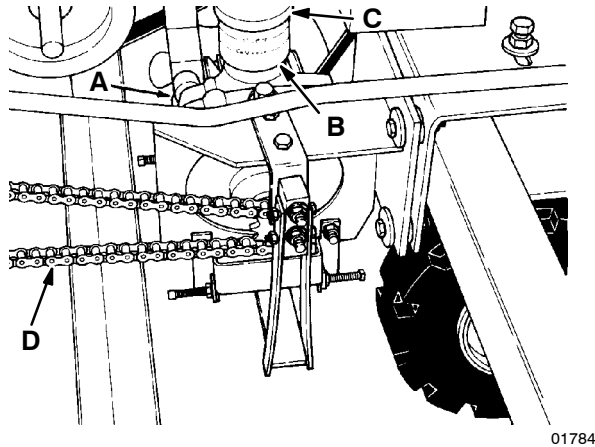

TRANSMISSION

- A. Transmission**
- B. Oil Reservoir**
- C. Fill Cap**
- D. Transmission Chain**

Proper cooling is essential to both performance and life of the transmission. Keep the fan and cooling fins clean.

ATTENTION! Cleaning the transmission with high pressure water spray or live steam may allow water to enter the reservoir. A few drops of water in the system will result in loss of oil, and loss of power.

If contaminants are observed on the reservoir screen, remove, wash and clean it. If the reservoir screen has been pierced, internal failure may occur. The damaged reservoir should be replaced. If the transmission oil color has changed to black or milky, overheating and/or water contamination is indicated. The oil should be drained and replaced with new oil.

NOTE: The threads connecting the plastic reservoir to the aluminum cover are "left hand."

To drain transmission oil, first blow all dirt from the reservoir and vent plug. Remove the drain plug in the bottom of the transmission and the vent plug in the top. Allow the transmission to drain completely, replace the lower plug, and refill the transmission through reservoir with new SAE 20-weight engine oil. Rotate input and output shafts to purge any air trapped in the unit and fill until oil overflows the vent plug opening. Replace the vent plug and fill the reservoir to the "cold" mark.

TRANSMISSION LINKAGE

The transmission linkage controls the transmission. It has four adjustments. They are control rod length, forward stop, rear stop, and pintle arm centering. These adjustments need no regular checks. However, they should be checked if any of the linkage parts is replaced or if the transmission position is changed.

The control rod and ball joints between the directional control pedal and the pintle arm should be adjusted so that the full stroke of the transmission may be obtained without interference from anything other than the stop bolts.

The forward stop bolt should be adjusted so that the threaded end of the bolt is 0.06 to 0.12 in (2 to 5 mm) from the bracket.

The rear stop bolt should be adjusted so that the threaded end of the bolt is 1 in (25 mm) from the bracket.

The centering springs should be adjusted so that the pintle arm returns the transmission to the "neutral" position without machine creeping.

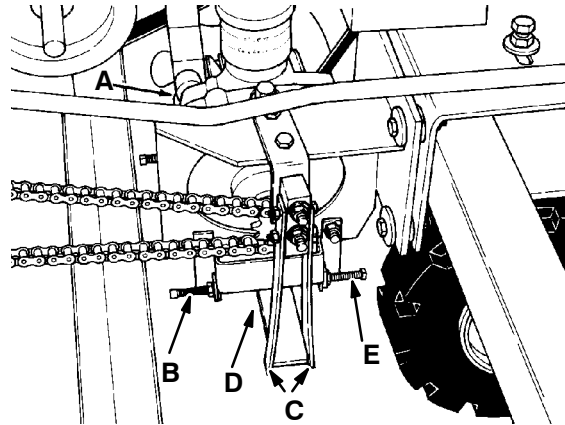

01784

TRANSMISSION LINKAGES

- A. Transmission**
- B. Forward Stop Bolt**
- C. Centering Spring**
- D. Pintle Arm**
- E. Rear Stop Bolt**

BRAKES AND TIRES**BRAKES**

The parking brake and the foot brake operate the brake cable which controls two disc brakes.

The brakes should be adjusted after every 100 hours of operation. The brakes are properly adjusted when the parking brake lever will travel 0.50 in (15 mm) before engaging the brakes.

To adjust the brakes, remove the clevis pin from each brake assembly, turn the clevis ends an equal amount, reconnect the clevis pins, and recheck the parking brake lever travel.

TIRES

All of the machine tires are solid and need no regular maintenance.

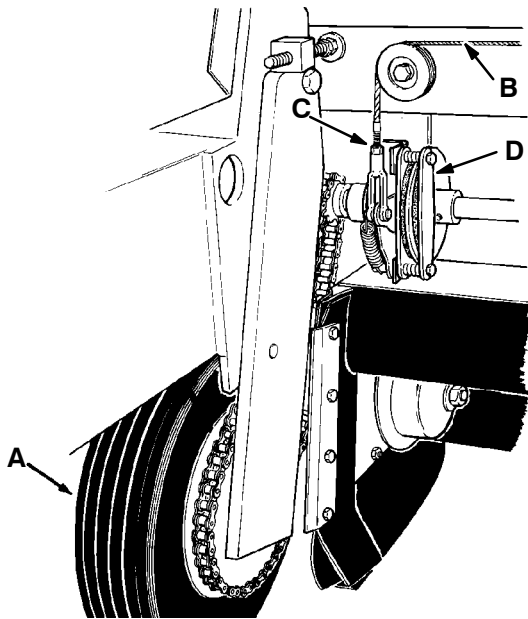
**BRAKE ASSEMBLY**

03073

- A. Right Side Tire**
- B. Brake Cable**
- C. Clevis**
- D. Brake Assembly**

SECTION 4

CONTENTS

	Page
HARDWARE INFORMATION	4-3
STANDARD BOLT TORQUE CHART ..	4-3
METRIC BOLT TORQUE CHART	4-3
BOLT IDENTIFICATION	4-3
THREAD SEALANT AND LOCKING COMPOUNDS	4-3
HYDRAULIC FITTING INFORMATION	4-4
HYDRAULIC TAPERED PIPE FITTING (NPT) TORQUE CHART	4-4
HYDRAULIC TAPERED SEAT FITTING (JIC) TORQUE CHART	4-4
HYDRAULIC O-RING FITTING TORQUE CHART	4-4

HARDWARE INFORMATION

The following charts state standard plated hardware tightening ranges for normal assembly applications. Decrease the specified torque by 20% when using a thread lubricant. Do not substitute lower grade hardware for higher grade hardware. If higher grade hardware than specified is substituted, tighten only to the specified hardware torque value to avoid damaging the threads of the part being threaded into, as when threading into speed nuts or weldments.

STANDARD BOLT TORQUE CHART

Thread Size	SAE Grade 5 Torque ft lb (Nm)	SAE Grade 8 Torque ft lb (Nm)
0.25 in	7-10 (9-14)	10-13 (14-38)
0.31 in	15-20 (20-27)	20-26 (27-35)
0.38 in	27-35 (37-47)	36-47 (49-64)
0.44 in	43-56 (58-76)	53-76 (72-103)
0.50 in	65-85 (88-115)	89-116 (121-157)
0.62 in	130-170 (176-231)	117-265 (159-359)
0.75 in	215-280 (291-380)	313-407 (424-552)
1.00 in	500-650 (678-881)	757-984 (1026-1334)

NOTE: Decrease torque by 20% when using a thread lubricant.

METRIC BOLT TORQUE CHART

Thread Size	Class 8.8 Torque ft lb (Nm)	Class 10.9 Torque ft lb (Nm)
M4	2 (3)	3 (4)
M5	4 (5)	6 (8)
M6	7 (9)	10 (14)
M8	18 (24)	25 (34)
M10	32 (43)	47 (64)
M12	58 (79)	83 (112)
M14	94 (127)	133 (180)
M16	144 (195)	196 (265)
M20	260 (352)	336 (455)
M24	470 (637)	664 (900)

NOTE: Decrease torque by 20% when using a thread lubricant.

Exceptions to the above chart:

Main brush drive plug nut – 30 ft lb (40 Nm) then tighten to next slot.

Brake unit to hub socket head screw – 9 to 12 ft lb (12 to 16 Nm) with Locktite 242 blue.

Front wheel nut – 10 to 12 ft lb (14 to 16 Nm) while turning wheel, tighten to spec, then backoff, retighten by hand till snug, then turn to next slot.





Damper solenoid nut – 20 to 23 in lb (2.5 to 3 Nm).

Pitman arm to steering column nut – 160 ft lb (215 Nm).

Propelling motor shaft thin nylon lock nut – 7 to 10 ft lb (9 to 14 Nm).

Propelling motor adapter bolts – 16 to 21 ft lb (21 to 28 Nm) with Locktite 242 blue on threads. Use Locktite 515 sealant on the pilot fillet of the motor and the adapter.

BOLT IDENTIFICATION

Identification Grade Marking	Specification and Grade
	SAE-Grade 5
	SAE-Grade 8
	ISO-Grade 8.8
	ISO-Grade 10.9

01395

THREAD SEALANT AND LOCKING COMPOUNDS

Thread sealants and locking compounds may be used on this machine. They include the following:

Locktite 515 sealant – gasket forming material. TENNANT® Part No. 75567, 15 oz (440 ml) cartridge.

Locktite 242 blue – medium strength thread locking compound. TENNANT® Part No. 32676, 0.5 ml tube.

Locktite 271 red – high strength thread locking compound. TENNANT® Part No. 19857, 0.5 ml tube.

HYDRAULIC FITTING INFORMATION

**HYDRAULIC TAPERED PIPE FITTING (NPT)
TORQUE CHART**

NOTE: Ratings listed are when using teflon thread seal.

Size	Minimum Torque	Maximum Torque
1/4 NPT Nm)	10 ft lb (14 Nm)	30 ft lb (41)
1/2 NPT Nm)	25 ft lb (34 Nm)	50 ft lb (68)
3/4 NPT Nm)	50 ft lb (68 Nm)	100 ft lb (136)

**HYDRAULIC TAPERED SEAT FITTING (JIC)
TORQUE CHART**

Tube O.D. (in)	Thread Size	Maximum Torque
0.25	0.44-20	9 ft lb (12 Nm)
0.38 Nm)	0.56-18	20 ft lb (27)
0.50 Nm)	0.75-16	30 ft lb (41)
0.62 Nm)	0.88-14	40 ft lb (54)
0.75 Nm)	1.12-12	70 ft lb (95)
1.0 Nm)	1.31-12	90 ft lb (122)

**HYDRAULIC O-RING FITTING TORQUE
CHART**

Tube O.D.(in)	Thread Size	Minimum Torque	Maximum Torque
0.25 Nm)	0.44-20	6 ft lb (8 Nm)	9 ft lb (12)
0.38 (27 Nm)	0.56-18	13 ft lb (18 Nm)	20 ft lb
(16 Nm)		*10 ft lb (14 Nm)	12 ft lb
0.50 (41 Nm)	0.75-16	20 ft lb (27 Nm)	30 ft lb
(33 Nm)		*21 ft lb (28 Nm)	24 ft lb
0.62 (54 Nm)	0.88-14	25 ft lb (34 Nm)	40 ft lb
0.75 (95 Nm)	1.12-12	45 ft lb (61 Nm)	70 ft lb
1.0 (122 Nm)	1.31-12	60 ft lb (81 Nm)	90 ft lb

NOTE: Do not use sealant on o-ring threads.

*Aluminum bodied components