

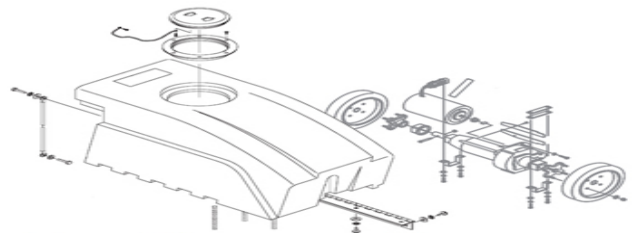

140E

(Electric)

Sweeper Operator and Parts Manual

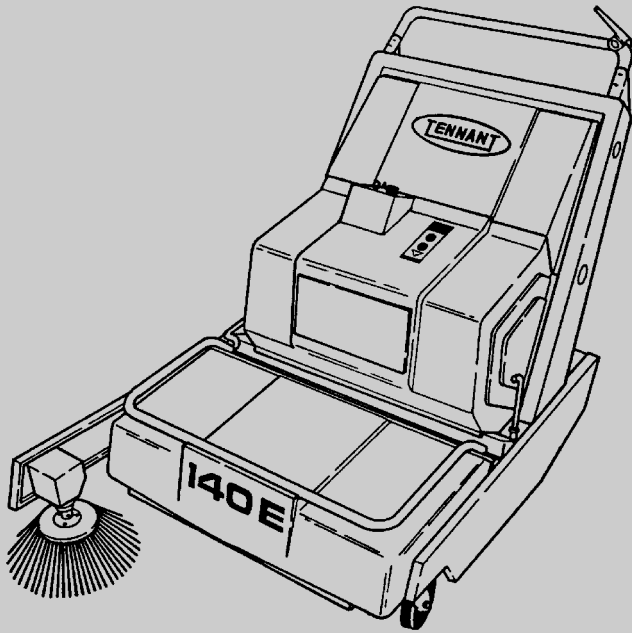

FLOOR-EQUIPMENT-PARTS.COM

North America / International

www.tennantco.com

MM156
Rev. 22 (12-2006)





This manual is furnished with each new model. It provides necessary operation and maintenance instructions.

Read this manual completely and understand the machine before operating or servicing it.

This machine will provide excellent service. However, the best results will be obtained at minimum costs if:

- The machine is operated with reasonable care.
- The machine is maintained regularly - per the machine maintenance instructions provided.
- The machine is maintained with manufacturer supplied or equivalent parts.

	PROTECT THE ENVIRONMENT Please dispose of packaging materials, old machine components such as batteries, hazardous fluids such as antifreeze and oil, in an environmentally safe way according to local waste disposal regulations.
	Always remember to recycle.

MACHINE DATA	
Please fill out at time of installation for future reference.	
Model No. -	_____
Serial No. -	_____
Machine Options -	_____
Sales Rep. -	_____
Sales Rep. phone no. -	_____
Customer Number -	_____
Installation Date -	_____

Tennant Company
PO Box 1452
Minneapolis, MN 55440
Phone: (800) 553-8033 or (763) 513-2850
www.tennantco.com

Specifications and parts are subject to change without notice.

Copyright © 1984, 1986 - 1992, 1994 - 1997, 2000-2004, 2006 TENNANT Company, Printed in U.S.A.

SAFETY PRECAUTIONS

The following symbols are used throughout this manual as indicated in their descriptions:



WARNING: To warn of hazards or unsafe practices which could result in severe personal injury or death.

FOR SAFETY: To identify actions which must be followed for safe operation of equipment.

The following information signals potentially dangerous conditions to the operator or equipment. Read this manual carefully. Know when these conditions can exist. Locate all safety devices on the machine. Then, take necessary steps to train machine operating personnel. Report machine damage or faulty operation immediately. Do not use the machine if it is not in proper operating condition.



WARNING: Batteries Emit Hydrogen Gas. Explosion Or Fire Can Result. Keep Sparks And Open Flame Away. Keep Covers Open When Charging.



WARNING: Brush Throws Debris. Stop Motor Before Lifting Hopper.



WARNING: Machine Moves When Motor Is Running. Stop Motor Before Leaving Machine.

FOR SAFETY:

1. **Do Not Operate Machine:**
 - **Unless Trained And Authorized.**
 - **Unless Operation Manual Is Read And Understood.**
 - **In Flammable Or Explosive Areas Unless Designed For Use In Those Areas.**
 - **In Areas With Possible Falling Objects Unless Equipped With Overhead Guard.**
2. **Before Starting Machine:**
 - **Make Sure All Safety Devices Are In Place And Operate Properly.**
3. **When Using Machine:**
 - **Go Slow On Grades And Slippery Surfaces.**
 - **Use Care When Backing Machine.**
 - **Do Not Carry Riders On Machine.**
 - **Always Follow Safety And Traffic Rules.**

4. **Before Leaving Or Servicing Machine:**
 - **Stop On Level Surface.**
 - **Turn Off Machine And Remove Key.**
5. **When Servicing Machine:**
 - **Avoid Moving Parts. Do Not Wear Loose Jackets, Shirts, Or Sleeves When Working On Machine.**
 - **Block Machine Tires Before Jacking Machine Up.**
 - **Jack Machine Up At Designated Locations Only. Block Machine Up With Jack Stands.**
 - **Use Hoist Or Jack That Will Support The Weight Of The Machine.**
 - **Wear Eye And Ear Protection When Using Pressurized Air Or Water.**
 - **Disconnect Battery Connections Before Working On Machine.**
 - **Avoid Contact With Battery Acid.**
 - **Use TENNANT Supplied Or Equivalent Replacement Parts.**
6. **When Loading/Unloading Machine Onto/Off Truck Or Trailer:**
 - **Turn Off Machine.**
 - **Use Truck Or Trailer That Will Support The Weight Of The Machine.**
 - **Use Winch. Do Not Push The Machine Onto/Off The Truck Or Trailer Unless The Load Height Is 380 mm (15 in) Or Less From The Ground.**
 - **Block Machine Tires.**
 - **Tie Machine Down To Truck Or Trailer.**

GENERAL INFORMATION

The following safety labels are mounted on the machine in the locations indicated. If these or any label becomes damaged or illegible, install a new label in its place.

MACHINE CREEPING WARNING LABEL - LOCATED ON MACHINE HANDLE FRAME.



FOR SAFETY LABEL - LOCATED ON MACHINE HANDLE FRAME.

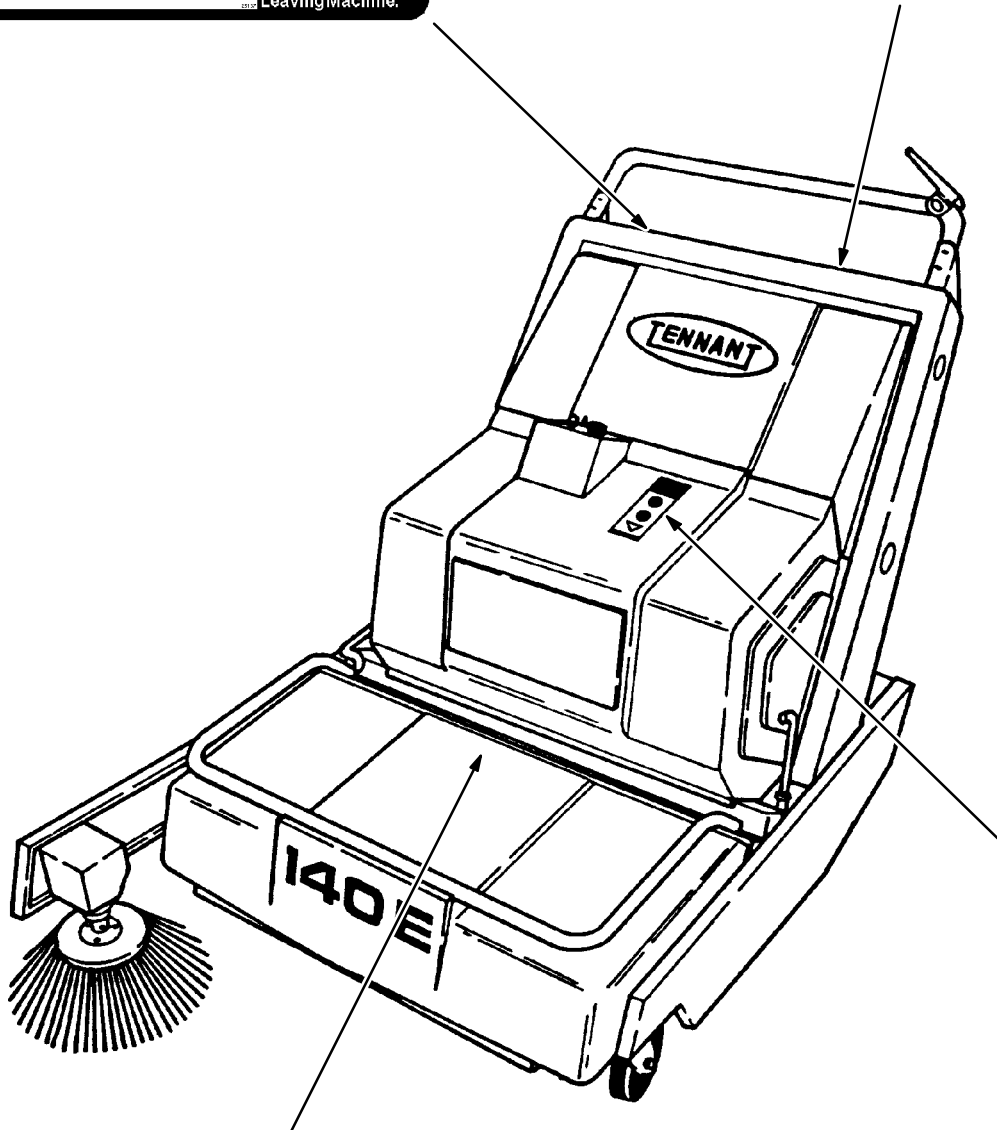

01189

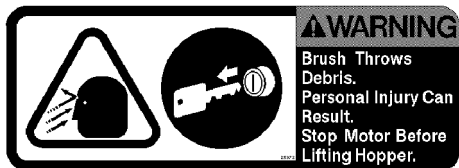

FLYING DEBRIS WARNING LABEL - LOCATED ON TOP OF HOPPER.

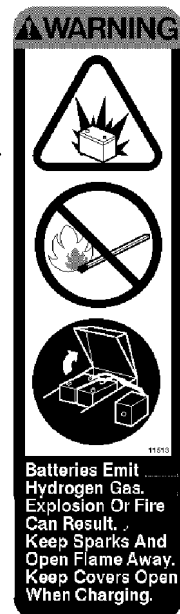

HAZARD CHARGING LABEL - LOCATED ON BATTERY COVER.

CONTENTS

	Page		Page
GENERAL INFORMATION	i	MAINTENANCE	3-1
SAFETY PRECAUTIONS	i	RECOMMENDED FIRST 20-HOUR	
SPECIFICATIONS	1-1	MACHINE INSPECTION	3-3
MACHINE SPECIFICATIONS	1-3	MAINTENANCE CHART	3-4
POWER TYPE	1-3	ELECTRICAL SYSTEM	3-6
POWER TRAIN	1-3	BATTERIES	3-6
SUSPENSION SYSTEM	1-3	BATTERY CHARGING	3-7
GENERAL MACHINE		TO CHARGE BATTERIES (For	
DIMENSIONS/CAPACITIES	1-3	machines below serial number	
MACHINE WEIGHTS	1-3	009737)	3-7
GENERAL MACHINE		TO CHARGE BATTERIES (For	
PERFORMANCE	1-3	machines serial number 009737	
MACHINE DIMENSIONS	1-4	and above)	3-8
OPERATION	2-1	ELECTRICAL SCHEMATIC (For machines	
PREPARATION FOR OPERATION	2-3	below serial number 009737) .	3-10
OPERATION OF CONTROLS	2-4	ELECTRICAL SCHEMATIC (For	
MACHINE COMPONENTS	2-4	machines serial number 009737	
CLUTCH CONTROL HANDLE	2-5	and above)	3-11
MAIN BRUSH LIFT HANDLE	2-5	BRUSHES	3-12
SIDE BRUSH	2-5	MAIN BRUSH	3-12
MAIN BRUSH REMOVAL LEVER ..	2-5	TO REMOVE MAIN BRUSH	3-12
BATTERY COVER	2-6	TO INSTALL MAIN BRUSH	3-12
MASTER POWER SWITCH	2-6	TO CHECK AND ADJUST MAIN	
SHAKER RESET PUSHBUTTON ...	2-6	BRUSH PATTERN	3-13
CLEAN FILTER PUSHBUTTON	2-6	SIDE BRUSH	3-14
MACHINE CIRCUIT BREAKER	2-6	TO REMOVE SIDE BRUSH	3-14
CHARGER TIMER SWITCH	2-7	TO INSTALL SIDE BRUSH	3-14
CHARGER PANEL	2-7	TO ADJUST SIDE BRUSH	3-14
HOUR METER	2-7	DEBRIS HOPPER AND DUST FILTER .	3-15
CHARGING RATE GAUGE	2-7	DEBRIS HOPPER	3-15
MACHINE OPERATION	2-8	TO EMPTY HOPPER	3-15
NORMAL SWEEPING OPERATION	2-8	TO ADJUST HOPPER FLOOR	
PRE-START CHECKLIST	2-8	CLEARANCE	3-15
TO START MACHINE	2-8	REAR GUIDE WHEELS	3-16
TO SWEEP	2-8	TO ADJUST REAR GUIDE	
TO DUMP HOPPER	2-9	WHEELS	3-16
POST OPERATION CHECKLIST -		HOPPER DUST FILTER	3-16
MOTOR OPERATING	2-9	TO REMOVE DUST FILTER	3-17
TO STOP MACHINE	2-9	TO INSTALL DUST FILTER	3-17
POST OPERATION CHECKLIST -		SKIRTS AND SEALS	3-18
MOTOR STOPPED	2-9	SIDE DUST SKIRTS	3-18
MACHINE TROUBLESHOOTING ..	2-10	TO ADJUST SIDE DUST SKIRTS	3-18
MACHINE STORAGE	2-11	TO REPLACE SIDE DUST	
STORING MACHINE	2-11	SKIRTS	3-18
		HOPPER SIDE SEALS	3-19
		TO REPLACE HOPPER SIDE	
		SEALS	3-19
		REAR BRUSH SKIRT	3-19
		TO REPLACE REAR BRUSH	
		SKIRT	3-19

GENERAL INFORMATION

	Page		Page
BELTS AND CHAINS	3-20	Fig. 5 - Ammeter Group	7-7
FLAT PROPELLING BELT	3-20	Fig. 6 - Grille Kit	7-8
TO CHECK AND ADJUST FLAT		Fig. 7 - Cord Kit	7-9
PROPELLING BELT	3-20	Fig. 8 - Documentation Group	7-10
TO REPLACE FLAT PROPELLING		CROSS REFERENCE	8-1
BELT	3-20	PART NUMBER TO PAGE NUMBER	
MOTOR DRIVE BELT	3-21	CROSS REFERENCE LIST	8-2
TO CHECK AND ADJUST		PART DESCRIPTION TO PAGE NUMBER	
MOTOR DRIVE BELT	3-21	CROSS REFERENCE LIST	8-4
TO REPLACE MOTOR DRIVE			
BELT	3-22		
BRUSH DRIVE BELT	3-23		
TO REPLACE BRUSH DRIVE			
BELT	3-23		
SIDE BRUSH DRIVE BELT	3-24		
TO ADJUST SIDE BRUSH			
DRIVE BELT	3-24		
TO REPLACE SIDE BRUSH			
DRIVE BELT	3-24		
STATIC DRAG CHAIN	3-24		
PUSHING AND TRANSPORTING THE			
MACHINE	3-25		
PUSHING THE MACHINE	3-25		
TRANSPORTING THE MACHINE ..	3-25		
APPENDIX	4-1		
HARDWARE INFORMATION	4-3		
STANDARD BOLT TORQUE CHART	4-3		
METRIC BOLT TORQUE CHART ..	4-3		
BOLT IDENTIFICATION	4-3		
THREAD SEALANT AND LOCKING			
COMPOUNDS	4-3		
HOW TO USE THIS MANUAL	5-1		
IMPORTANT INFORMATION	5-1		
FINDING A TENNANT PART NUMBER	5-2		
PLACING AN ORDER	5-3		
STANDARD MODEL PARTS	6-1		
Fig. 1 - Recommended General			
Maintenance Items	6-3		
Fig. 2 - Replacement Brushes	6-6		
Fig. 3 - Main Frame and Charger			
Group	6-6		
Fig. 4 - Handle Group	6-8		
Fig. 5 - Hopper Assembly	6-9		
Fig. 6 - Brush Drive Group	6-10		
Fig. 7 - Motor and Wheel Drive Group .	6-12		
Fig. 8 - Filter Group	6-14		
Fig. 9 - Battery Group	6-16		
Fig. 10 - Wire Harnesses Group	6-18		
Fig. 11 - Vacuum Fan Group	6-20		
Fig. 12 - Label Kit	6-21		
OPTIONS	7-1		
Fig. 1 - Side Brush Group	7-2		
Fig. 2 - Lifting Bracket Kit	7-4		
Fig. 3 - Fine Particle Filter Kit	7-5		
Fig. 4 - Dual Carpet Lint Filter Kit	7-6		

SECTION 1

CONTENTS

	Page
MACHINE SPECIFICATIONS	1-3
POWER TYPE	1-3
POWER TRAIN	1-3
SUSPENSION SYSTEM	1-3
GENERAL MACHINE	
DIMENSIONS/CAPACITIES	1-3
MACHINE WEIGHTS	1-3
GENERAL MACHINE PERFORMANCE	1-3
MACHINE DIMENSIONS	1-4

MACHINE SPECIFICATIONS**POWER TYPE**

Electric motor - Nominal voltage 24 VDC,
0.75 hp (0.56 kw) @ 2175 rpm, 29 A
Batteries (2) - 12 V, 530 CCA, 105Ah
Battery charger - 24 VDC, 15 A output
115 VAC input
Battery charger - 24 VDC, 15 A, 115/230 VAC

MACHINE WEIGHTS

GVWR - 435 lb (197 kg)
Standard net weight, dry - 310 lb (141 kg)

GENERAL MACHINE PERFORMANCE

Maximum travel speed - 3 mph (4.8 km/h)
Turning radius - 56 in (1420 mm)

POWER TRAIN

Propelling - belt driven
Main brush - belt driven
Side brush option - belt driven

SUSPENSION SYSTEM

Front (2) - 4 x 1.37 caster wheels
Rear - 8 x 2 solid tire

**GENERAL MACHINE
DIMENSIONS/CAPACITIES**

Length - 52 in (1320 mm)
Length with side brush - 62 in (1575 mm)

Width - 32 in (815 mm)
Width with side brush - 34.5 in (880 mm)

Height - 40.25 in (1020 mm)
Track - 29.75 in (755 mm)
Wheelbase - 26.5 in (675 mm)

Main brush diameter - 8 in (205 mm)
Main brush length - 28.6 in (725 mm)
Side brush diameter - 16 in (405 mm)

Sweeping path width - 29 in (735 mm)
Sweeping path width with side brush - 37 in
(940 mm)

Hopper capacity - 2.6 cu ft (0.07 m³)
Dust filter area - 49 sq ft (4.5 m²)

MACHINE DIMENSIONS

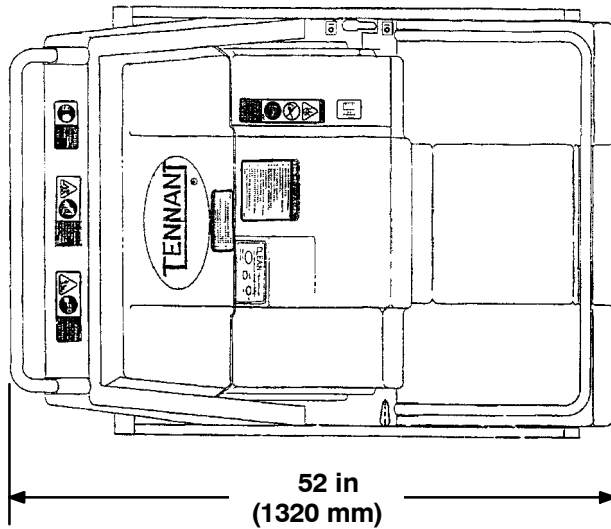

TOP VIEW

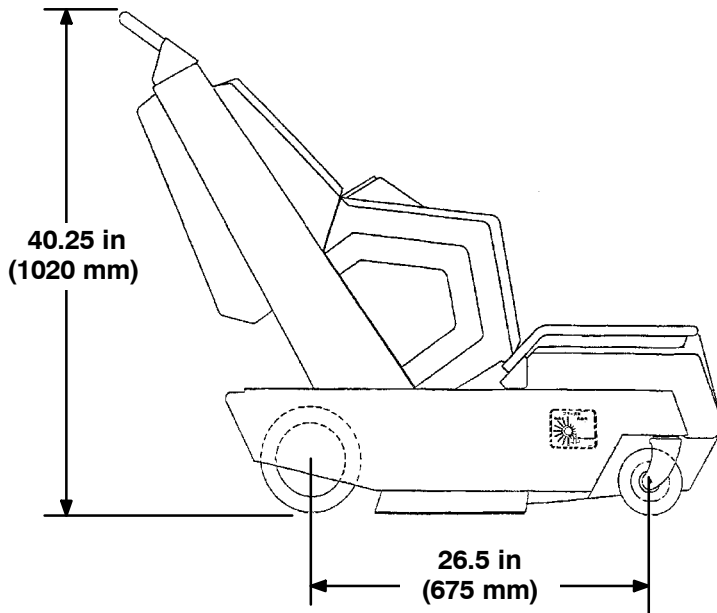

SIDE VIEW

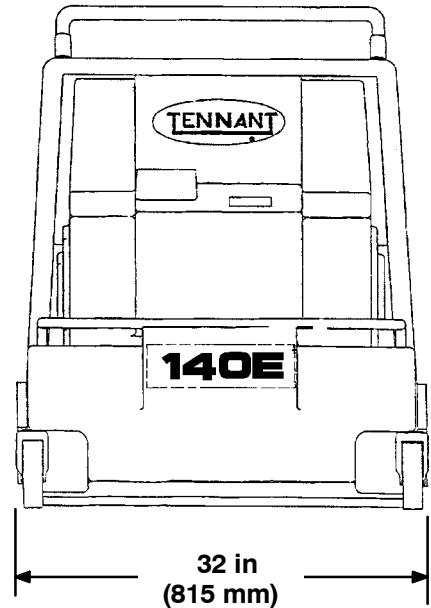

FRONT VIEW

CONTENTS

	Page
PREPARATION FOR OPERATION	2-3
OPERATION OF CONTROLS	2-4
MACHINE COMPONENTS	2-4
CLUTCH CONTROL HANDLE	2-5
MAIN BRUSH LIFT HANDLE	2-5
SIDE BRUSH	2-5
MAIN BRUSH REMOVAL LEVER	2-5
BATTERY COVER	2-6
MASTER POWER SWITCH	2-6
SHAKER RESET PUSHBUTTON	2-6
CLEAN FILTER PUSHBUTTON	2-6
MACHINE CIRCUIT BREAKER	2-6
CHARGER TIMER SWITCH	2-7
CHARGER PANEL	2-7
HOUR METER	2-7
CHARGING RATE GAUGE	2-7
MACHINE OPERATION	2-8
NORMAL SWEEPING OPERATION ...	2-8
PRE-START CHECKLIST	2-8
TO START MACHINE	2-8
TO SWEEP	2-8
TO DUMP HOPPER	2-9
POST OPERATION CHECKLIST -	
MOTOR OPERATING	2-9
TO STOP MACHINE	2-9
POST OPERATION CHECKLIST -	
MOTOR STOPPED	2-9
MACHINE TROUBLESHOOTING	2-10
MACHINE STORAGE	2-11
STORING MACHINE	2-11

PREPARATION FOR OPERATION

After uncrating and before operating the machine:

1. Check the machine for shipping damage. Report any damage to the carrier at once.
2. Read this manual carefully before operating or servicing this machine.

FOR SAFETY: Do Not Operate Machine, Unless Operation Manual Is Read And Understood.

3. Install the batteries and battery cables if not already done:
 - A. Place the batteries in the machine with the positive (+) posts toward the front of the machine.

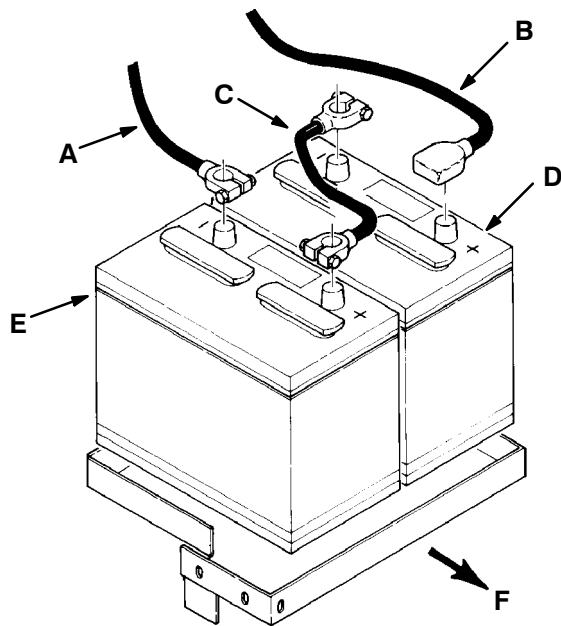

BATTERY CABLE CONNECTIONS

00099

- A. Cable "4"
- B. Cable "3"
- C. Cable "1"
- D. Brush Lift Lever Side Battery
- E. Vacuum Fan Side Battery
- F. Front of Machine

- B. Connect the cable labeled "1" between the positive (+) post on the vacuum fan side battery and the negative (-) post on the brush lift lever side battery.

- C. Connect the cable labeled "3" to the positive (+) post of the brush lift lever side battery.
- D. Connect the cable labeled "4" to the negative (-) post of the vacuum fan side battery.

4. Check the state of charge of the batteries as described in *BATTERIES* in the *MAINTENANCE* section. Charge the batteries if necessary.



WARNING: Batteries Emit Hydrogen Gas. Explosion Or Fire Can Result. Keep Sparks And Open Flame Away. Keep Covers Open When Charging.

5. Install the brushes as described in *BRUSHES* in the *MAINTENANCE* section.
6. Connect the batteries-to-machine connector.

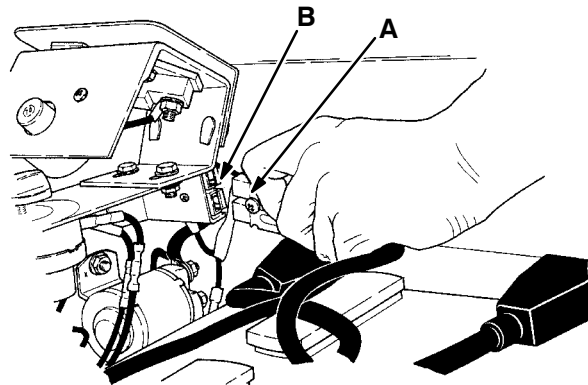

CONNECTING BATTERIES-TO-MACHINE CONNECTOR

02669

- A. Batteries Connector
- B. Machine Connector

7. Check the brush pattern(s) as described in *BRUSHES* in the *MAINTENANCE* section.

OPERATION OF CONTROLS

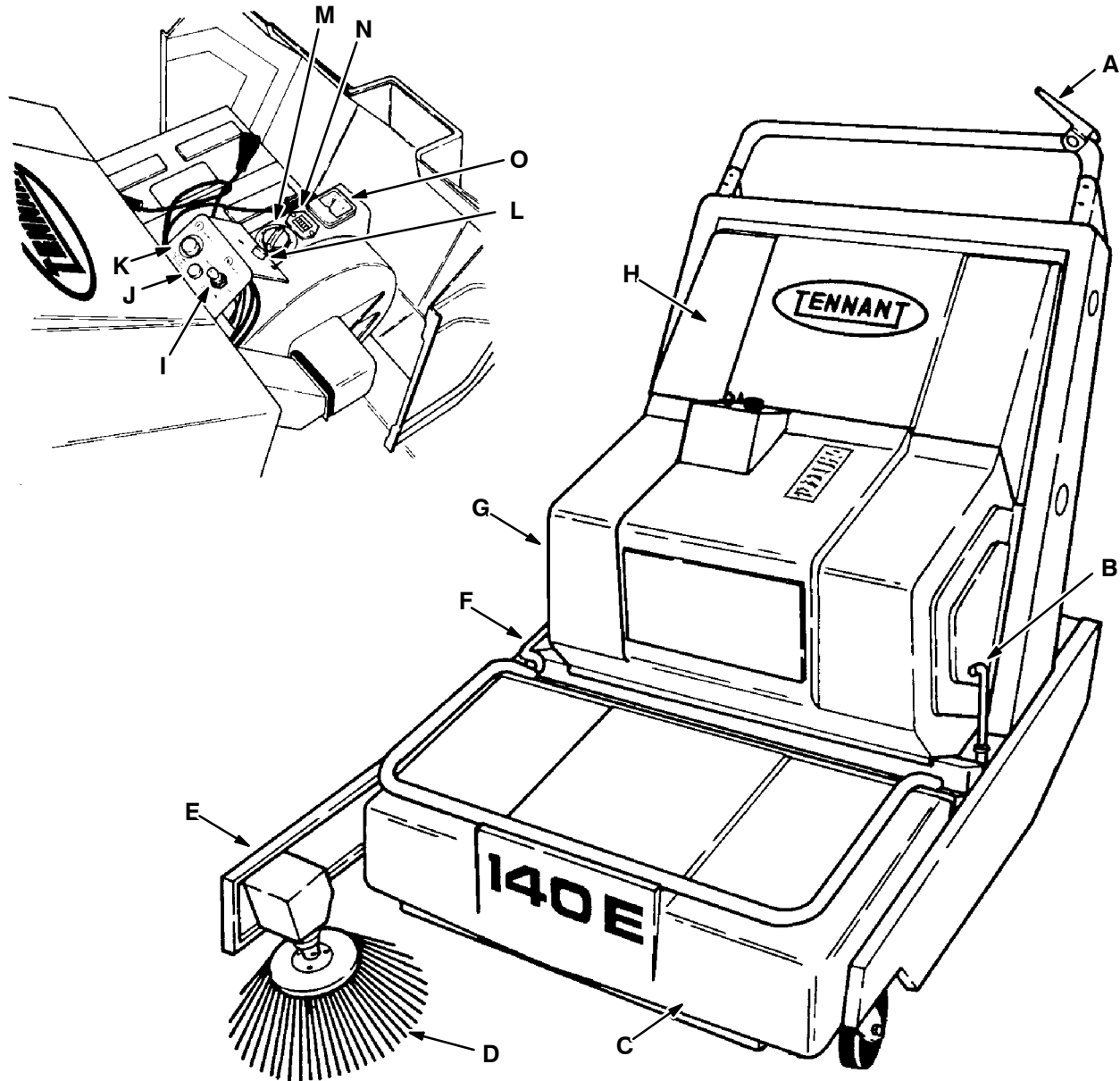

MACHINE COMPONENTS

- | | |
|-----------------------------|---------------------------------|
| A. Clutch Control Handle | I. Master Power Switch |
| B. Main Brush Lift Handle | J. Shaker Reset Pushbutton |
| C. Hopper | K. Clean Filter Pushbutton |
| D. Side Brush | L. Machine Circuit Breaker |
| E. Side Brush Arm | M. Charger Timer Switch |
| F. Main Brush Removal Lever | N. Hour Meter |
| G. Battery Cover | O. Charging Rate Gauge (Option) |
| H. Dust Filter Enclosure | |

02666
01189

CLUTCH CONTROL HANDLE

The clutch control handle operates a cable which controls the drive belt idler. To propel the machine forward, press the control handle – engaging the drive belt. To stop the machine, release the control handle – disengaging the drive belt.

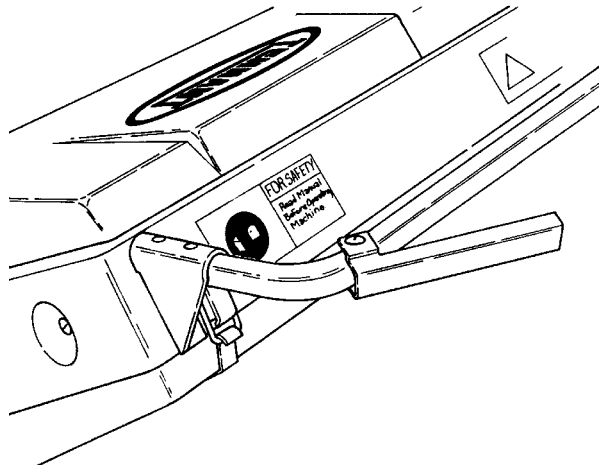

CLUTCH CONTROL HANDLE

06249

MAIN BRUSH LIFT HANDLE

The main brush lift handle operates a linkage which controls the height of the main brush.

To lower the main brush, pull the handle up, back, and release into the “lower” position.

To raise the main brush, pull the handle up and forward into the “raise” position.

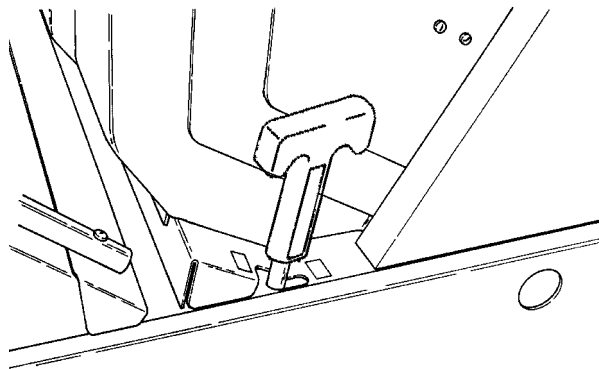

MAIN BRUSH LIFT HANDLE

01192

SIDE BRUSH

The side brush option gives the machine the added flexibility of sweeping along walls and under edges of tables, desks, etc. It is belt driven. To lower the side brush and start brush rotation, pull the side brush arm up, forward and down into the “operating” position – this engages the drive belt.

To raise the side brush and stop rotation, pull the side brush arm up and back into the “raised” position – this disengages the drive belt.

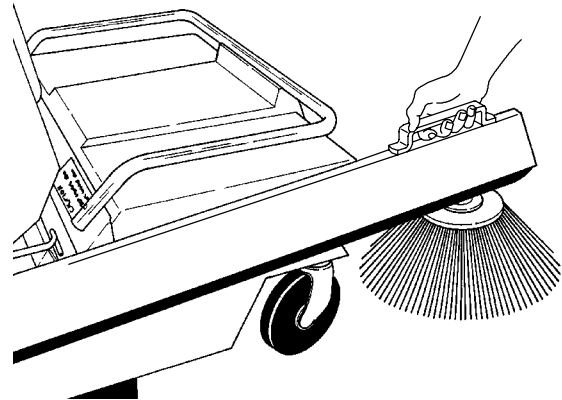

RAISING SIDE BRUSH

01195

MAIN BRUSH REMOVAL LEVER

The main brush removal lever controls the main brush spring arm idler plug position. The spring arm secures the main brush in the idler plug. To remove the main brush, lift and pull the lever away from the machine. This disengages the main brush idler plug from the main brush.

To install and secure the main brush in the machine, align the brush slots and idler keys and swing the lever toward the machine, locking it on the machine frame. See *MAIN BRUSH* in the *MAINTENANCE* section.

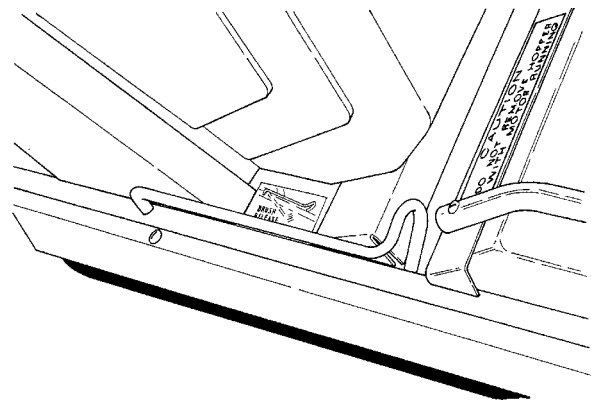

MAIN BRUSH REMOVAL LEVER

01193

OPERATION

BATTERY COVER

The battery cover covers the batteries and other electrical components. To tilt the battery cover forward, push the sides of the cover in. To remove or reinstall the battery cover, first remove the hopper. The front of the battery cover has hooks which are inserted in slots in the machine frame. Always have the battery cover in place when operating the machine. Always open the battery cover when charging the machine batteries.



WARNING: Batteries Emit Hydrogen Gas. Explosion Or Fire Can Result. Keep Sparks And Open Flame Away. Keep Covers Open When Charging.

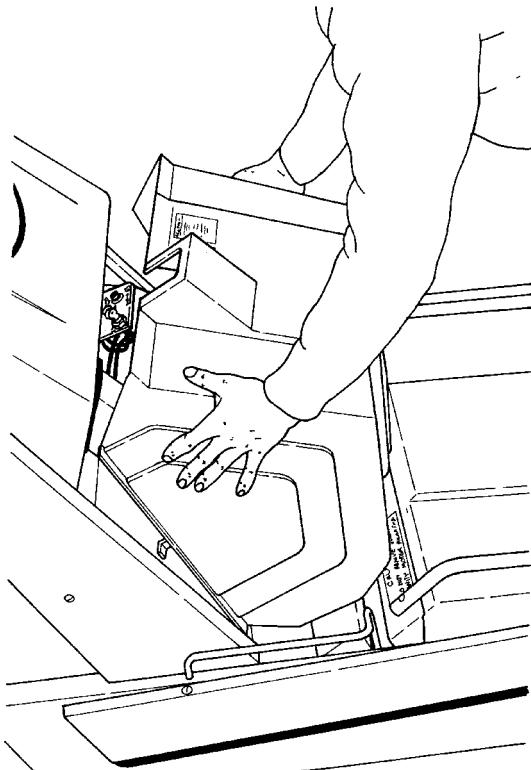

REMOVING BATTERY COVER

01194

MASTER POWER SWITCH

The master power switch controls the machine motor. To start the motor, turn the key clockwise into the "on" position. To stop the motor turn the key counterclockwise into the "off" position. Do not leave the machine unattended when the motor is operating.



WARNING: Machine Moves When Motor Is Running. Stop Motor Before Leaving Machine.

SHAKER RESET PUSHBUTTON

The shaker reset pushbutton provides shaker motor electrical overload protection. It is a 15 A circuit breaker. In the event of a circuit overload, the circuit breaker will trip. To reset the circuit breaker, push the reset pushbutton. If the overload which caused the circuit breaker to trip is still present in the circuit, the circuit breaker will continue to stop current flow until the overload is corrected.

CLEAN FILTER PUSHBUTTON

The clean filter pushbutton controls the dust filter shaker motor.

To shake and clean the dust filter with the shaker motor, push the button in for 15 seconds. To stop the shaker motor, release the pushbutton.

MACHINE CIRCUIT BREAKER

The machine circuit breaker provides the machine electrical overload protection, excluding the filter shaker motor. It is a 50 A circuit breaker. In the event of a circuit overload, the circuit breaker will trip. To reset the circuit breaker, push the reset button in. If the overload which caused the circuit breaker to trip is still present in the circuit, the circuit breaker will continue to stop current flow until the overload is corrected.

CHARGER TIMER SWITCH

The charger timer switch controls the battery charger on machines below serial number 009737. To start the battery charger, open the battery cover, then plug the battery charger into an appropriate voltage wall outlet, then turn the switch knob to the desired number of hours you wish to charge the batteries. The timer will automatically shut off the charger after the time has elapsed.

! WARNING: Batteries Emit Hydrogen Gas. Explosion Or Fire Can Result. Keep Sparks And Open Flame Away. Keep Covers Open When Charging.

CHARGER PANEL

The charger panel indicates battery charging status on machines serial number 009737 and above. The panel is located next to the vacuum fan housing. The panel shows the status of charging after the charger has been plugged into a wall outlet.

The panel also has an interrupt switch to be used if the charging cycle needs to be stopped.

*NOTE: If the charge cycle has to be stopped, press the interrupt switch **while** unplugging the charger.*

HOUR METER

The hour meter records the number of hours the machine has been operated. This information is useful in determining when to service the machine.

CHARGING RATE GAUGE

The charging rate gauge indicates the rate of charge being accepted by the batteries. The batteries are charged when the gauge needle is in the black "CHD" area. The batteries are still being charged when the gauge needle is in the green "normal charging" area.

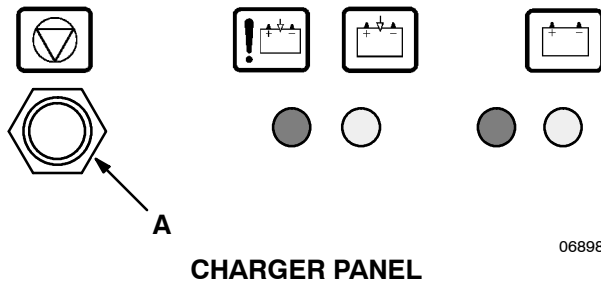

CHARGER PANEL

06898

A. Interrupt Switch

MACHINE OPERATION

NORMAL SWEEPING OPERATION

A normal sweeping operation consists of seven typical operations: pre-start checklist, starting machine, sweeping, dumping hopper, post operation checklist – motor operating, stopping machine, and post operation checklist – motor stopped.

THE PRE-START CHECKLIST lists things to check before starting the machine.

TO START MACHINE lists the steps required to start the machine.

TO SWEEP lists things to keep in mind before and during the sweeping operation.

TO DUMP HOPPER lists the steps required to dump the hopper.

POST OPERATION CHECKLIST – Motor Operating lists things to check before stopping the machine motor.

TO STOP MACHINE lists the steps required to stop the machine.

POST OPERATION CHECKLIST – Motor Stopped lists things to check after stopping the machine motor.

PRE-START CHECKLIST

Check under machine for leak spots.

Check battery charge level.

Check controls for proper operation.

Check service records to determine service requirements.

FOR SAFETY: Before Starting Machine, Make Sure All Safety Devices Are In Place And Operate Properly.

TO START MACHINE

NOTE: Before starting machine, perform the pre-start checks.

1. Place the master power switch in the “on” position.
2. Drive the machine to the area to be cleaned.

TO SWEEP

Plan the sweeping in advance. Try to arrange long runs with minimum stopping and starting. Sweep debris from very narrow aisles into main aisles ahead of time. Do an entire floor or section at one time. Overlap brush paths.

Pick up oversize debris before sweeping. Flatten or remove bulky cartons from aisles before sweeping. Pick up pieces of wire, twine, string, etc., which could become entangled in brush or brush plugs.

Press the clutch handle to place the machine in motion. Release the clutch handle for easier turning. Sweep as straight a path as possible. Avoid bumping into posts or scraping the sides of the sweeper. Empty the debris hopper when it becomes full.

1. Place the main brush lift handle in the “lower” position.
2. Pull the side brush arm up, forward and down into the “operating” position if present.
3. Sweep as required.

NOTE: Do not allow the machine to remain stationary with machine operating and the main brush in the “lower” position as it may cause wear marks on the floor.

TO DUMP HOPPER

1. Stop the motor.



WARNING: Brush Throws Debris. Stop Motor Before Lifting Hopper.

2. Grasp the hopper handles with both hands.
3. Lift and swing the hopper upward to remove the hopper from the machine.

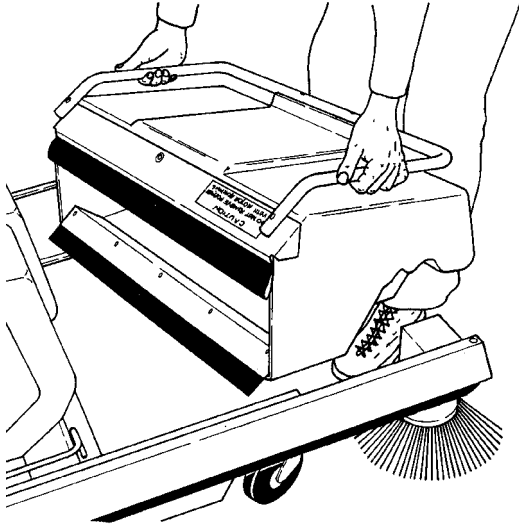

REMOVING HOPPER

01196

4. Dump the debris out of the hopper into suitable refuse container.
5. Tip the hopper down and slide it into place on the machine.

POST OPERATION CHECKLIST - MOTOR OPERATING

Check brush patterns for width and evenness.

TO STOP MACHINE

1. When finished sweeping, place the main brush lift handle and the side brush arm in the "raise" position.

FOR SAFETY: Before Leaving Or Servicing Machine; Stop On Level Surface, And Turn Off Machine And Remove Key.

2. Stop the motor.

POST OPERATION CHECKLIST - MOTOR STOPPED

Check the batteries state of charge. Charge if needed.

Check skirts for damage, wear, and adjustment.

Check for wire or string tangled on brushes.

OPERATION

MACHINE TROUBLESHOOTING

Problem	Cause	Remedy
Poor sweeping performance	Main brush worn out	Replace main brush
	Main Brush not properly adjusted	Adjust main brush lift handle to obtain correct brush pattern
	Main Brush not level with floor	Adjust brush pattern
	Hopper full	Empty hopper
	Dust filter clogged	Remove and clean dust filter
	Brush jammed with debris	Remove debris
	Hopper lip or dust skirt not properly adjusted	Adjust hopper lip or dust skirt
	Brush drive belts slipping or broken	Adjust or replace belts
Dusting	Dust filter clogged	Remove and clean filter
	Filter not seated correctly against its seals	Remove and re-install filter
	Dust filter damaged	Replace dust filter
	Hopper full	Empty hopper
	Clogged ducts	Clean ducts
	Ducts not engaging seals or seals damaged	Adjust or replace seals
	Dust skirts not properly adjusted or are damaged	Adjust or replace dust skirts
	Vacuum fan not operating	Fan drive sheave or impeller key is broken. Check drive belt
Brush pattern not even	Main brush not lowering evenly due to debris jam	Remove main brush and debris
	Bail arm not level	Adjust arm position
	Main brush spring arm may be out of adjustment	Adjust arm position
	Main brush not seated correctly on drive cups	Remove and re-install main brush
Machine will not travel	Flat belt broken	Replace belt
	Oil on flat belt or shaft	Clean belt and sheaves
	Clutch shaft arm loose or out of adjustment	Adjust arm
	Clutch cable broken or out of adjustment	Replace or adjust cable
	Rear drive wheel jammed	Free wheel
	Motor drive belt broken or slipping	Replace or adjust belt
Excessive belt wear or breakage	Belt is over-tensioned or under-tensioned, causing slippage	Adjust belt tension
	Belt sheaves have moved out of adjustment	Align sheaves
	Belt or sheaves have dirt or oil on them	Clean sheaves and belt

MACHINE STORAGE

STORING MACHINE

When storing the machine for extended periods of time, the following procedures must be followed to lessen the chance of rust, sludge, and other deposits from forming:

1. Place the main brush, and side brush if so equipped, in the “raise” position.
2. Empty and clean the debris hopper.
3. Charge the machine batteries.
4. Disconnect the batteries-to-machine battery connector.

SECTION 3

CONTENTS

	Page		Page
RECOMMENDED FIRST 20-HOUR		BELTS AND CHAINS	3-20
MACHINE INSPECTION	3-3	FLAT PROPELLING BELT	3-20
MAINTENANCE CHART	3-4	TO CHECK AND ADJUST FLAT	
ELECTRICAL SYSTEM	3-6	PROPELLING BELT	3-20
BATTERIES	3-6	TO REPLACE FLAT PROPELLING	
BATTERY CHARGING	3-7	BELT	3-20
TO CHARGE BATTERIES (For machines		MOTOR DRIVE BELT	3-21
below serial number 009737)	3-7	TO CHECK AND ADJUST	
TO CHARGE BATTERIES (For machines		MOTOR DRIVE BELT	3-21
serial number 009737 and above) ..	3-8	TO REPLACE MOTOR DRIVE BELT	3-22
ELECTRICAL SCHEMATIC (For machines		BRUSH DRIVE BELT	3-23
below serial number 009737)	3-10	TO REPLACE BRUSH DRIVE BELT	3-23
ELECTRICAL SCHEMATIC (For machines		SIDE BRUSH DRIVE BELT	3-24
serial number 009737 and above) ...	3-11	TO ADJUST SIDE BRUSH DRIVE	
BRUSHES	3-12	BELT	3-24
MAIN BRUSH	3-12	TO REPLACE SIDE BRUSH	
TO REMOVE MAIN BRUSH	3-12	DRIVE BELT	3-24
TO INSTALL MAIN BRUSH	3-12	STATIC DRAG CHAIN	3-24
TO CHECK AND ADJUST MAIN		PUSHING AND TRANSPORTING THE	
BRUSH PATTERN	3-13	MACHINE	3-25
SIDE BRUSH	3-14	PUSHING THE MACHINE	3-25
TO REMOVE SIDE BRUSH	3-14	TRANSPORTING THE MACHINE	3-25
TO INSTALL SIDE BRUSH	3-14		
TO ADJUST SIDE BRUSH	3-14		
DEBRIS HOPPER AND DUST FILTER ...	3-15		
DEBRIS HOPPER	3-15		
TO EMPTY HOPPER	3-15		
TO ADJUST HOPPER FLOOR			
CLEARANCE	3-15		
REAR GUIDE WHEELS	3-16		
TO ADJUST REAR GUIDE WHEELS	3-16		
HOPPER DUST FILTER	3-16		
TO REMOVE DUST FILTER	3-17		
TO INSTALL DUST FILTER	3-17		
SKIRTS AND SEALS	3-18		
SIDE DUST SKIRTS	3-18		
TO ADJUST SIDE DUST SKIRTS ..	3-18		
TO REPLACE SIDE DUST SKIRTS .	3-18		
HOPPER SIDE SEALS	3-19		
TO REPLACE HOPPER SIDE			
SEALS	3-19		
REAR BRUSH SKIRT	3-19		
TO REPLACE REAR BRUSH SKIRT	3-19		

RECOMMENDED FIRST 20-HOUR MACHINE INSPECTION

After the first 20 hours of operation, perform the following procedures:

1. Check the specific gravity of the batteries.
2. Check the battery cable connections.
3. Check the floor skirts to floor clearance.
4. Check the main brush and side brush, if so equipped, brush patterns.

MAINTENANCE CHART

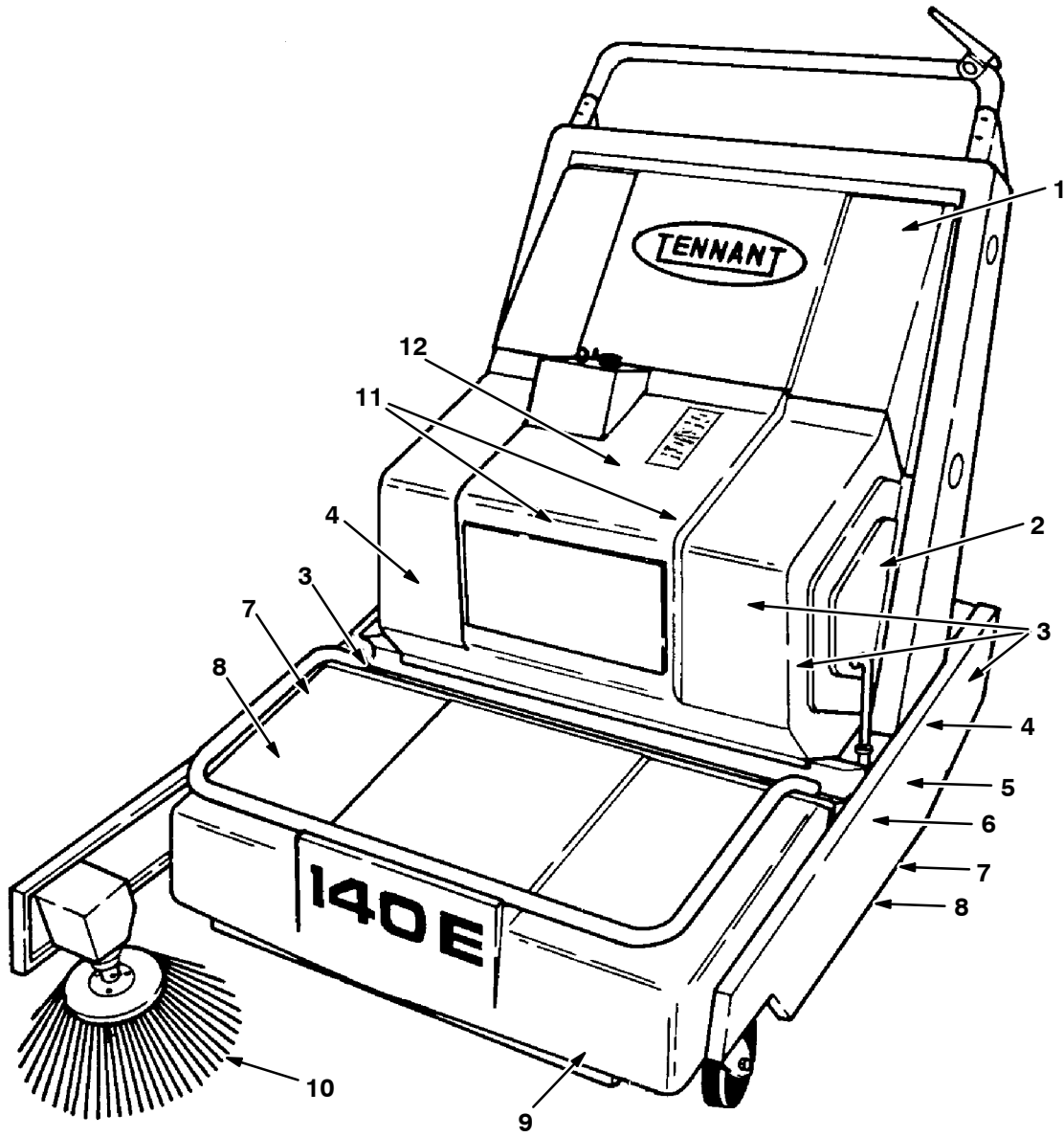

01189

Interval	Key	Description	Procedure	Lubricant/ Fluid	No. of Service Points
Daily	11	Batteries	Check electrolyte level	-	2
	6	Main brush	Check for wear or damage	-	1
	10	Side brush	Check for wear or damage	-	1
	1	Dust filter	Shake clean	-	1
20 Hours or Weekly	11	Batteries	Check specific gravity	-	2
	12	Battery cables	Check for loose or corroded connections	-	3
	6	Main brush	Rotate end-or-end and check brush pattern	-	1
	10	Side brush	Check brush pattern	-	1
80 Hours or 4 Weeks	11	Batteries	Clean battery tops	-	2
	9	Debris hopper	Check floor clearance adjustment	-	1
	1	Dust filter	Clean	-	1
	7	Side dust skirts	Check for wear or damage and adjustment	-	2
	8	Hopper side seals	Check for wear or damage	-	2
	5	Rear brush skirt	Check for wear or damage	-	1
160 Hours or 8 Weeks	3	Drive belts	Check for wear or damage and adjustment	-	1
	2	Static drag chain	Check for wear and floor contact	-	1
	4	Rear guide wheels	Check floor clearance adjustment	-	2

ELECTRICAL SYSTEM

BATTERIES

The two 12-volt machine batteries provide all of the energy used by the machine. The standard batteries are rated at 530 CCA. They require regular maintenance to keep them operating their best.

Do not allow batteries to remain in discharged condition for any length of time. Do not operate machine if batteries are in poor condition or discharged beyond 75%, specific gravity below 1.170.

Check the battery cables for loose connections on the battery terminals daily. Inspect the cables for corrosion or damage.

Clean the top surface and the terminals of the batteries after every 80 hours of operation. Use a strong solution of baking soda and water. Brush the solution sparingly over the battery top, terminals, and cable clamps. Do not allow any baking soda solution to enter the battery. Use a wire brush to clean the terminal posts and the cable connectors. After cleaning, apply a coating of clear petroleum jelly to the terminals and the cable connectors. Keep the tops of the batteries clean and dry.

Keep all metallic objects off the top of the batteries, as they may cause a short circuit. Replace worn or damaged wires.

Check the electrolyte level in each battery cell before and after charging, and after every 50 hours of operation. Do not charge the batteries unless the fluid is slightly above the battery plates. If needed, add just enough distilled water to cover the plates. Never add acid to the batteries. Do not overfill. Always keep the battery caps on, except when adding water or taking hydrometer readings.

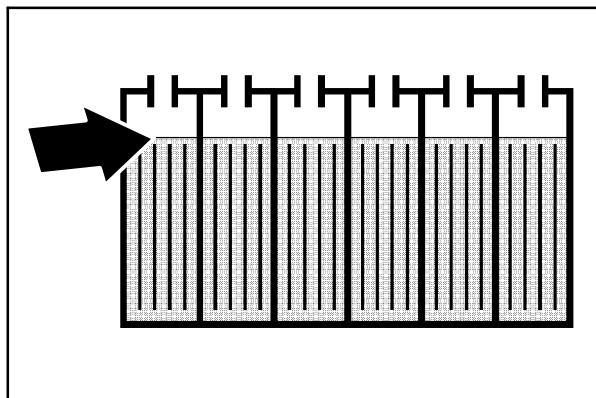

BATTERY ELECTROLYTE LEVEL

Use a hydrometer to check the electrolyte specific gravity after every 20 hours of operation.

If one or more battery cells tests lower than the other battery cells, (0.050 or more) the cell is damaged, shorted, or is about to fail.

NOTE: Do not take readings immediately after adding water - if the water and acid are not thoroughly mixed, the readings may not be accurate. Check the hydrometer readings against this chart:

SPECIFIC GRAVITY at 80° F (27° C)	BATTERY CONDITION
1.260 - 1.280	100% charged
1.230 - 1.250	75% charged
1.200 - 1.220	50% charged
1.170 - 1.190	25% charged
1.110 - 1.160	Discharged

NOTE: If the readings are taken when the battery electrolyte is any temperature other than 80° F (27° C), the reading must be temperature corrected.

To determine the corrected specific gravity reading when the temperature of the battery electrolyte is other than 80° F (27° C):

Add to the specific gravity reading 0.004, 4 points, for each 10° F (6° C) above 80° F (27° C).

Subtract from the specific gravity reading 0.004, 4 points for each 10° F (6° C) below 80° F (27° C).

BATTERY CHARGING

The machine batteries are specifically made for this machine application. They are unique in that they hold their power for long periods of time, but they can only be recharged a certain number of times. To get the most life from the batteries, charge them when 75% of the battery power has been used, so the battery specific gravity is between 1.190 and 1.170.

Do not charge the batteries for more than eight hours. If batteries are not fully discharged, reduce charging time proportionally.

Do not expose the battery charger to water. Do not touch uninsulated battery terminals or unnecessarily expose any portion of your body to the batteries when making electrical connections.

TO CHARGE BATTERIES (For machines below serial number 009737)

1. Stop the machine on a flat, dry surface next to an electrical outlet.
2. Turn off the master power switch.

FOR SAFETY: Before Leaving Or Servicing Machine; Stop On Level Surface, And Turn Off Machine And Remove Key.

3. Lift the battery cover into the "open" position.



WARNING: Batteries Emit Hydrogen Gas. Explosion Or Fire Can Result. Keep Sparks And Open Flame Away. Keep Covers Open When Charging.

4. Check the water level in the batteries.

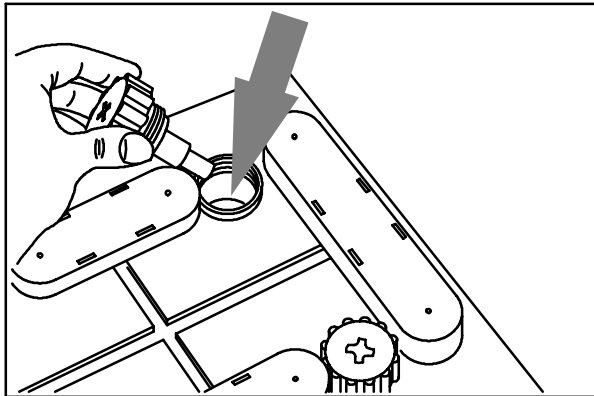

CHECK ELECTROLYTE LEVEL

08247

If the water level is low, add just enough distilled water to cover the plates. **DO NOT OVERFILL.** The battery can overflow during charging due to expansion.

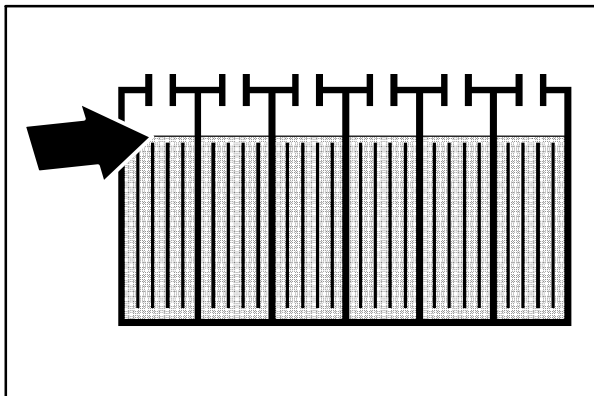

BATTERY ELECTROLYTE LEVEL

NOTE: Make sure the battery caps are in place while charging.

FOR SAFETY: When Servicing Machine, Avoid Contact With Battery Acid.

5. Turn the battery charger timer to the "off" position.
6. Plug the battery charger into an electrical outlet.
7. Turn the battery charger timer to the "start" position. The charging rate gauge will indicate the charger is operating.

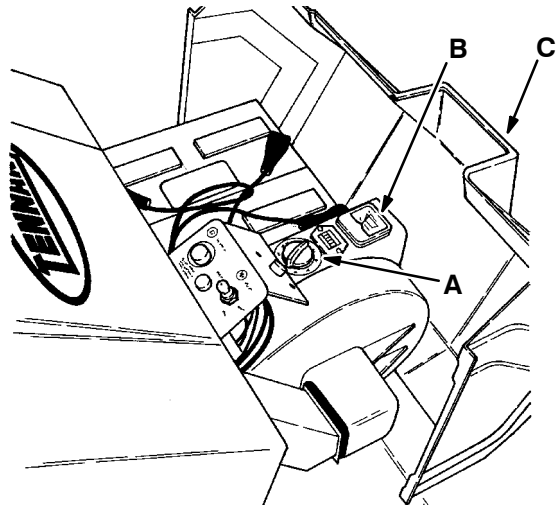

BATTERY CHARGER TIMER

02666

- A. Timer Knob**
- B. Charging Rate Gauge**
- C. Battery Cover**

8. The batteries will be fully charged when the timer reads "off" or the battery specific gravity is 1.28 to 1.26.
9. Turn the timer to "off" position.
10. Disconnect the battery charger from its power source.

NOTE: Make sure the battery charger has been turned off before unplugging the charger from the battery connector on the machine.

11. Check the electrolyte level in each battery cell after charging. If needed, add distilled water to raise the electrolyte level to about 12mm (0.4 in) below the bottom of the sight tubes.
12. Close the battery cover.

MAINTENANCE

TO CHARGE BATTERIES (For machines serial number 009737 and above)

1. Stop the machine on a flat, dry surface next to an electrical outlet.
2. Turn off the master power switch.

FOR SAFETY: Before Leaving Or Servicing Machine; Stop On Level Surface, And Turn Off Machine And Remove Key.

3. Lift the battery cover into the "open" position.



WARNING: Batteries Emit Hydrogen Gas. Explosion Or Fire Can Result. Keep Sparks And Open Flame Away. Keep Covers Open When Charging.

4. Check the water level in the batteries.

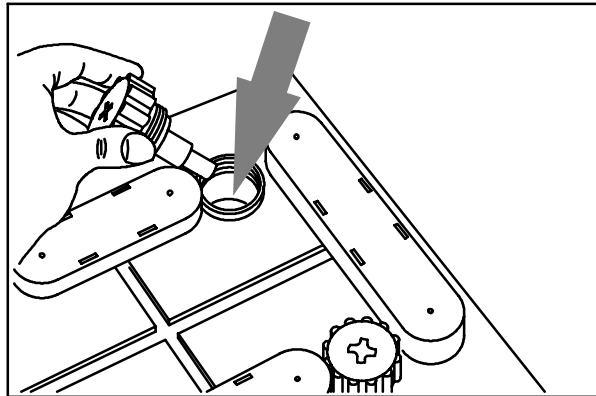

CHECK ELECTROLYTE LEVEL

08247

If the water level is low, add just enough distilled water to cover the plates. **DO NOT OVERFILL.** The battery can overflow during charging due to expansion.

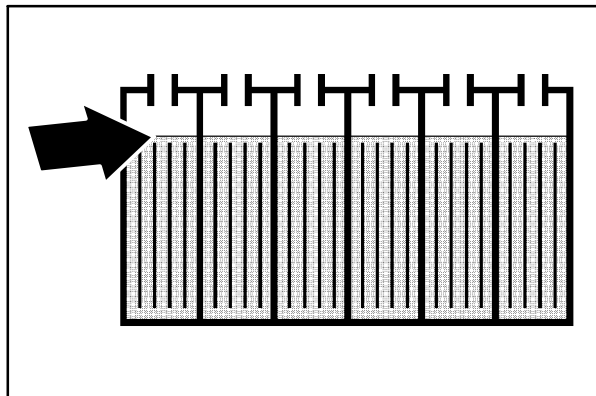

BATTERY ELECTROLYTE LEVEL

FOR SAFETY: When Servicing Machine, Avoid Contact With Battery Acid.

5. Plug the battery charger into an AC wall outlet. The charger will go through a self diagnostic check. All the indicator lamps on the charger panel will flash showing the diagnostic check is in progress.

NOTE: If the red no charge indicator lamp lights when the charger is plugged into a wall outlet, the charger can not charge the battery, meaning there is something wrong with the battery.

When the lamps stop flashing, the *red incomplete battery status indicator lamp* lights. After a short delay, the *yellow charger on indicator lamp* lights showing the charger has turned on.

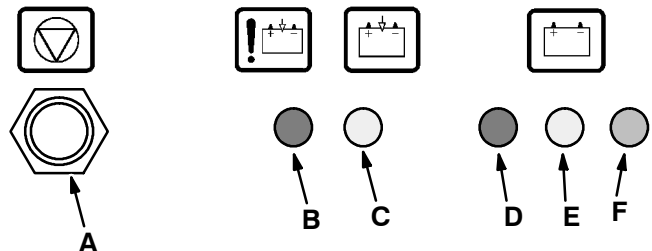

06898

CHARGER PANEL

- A. Interrupt Switch
- B. Red No Charge Indicator Lamp
- C. Yellow Charger On Indicator Lamp
- D. Red Incomplete Battery Status Indicator Lamp
- E. Yellow 80% Charge Indicator Lamp
- F. Green Complete Charge Indicator Lamp

As the battery charges, the *red incomplete battery status indicator lamp* goes out and the *yellow 80% charge indicator lamp* lights.

Finally the *yellow 80% charge indicator lamp* goes out and the green complete charge indicator lamp lights showing the battery is completely charged. After a short time, the *yellow charger on indicator lamp* goes out showing the charger has turned off.

The *green complete charge indicator lamp* will remain on until the charger is unplugged from the wall outlet.

*NOTE: If the charge cycle has to be stopped, press the interrupt switch **while** unplugging the charger from the wall outlet.*

6. Unplug the charger from the wall outlet.
7. Check the electrolyte level in each battery cell after charging. If needed, add distilled water to raise the electrolyte level to about 12mm (0.4 in) below the bottom of the sight tubes.
8. Close the battery cover.

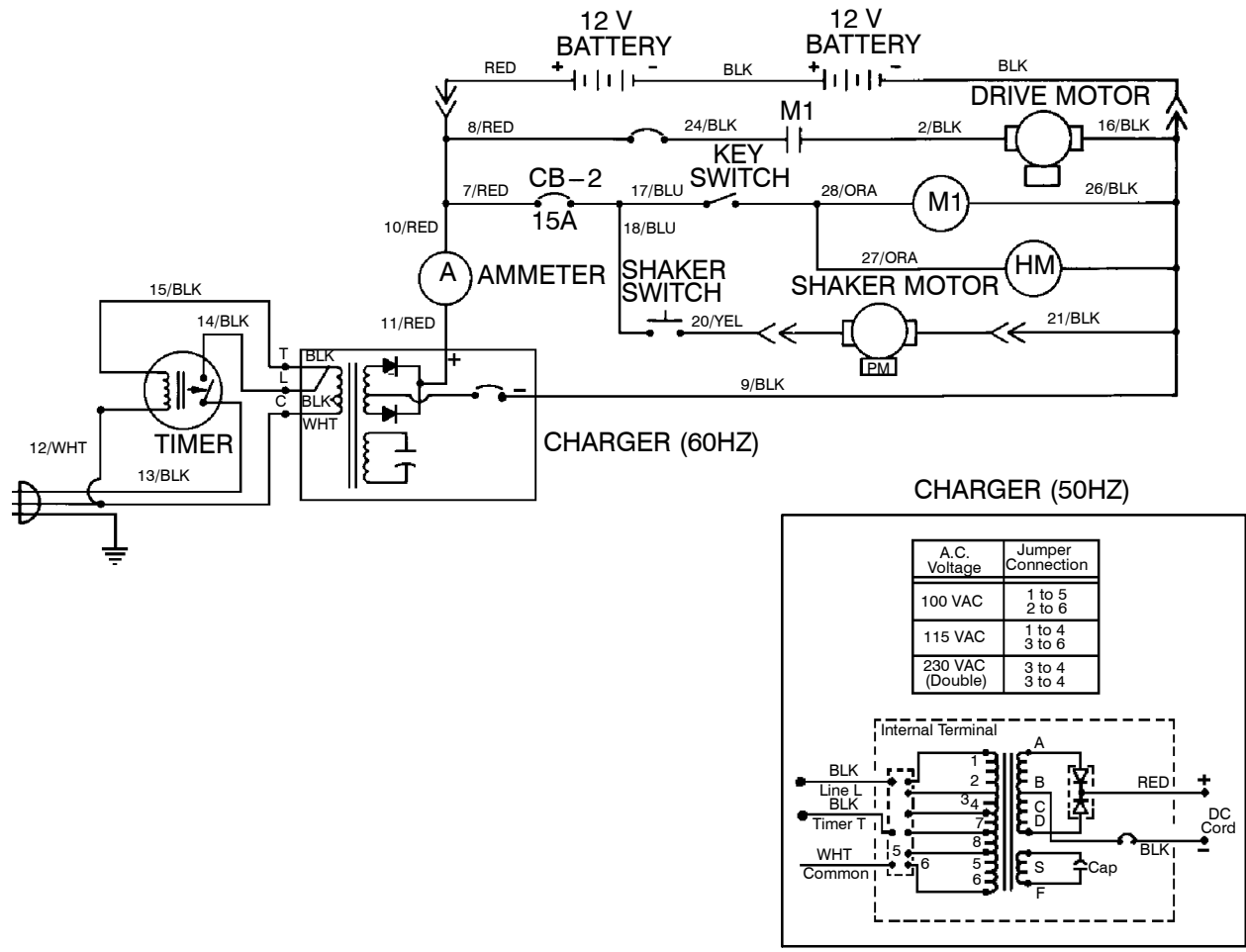

ELECTRICAL SCHEMATIC
(For machines below serial number 009737)

02649

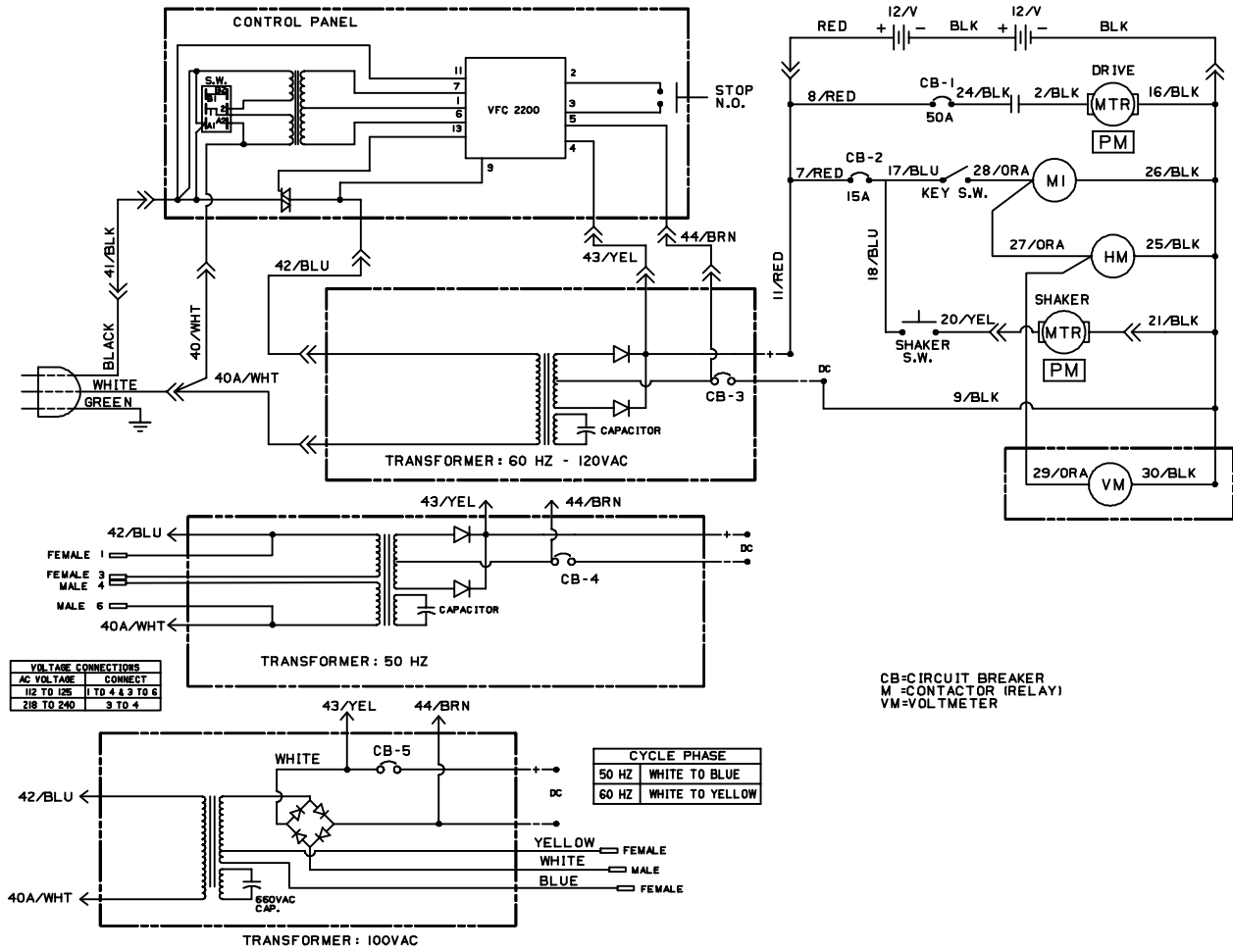

ELECTRICAL SCHEMATIC
 (For machines serial number 009737 and above)

06985

BRUSHES

MAIN BRUSH

The main brush is tubular and spans the width of the machine. It sweeps debris into the hopper. It should be inspected daily for wear or damage. Remove any string or wire found tangled on the main brush, main brush drive hub, or main brush idler hub.

The main brush pattern should be checked after every 20 hours of operation. The main brush pattern should be approximately 1.5 in (40 mm) wide when sweeping hard floors and 0.5 in (15 mm) when sweeping carpeted floors. Check the main brush pattern only on hard floors with the main brush in the lowered position. Main brush pattern adjustments are made by rotating the main brush lift handle. Use the carpet brush on carpets for better performance and brush life.

Rotate the brush after every 20 hours of operation for maximum brush life. The main brush should be replaced when the remaining brush bristle measures 1.25 in (30 mm).

TO REMOVE MAIN BRUSH

1. Place the master power switch in the "off" position.

FOR SAFETY: Before Leaving Or Servicing Machine; Stop On Level Surface, And Turn Off Machine And Remove Key.

2. Disconnect the batteries-to-machine connector.
3. Lift the hopper up and out of the machine.



WARNING: Brush Throws Debris. Stop Motor Before Lifting Hopper.

4. Pull the main brush removal lever away from the machine to disengage the main brush idler plug from the main brush.
5. Grasp the main brush and pull it off the main brush drive plug and out of the main brush compartment.

TO INSTALL MAIN BRUSH

1. Pull the main brush removal lever away from the machine.
2. Line up one of the slotted ends of the main brush with the drive plug drive keys.

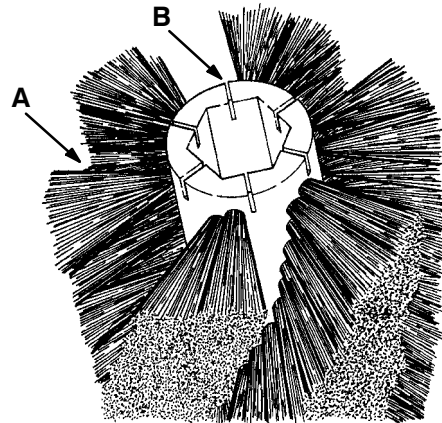

MAIN BRUSH DRIVE SLOTS

01207

- A. Main Brush
B. Drive Slot

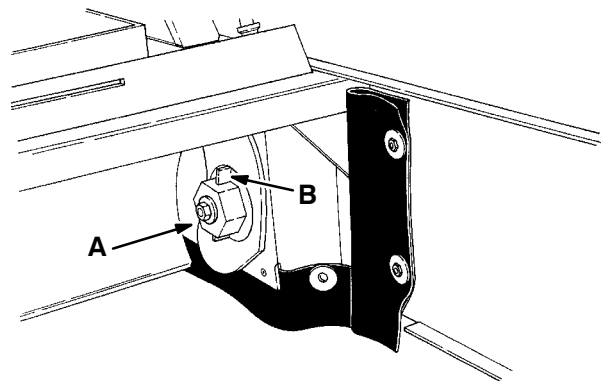

MAIN BRUSH DRIVE PLUG DRIVE KEYS

01208

- A. Drive Plug
B. Drive Key

3. Fit one end of the main brush over the main brush drive plug.

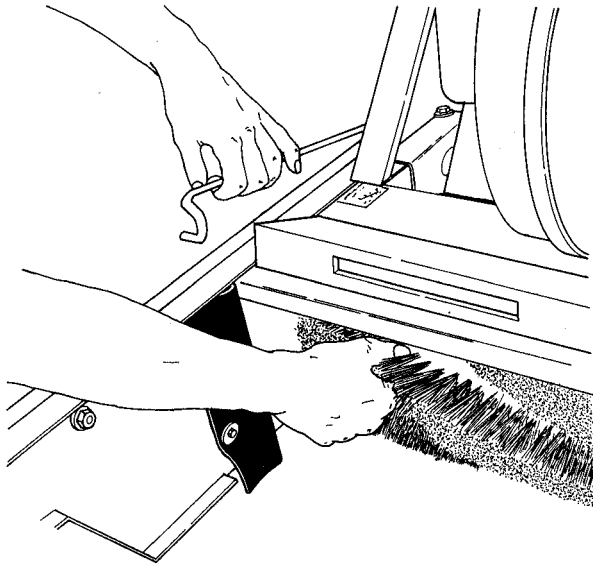

INSTALLING MAIN BRUSH

01209

4. Position the other end of the main brush over the main brush idler plug.
5. Push and lock the main brush removal lever into place on the machine frame to secure the main brush.
6. Check and adjust the main brush pattern as described in *TO CHECK AND ADJUST MAIN BRUSH PATTERN*.
7. Reconnect the batteries-to-machine connector.

TO CHECK AND ADJUST MAIN BRUSH PATTERN

1. Place the machine over a hard floor.
2. Place the master power switch in the “on” position.
3. Place the main brush lift handle in the “lower” position to lower the main brush to the floor for one minute while holding the machine in one place.
4. Pull the main brush lift handle up and forward to raise the main brush.
5. Move the machine away from the main brush polish mark.
6. Place the master power switch in the “off” position.

FOR SAFETY: Before Leaving Or Servicing Machine; Stop On Level Surface, And Turn Off Machine And Remove Key.

7. Observe the width of the polish mark. The proper polish width is 1.5 in (40 mm) for hard floors and 0.5 in (15 mm) for carpet floors.

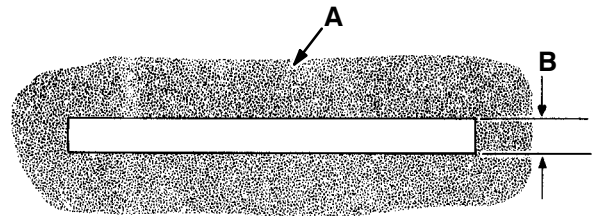

00582

MAIN BRUSH PATTERN

- A. Main Brush Pattern**
- B. Polish Width**

If the polish mark width is too wide, turn the main brush lift handle clockwise to raise the brush.

If the polish mark width is too narrow, turn the main brush lift handle counterclockwise to lower the brush.

If any adjustments are made, recheck the main brush pattern before resuming work with the machine.

SIDE BRUSH

The side brush sweeps debris from walls or curbs into the path of the main brush. It should be inspected daily for wear or damage. Remove any string or wire found tangled on the side brush or side brush drive hub.

The side brush adjustment should be checked after every 20 hours of operation. The side brush is properly adjusted when, with the side brush arm in the “raised” position, there is approximately 1 in (25 mm) of space between the floor and the side brush bristles.

Side brush adjustments are made by mounting the side brush in a different one of the five mounting holes in the side brush drive shaft.

The side brush should be replaced when the remaining brush bristle measures 1 in (25 mm) in length.

TO REMOVE SIDE BRUSH

1. Place the master power switch in the “off” position.

FOR SAFETY: Before Leaving Or Servicing Machine; Stop On Level Surface, And Turn Off Machine And Remove Key.

2. Pull the side brush arm up and back to raise the side brush.
3. Remove the side brush retaining bolt or hair cotter pin.

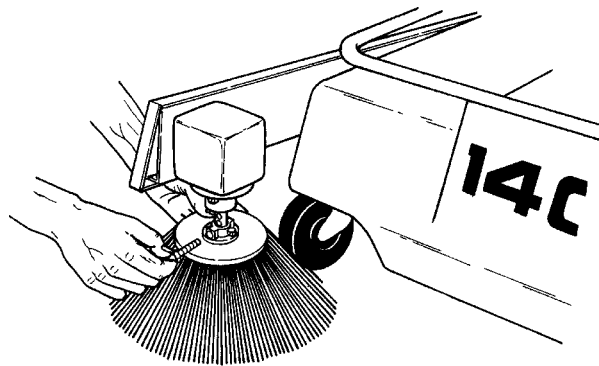

01027

REMOVING SIDE BRUSH RETAINING BOLT

4. Slide the side brush off the side brush drive shaft.

TO INSTALL SIDE BRUSH

1. Slide the side brush onto the side brush drive shaft.
2. Fasten the side brush to the shaft with the retaining bolt or hair cotter pin.
3. Check the side brush adjustment as described in *TO ADJUST SIDE BRUSH*.

TO ADJUST SIDE BRUSH

1. Place the master power switch in the “off” position.

FOR SAFETY: Before Leaving Or Servicing Machine; Stop On Level Surface, And Turn Off Machine And Remove Key.

2. Pull the side brush arm up and back to put the side brush in the “raised” position.
3. Remove the side brush retaining bolt or hair cotter pin.
4. Slide the side brush up or down on the shaft until there is approximately 1 in (25 mm) of space between the floor and the side brush bristles.

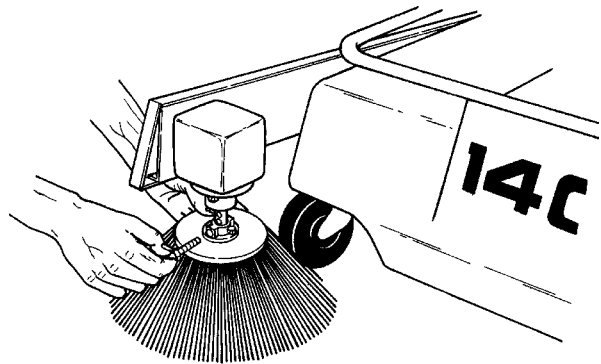

01027

ADJUSTING SIDE BRUSH HEIGHT

5. Line up the side brush and drive shaft holes to allow the side brush to be nearest to the specified dimension.
6. Secure the side brush to the drive shaft with the retaining bolt or hair cotter pin.

DEBRIS HOPPER AND DUST FILTER

DEBRIS HOPPER

The debris hopper collects debris swept up by the main brush. It should be emptied after every work shift.

The hopper floor clearance should be checked and adjusted, if necessary, after every 80 hours of operation.

TO EMPTY HOPPER

1. Place the master power switch in the "off" position.



WARNING: Brush Throws Debris. Stop Motor Before Lifting Hopper.

2. Grasp the hopper handles with both hands.
3. Lift and swing the hopper upward to remove the hopper from the machine.

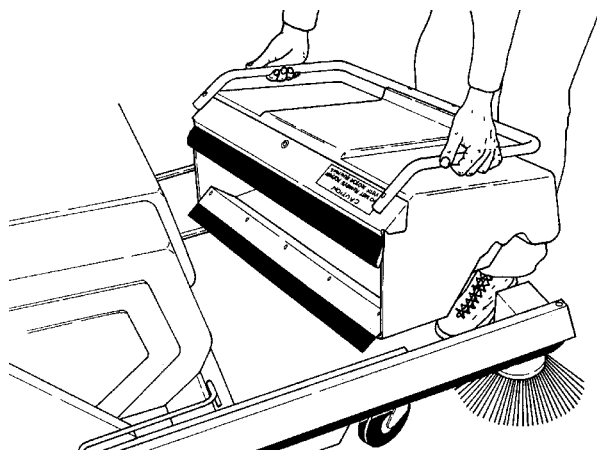

REMOVING HOPPER

01196

4. Dump the debris out of the hopper into suitable refuse container.
5. Tip the hopper down and slide it into place on the machine.

TO ADJUST HOPPER FLOOR CLEARANCE

1. Empty the hopper
2. Stop the machine on a smooth level floor.
3. Place the master power switch in the "off" position.

FOR SAFETY: Before Leaving Or Servicing Machine; Stop On Level Surface, And Turn Off Machine And Remove Key.

4. Loosen the three hopper top seal retainer bolts on the hopper.

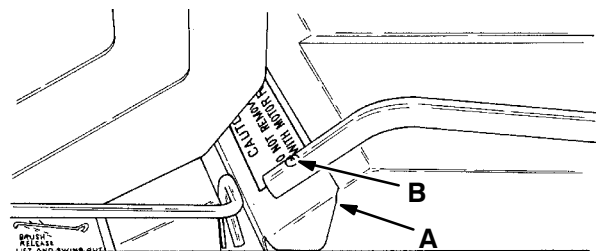

01210

HOPPER TOP SEAL RETAINER

- A. Hopper Top Seal Retainer**
- B. Retainer Bolt**

5. Place two 0.38 to 0.5 in (10 to 15 mm) blocks on the floor under the hopper wear plate.
6. Slide the hopper top seal retainer up or down so that the retainer just touches the machine frame.
7. Tighten the hopper top seal retainer bolts.
8. Remove the blocks from under the hopper wear plate.

REAR GUIDE WHEELS

The rear guide wheels prevent the rear of the machine from tipping. They are located just behind the main brush shroud. Check the floor clearance after every 160 hours of operation. They should clear the floor by 0.38 in (10 mm).

TO ADJUST REAR GUIDE WHEELS

1. Place the master power switch in the "off" position.

FOR SAFETY: Before Leaving Or Servicing Machine; Stop On Level Surface, And Turn Off Machine And Remove Key.

2. Loosen the two bolts holding each of the rear guide wheels in place.
3. Slide the guide wheels up or down so that they clear the floor by 0.38 in (10 mm).

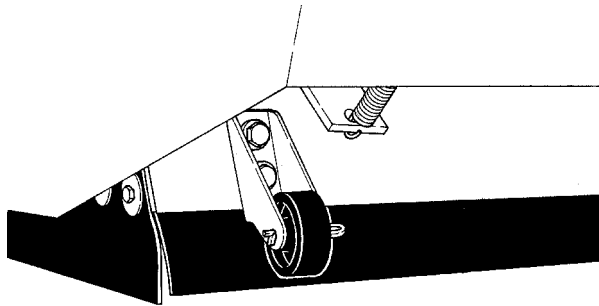

REAR GUIDE WHEEL

01211

4. Tighten the two bolts on each guide wheel.

HOPPER DUST FILTER

The hopper dust filter is located inside the dust filter compartment. The dust filter filters the air which is drawn up from the main brush compartment. Push and hold the filter shaker pushbutton in for 15 seconds daily to shake the excess dust from the filter. Clean the filter after every 80 hours of operation.

Use one of the following methods to clean the dust filter:

- Tapping – Tap the filter gently on a flat surface with the dirty side down. Do not damage the edges of the filter element or the filter will not seat properly in the filter frame.
- Air – Blow compressed air, 40 psi (275 kPa) maximum, through the dust filter opposite the direction of the arrows.
- Water – Soak the dust filter in a water and mild detergent solution. Rinse the dust filter until it is clean. The maximum water pressure allowable is 40 psi (275 kPa). Air dry the wet dust filter; do not use compressed air.

NOTE: Be sure the dust filter is dry before reinstalling it in the machine.

TO REMOVE DUST FILTER

1. Place the master power switch in the "off" position.

FOR SAFETY: Before Leaving Or Servicing Machine; Stop On Level Surface, And Turn Off Machine And Remove Key.

2. Push the filter shaker pushbutton to shake the excess dust from the dust filter.
3. Unlatch the two filter cover latches and lower the rear filter cover.

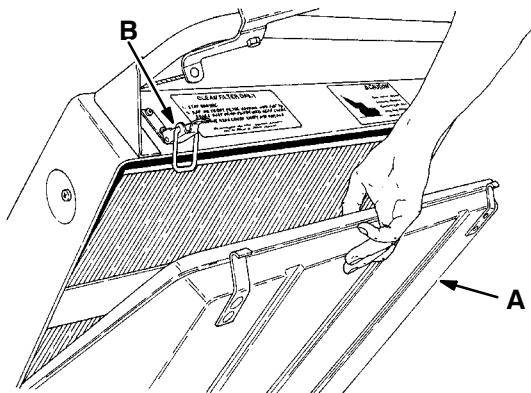

LOWERING REAR FILTER COVER

01214

- A. Rear Filter Cover
- B. Filter Cover Latch

4. Slide the filter retention bar up and out of the slotted retention brackets.

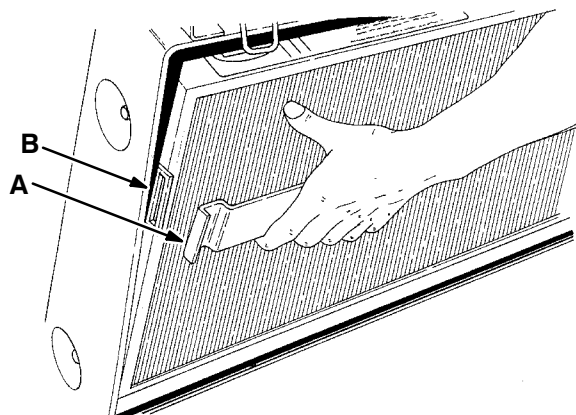

REMOVING FILTER RETENTION BAR

01215

- A. Filter Retention Bar
- B. Retention Bracket

5. Push the filter retention spring upward and slide the filter out of the filter compartment.

TO INSTALL DUST FILTER

1. Push the filter retention spring upward and slide the filter into place on the filter base in the filter compartment.

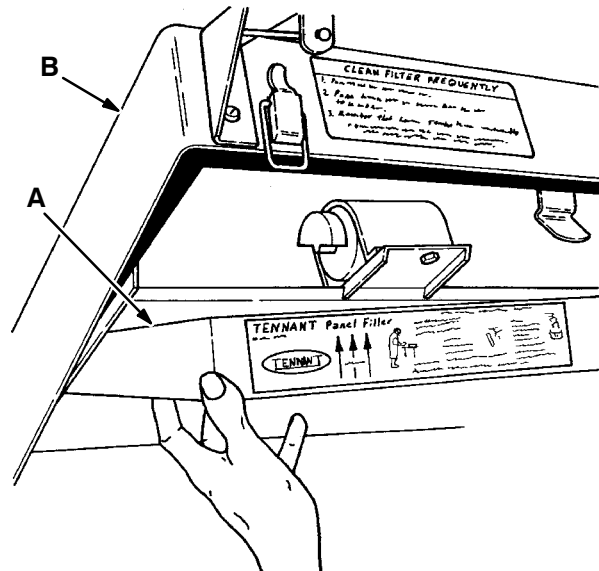

INSTALLING FILTER

02667

- A. Filter
- B. Filter Housing

NOTE: Make sure the arrows on the filter are pointing to the front of the machine.

2. Release the filter retention spring.
3. Slide the filter retention bar down into the slotted retention brackets.
4. Lift the rear filter cover back into the "operating" position.
5. Latch the two filter cover latches.

SKIRTS AND SEALS

SIDE DUST SKIRTS

A dust skirt is located on each side of the brush compartment. They control main brush dusting. The dust skirts should be inspected for wear or damage and adjustment after every 80 hours of operation.

TO ADJUST SIDE DUST SKIRTS

1. Place the master power switch in the "off" position.



WARNING: Brush Throws Debris. Stop Motor Before Lifting Hopper.

2. Grasp the hopper handles; lift and swing the hopper up and out of the machine.
3. Loosen the side dust skirts retaining bolts.

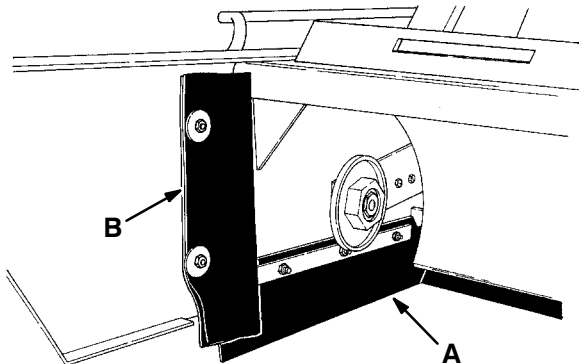

RIGHT SIDE DUST SKIRT

- A. Side Dust Skirt
- B. Side Dust Seal

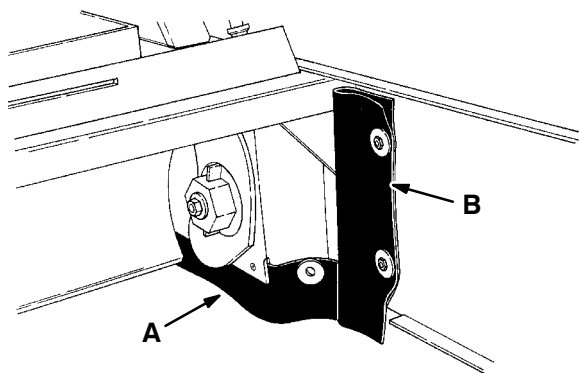

LEFT SIDE DUST SKIRT

- A. Side Dust Skirt
- B. Side Dust Seal

4. Slide the side dust skirts up or down so there is 0.03 to 0.25 in (1 to 5 mm) clearance between the floor and the bottom of the skirt.
5. Tighten the skirt retaining bolts.
6. Reinstall the hopper.

TO REPLACE SIDE DUST SKIRTS

1. Place the master power switch in the "off" position.



WARNING: Brush Throws Debris. Stop Motor Before Lifting Hopper.

2. Grasp the hopper handles; lift and swing the hopper up and out of the machine.
3. Remove the side dust skirts retaining bolts and strips.
4. Remove the side dust skirts.
5. Position the new side dust skirts on the machine so there will be floor clearance of 0.03 to 0.25 in (1 to 5 mm).
6. Install and tighten the skirt retaining strips and bolts.
7. Reinstall the hopper.

HOPPER SIDE SEALS

A seal is located on each side of the machine frame to seal the sides of the hopper. The seals should be checked for wear or damage after every 80 hours of operation.

TO REPLACE HOPPER SIDE SEALS

1. Place the master power switch in the “off” position.



WARNING: Brush Throws Debris. Stop Motor Before Lifting Hopper.

2. Grasp the hopper handles; lift and swing the hopper up and out of the machine.
3. Remove the two side seal retaining bolts.

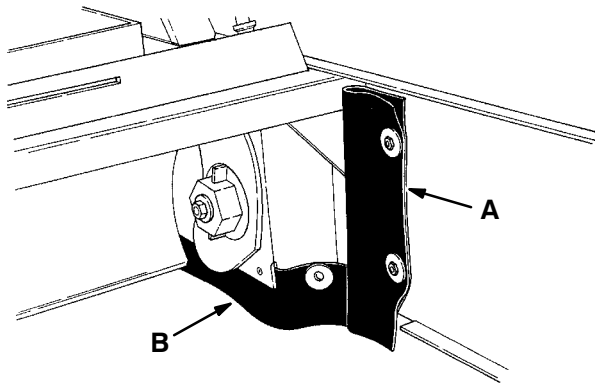

LEFT SIDE DUST SEAL

01208

- A. Side Dust Seal**
- B. Side Dust Skirt**

4. Remove the side seal retaining strip and side seal.
5. Fold new side seal so the mounting holes line up.
6. Slide the retaining bolts through the retaining strip, the side seal, and into the machine.
7. Tighten the seal retaining bolts.

REAR BRUSH SKIRT

A dust skirt is located behind the main brush to control dusting. It should be checked for wear or damage after every 80 hours of operation.

TO REPLACE REAR BRUSH SKIRT

1. Place the master power switch in the “off” position.



WARNING: Brush Throws Debris. Stop Motor Before Lifting Hopper.

2. Remove the debris hopper and battery cover.
3. Disconnect the batteries-to-machine connector.

FOR SAFETY: When Servicing Machine; Disconnect Battery Connections Before Working On Machine, And Avoid Contact With Battery Acid.

4. Remove the batteries from the machine.
5. Carefully tip the machine onto its side.
6. Remove the bottom bolts from each of the rear guide wheel brackets.
7. Remove the single bolt between the two rear guide wheel brackets.

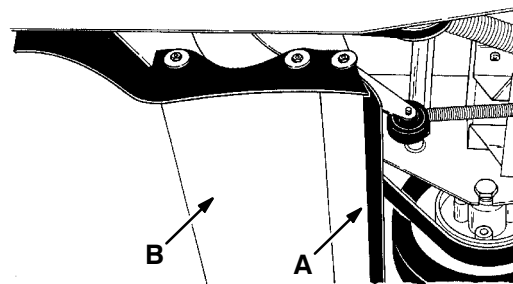

REAR BRUSH SKIRT

01218

- A. Rear Brush Skirt**
- B. Brush Baffle**

8. Pull the rear brush skirt and brush baffle out of the machine.
9. Position the new rear skirt and brush baffle on the machine.
10. Secure the rear skirt and brush baffle to the machine with the three bolts removed earlier.
11. Carefully tip the machine back into the “operating” position.
12. Reinstall the batteries. Reconnect the batteries-to-machine connector.
13. Replace the debris hopper and battery cover.

BELTS AND CHAINS

FLAT PROPELLING BELT

The flat propelling belt transfers power from the motor jackshaft to the drive wheel. Check the belt for wear after every 80 hours of operation. Check the belt tension after every 160 hours of operation.

TO CHECK AND ADJUST FLAT PROPELLING BELT

1. Place the master power switch in the "on" position.
2. Press the clutch handle. The machine should pull forward just before the clutch handle touches the machine stationary handle. If it does not, adjust as follows:

A. Place the master power switch in the "off" position.

FOR SAFETY: Before Leaving Or Servicing Machine; Stop On Level Surface, And Turn Off Machine And Remove Key.

B. Loosen the clutch cable jam nut.

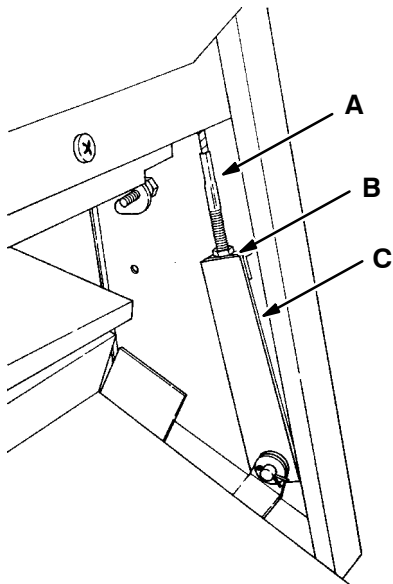

CLUTCH CABLE

01220

- A. Clutch Cable**
- B. Jam Nut**
- C. Clutch Cable Bracket**

C. Loosen clutch cable to relieve belt tension. Thread the clutch cable into the cable bracket to tighten belt tension.

- D. Tighten the clutch cable jam nut to the cable bracket.
- E. Place the master power switch in the "on" position. The machine should not creep or move unless the clutch handle is fully pressed to the machine handle. If the machine moves before the clutch handle is fully pressed, the drive belt will be excessively stressed. Readjust the cable as necessary.

TO REPLACE FLAT PROPELLING BELT

1. Place the master power switch in the "off" position.

FOR SAFETY: Before Leaving Or Servicing Machine; Stop On Level Surface, And Turn Off Machine And Remove Key.

2. Remove debris hopper and battery cover.
3. Disconnect the batteries-to-machine connector.

FOR SAFETY: When Servicing Machine, Disconnect Battery Connections Before Working On Machine.

4. Remove the batteries from the machine.
5. Loosen the clutch cable jam nut.
6. Thread the clutch cable almost out of the cable bracket.
7. Carefully tip the machine on its side.
8. Remove the drive wheel retaining bolt. Take note of bolt spacer positions.

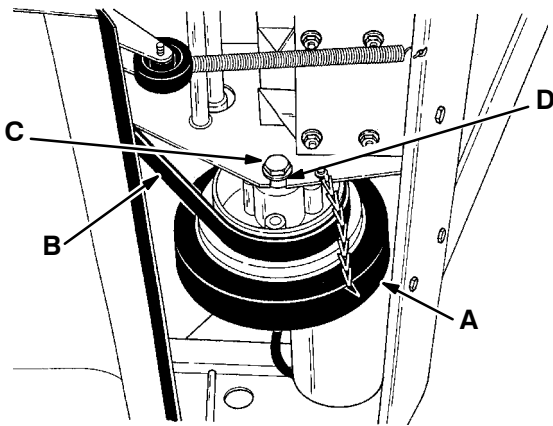

DRIVE WHEEL

01221

- A. Drive Wheel**
- B. Flat Propelling Belt**
- C. Retaining Bolt**
- D. Spacer**

9. Slide the flat propelling belt off the drive wheel.
10. Remove the drive wheel.
11. Remove the flat propelling belt.
12. Slide new flat propelling belt over the belt idler pulley.
13. Position flat propelling belt over the pulley portion of the drive wheel and slide drive wheel into position in machine.
14. Slide the drive wheel retaining bolt through the frame cutout, the drive wheel, and the other side frame cutout.

NOTE: Make sure drive wheel spacers removed earlier are placed in the same positions.

15. Thread the retaining nut onto the retaining bolt and tighten.
16. Carefully tip the machine back into the "operating" position.
17. Reinstall the batteries in the machine.
18. Reconnect the batteries-to-machine connector.
19. Replace the debris hopper and battery cover.
20. Adjust the clutch cable as described in *TO ADJUST FLAT PROPELLING BELT*.

MOTOR DRIVE BELT

The motor drive belt transfers power from the electric motor to the vacuum fan and the motor jackshaft. Check the belt for wear after every 80 hours of operation. Check the belt tension after every 160 hours of operation.

TO CHECK AND ADJUST MOTOR DRIVE BELT

1. Place the master power switch in the "off" position.

FOR SAFETY: Before Leaving Or Servicing Machine, Stop On Level Surface, Turn Off Machine And Remove Key.

2. Unlatch and remove the rear filter cover.
3. Remove the rear shroud.
4. Check the motor drive belt deflection on the span between the motor sheave and the vacuum fan sheave. Proper belt deflection is 0.25 in (5 mm) from a force of 5 to 9 lb (2.3 to 4 kg). Burrough's Tensiometer reading - 55. If the belt does not deflect the proper amount, adjust as follows.

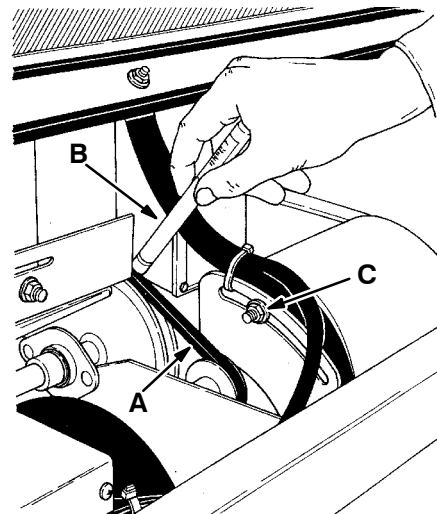

CHECKING MOTOR DRIVE BELT DEFLECTION

01222

- A. Motor Drive Belt**
- B. Belt Tension Gauge**
- C. Motor Mounting Nut**

5. Loosen the electric motor mounting nuts.
6. Pull the motor back to tighten the belt. Do not pry on the motor.
7. Tighten the electric motor mounting bolts.

MAINTENANCE

8. Recheck the belt tension, readjust as necessary.
9. Reinstall the rear shroud and rear filter cover.

TO REPLACE MOTOR DRIVE BELT

1. Place the master power switch in the "off" position.

FOR SAFETY: Before Leaving Or Servicing Machine; Stop On Level Surface, And Turn Off Machine And Remove Key.

2. Unlatch and remove the rear filter cover.
3. Remove the rear shroud and battery cover.
4. Loosen the electric motor mounting nuts.
5. Pivot motor forward to loosen the existing drive belt.

NOTE: For machines equipped with a side brush:

- A. Loosen the locking collar setscrew.

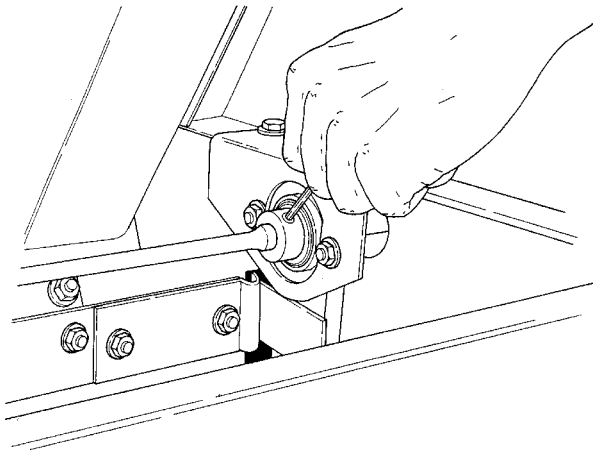

01204

LOOSENING LOCKING COLLAR SETSCREW

- B. Unthread and separate the jackshaft extension from the jackshaft enough to slide the drive belt through. Also note that the jackshaft extension is threaded onto the jackshaft with left hand threads.

6. Remove existing drive belt.
7. Position new drive belt over vacuum fan sheave, large diameter sheave, and motor sheave.

NOTE: For machines equipped with a side brush:

- A. Reconnect and tighten the jackshaft extension to the jackshaft. Remember the jackshaft extension is threaded onto the jackshaft with left hand threads.
- B. Reposition the jackshaft extension support bearing locking collar and tighten its setscrews.
8. Set the motor drive belt tension as described in *TO CHECK AND ADJUST MOTOR DRIVE BELT*.
9. Reinstall the rear shroud and battery cover.
10. Replace the rear filter cover.

BRUSH DRIVE BELT

The brush drive belt transfers power from the motor jackshaft to the brush drive plug. Check the belt for wear after every 80 hours of operation. There is no tension adjustment as it is controlled by a belt idler and spring arrangement.

TO REPLACE BRUSH DRIVE BELT

1. Place the master power switch in the “off” position.

FOR SAFETY: Before Leaving Or Servicing Machine; Stop On Level Surface, And Turn Off Machine And Remove Key.

2. Remove the debris hopper and battery cover.
3. Disconnect the batteries-to-machine connector.

FOR SAFETY: When Servicing Machine, Disconnect Battery Connections Before Working On Machine.

4. Remove the batteries from the machine.
5. Carefully tip the machine on its right side.
6. Disconnect the belt idler spring from the spring bracket.

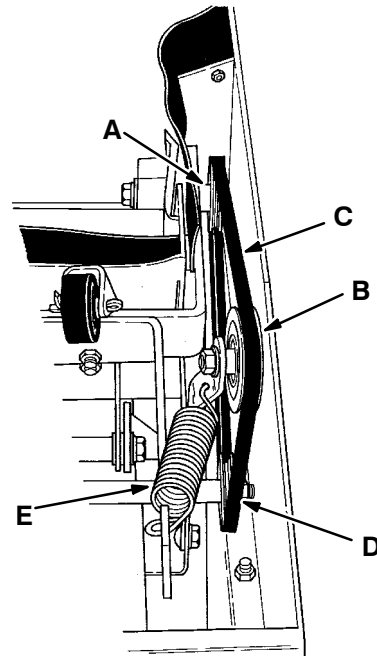

BRUSH DRIVE BELT

01223

- A. Brush Drive Sheave**
- B. Belt Idler Sheave**
- C. Brush Drive Belt**
- D. Motor Jackshaft Sheave**
- E. Belt Idler Spring**

7. Slide the belt off the jackshaft sheave, the brush drive sheave, and out of the machine.

NOTE: A small amount of force from a blunt instrument may be required to get the belt over the end of the jackshaft.

8. Slide the new belt over the end of the jackshaft and into position on the three sheaves.
9. Reconnect the belt idler spring to the spring bracket.
10. Carefully tip the machine into the “operating” position.
11. Reinstall the batteries.
12. Reconnect the batteries-to-machine connector.
13. Replace the debris hopper and the battery cover.

MAINTENANCE

SIDE BRUSH DRIVE BELT

The side brush drive belt transfers power from the jackshaft extension to the side brush gear box. Check the belt for wear after every 80 hours of operation. Adjust the drive belt tension after every 160 hours of operation.

TO ADJUST SIDE BRUSH DRIVE BELT

1. Place the master power switch in the "off" position.

FOR SAFETY: Before Leaving Or Servicing Machine; Stop On Level Surface, And Turn Off Machine And Remove Key.

2. Place the side brush arm in the "operating" position.
3. Remove the five side brush arm cover bolts.
4. Remove the side brush arm cover.
5. Loosen the four gearbox mounting bolts.

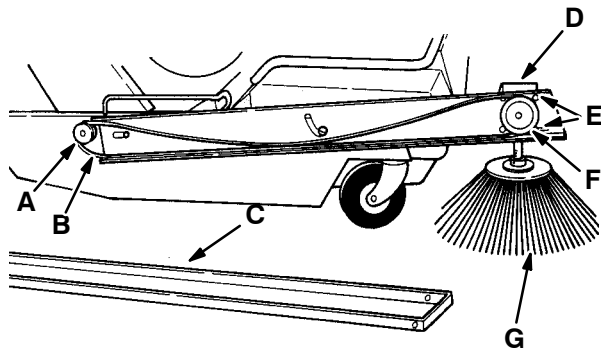

SIDE BRUSH DRIVE BELT

- A. Jackshaft Extension Sheave
- B. Side Brush Drive Belt
- C. Side Brush Arm Cover
- D. Gearbox
- E. Gearbox Mounting Bolts
- F. Gearbox Sheave
- G. Side Brush

6. Slide the gearbox forward to increase belt tension. Slide the gearbox back to decrease belt tension.
7. When belt appears tight, tighten the four gearbox mounting bolts.
8. Replace the side brush arm cover.
9. Place the master power switch in the "on" position and check side brush operation. Readjust the drive belt as necessary.

TO REPLACE SIDE BRUSH DRIVE BELT

1. Place the master power switch in the "off" position.

FOR SAFETY: Before Leaving Or Servicing Machine; Stop On Level Surface, And Turn Off Machine And Remove Key.

2. Place the side brush arm in the "raised" position.
3. Remove the five side brush arm cover bolts.
4. Remove the side brush arm cover.
5. Loosen the four gearbox mounting bolts.
6. Slide the gearbox back, toward the machine.
7. Remove the old drive belt.
8. Position new drive belt over the jackshaft extension sheave and the gearbox sheave.
9. Adjust the side brush drive belt tension as described in *TO ADJUST SIDE BRUSH DRIVE BELT*.

STATIC DRAG CHAIN

A static drag chain is provided to prevent the buildup of static electricity in the machine. The chain is attached near the rear of the machine.

Check the chain for wear after every 160 hours of operation. Make sure the chain is making contact with the floor at all times.

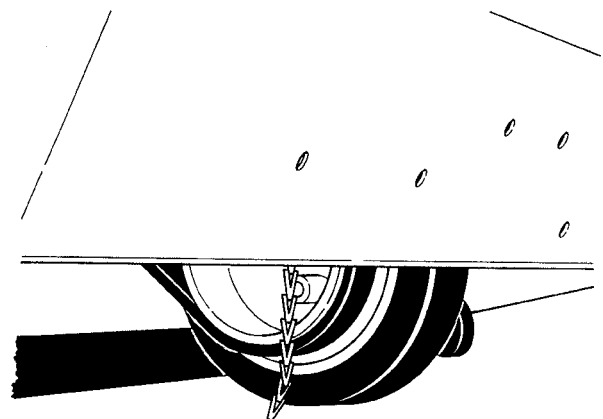

STATIC DRAG CHAIN

PUSHING AND TRANSPORTING THE MACHINE

PUSHING THE MACHINE

If the machine becomes disabled, it can be easily pushed in neutral if necessary.

TRANSPORTING THE MACHINE

1. Position the front of the machine at the loading edge of the truck or trailer.

FOR SAFETY: Use Truck Or Trailer That Will Support The Weight Of The Machine.

NOTE: Empty the hopper before transporting the machine.

2. If the loading surface is not horizontal or is higher than 380 mm (15 in) from the ground, use a winch to load machine.

If the loading surface is horizontal AND is 380 mm (15 in) or less from the ground, the machine may be pushed onto the truck or trailer.

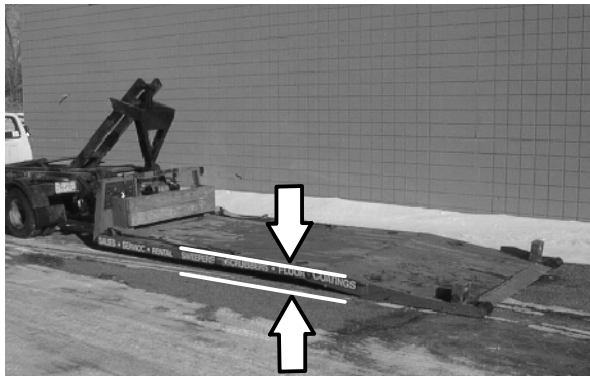

LOADING SURFACE

A. Loading Surface Height

3. To winch the machine onto the truck or trailer, remove the hopper and attach the winching chains to the top of the front casters. Make sure the machine is centered.

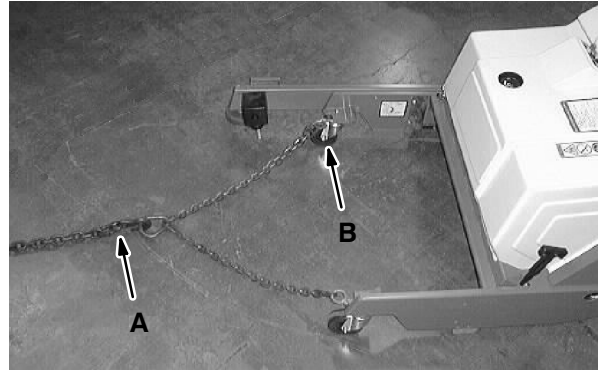

ATTACH WINCHING CHAIN

- A. Winching Chain**
- B. Front Caster**

FOR SAFETY: When Loading Machine Onto Truck or Trailer, Use Winch. Do Not Push The Machine Onto The Truck Or Trailer Unless The Loading Surface Is Horizontal AND Is 380 mm (15 in) Or Less From The Ground.

4. Position the machine onto the truck or trailer as far as possible. If the machine starts to veer off the centerline of the truck or trailer, stop and center the machine.
5. Block the machine tires. Tie down the machine to the truck or trailer before transporting.
6. Secure the front of the machine by wrapping a strap around the hopper and fastening it to the truck or trailer.

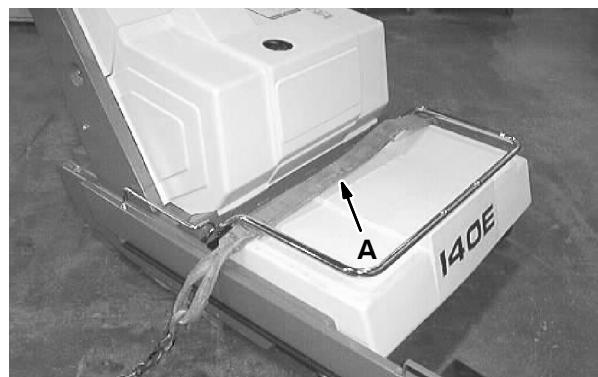

FRONT TIE DOWN STRAP

A. Front Tie Strap

MAINTENANCE

7. Secure the rear of the machine by wrapping straps around each end of the the handle and fastening them to the truck or trailer.

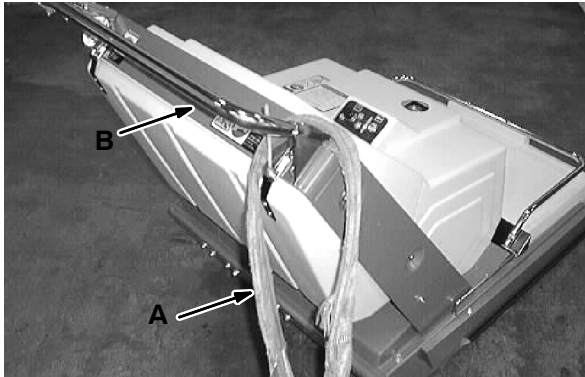

REAR TIE DOWN STRAP

- A. Rear Tie Down Strap**
- B. Handle**

8. If the loading surface is not horizontal or is higher than 380 mm (15 in) from the ground, use a winch to unload machine.

If the loading surface is horizontal AND is 380 mm (15 in) or less from the ground, the machine may be pushed off the truck or trailer.

FOR SAFETY: When Unloading Machine Off Truck or Trailer, Use Winch. Do Not Push The Machine Off The Truck Or Trailer Unless The Loading Surface Is Horizontal AND Is 380 mm (15 in) Or Less From The Ground.

SECTION 4

CONTENTS

	Page
HARDWARE INFORMATION	4-3
STANDARD BOLT TORQUE CHART ..	4-3
METRIC BOLT TORQUE CHART	4-3
BOLT IDENTIFICATION	4-3
THREAD SEALANT AND LOCKING COMPOUNDS	4-3

HARDWARE INFORMATION

The following charts state standard plated hardware tightening ranges for normal assembly applications. Decrease the specified torque by 20% when using a thread lubricant. Do not substitute lower grade hardware for higher grade hardware. If higher grade hardware than specified is substituted, tighten only to the specified hardware torque value to avoid damaging the threads of the part being threaded into, as when threading into speed nuts or weldments.

STANDARD BOLT TORQUE CHART

Thread Size	SAE Grade 5 Torque ft lb (Nm)	SAE Grade 8 Torque ft lb (Nm)
0.25 in	7-10 (9-14)	10-13 (14-38)
0.31 in	15-20 (20-27)	20-26 (27-35)
0.38 in	27-35 (37-47)	36-47 (49-64)
0.44 in	43-56 (58-76)	53-76 (72-103)
0.50 in	65-85 (88-115)	89-116 (121-157)
0.62 in	130-170 (176-231)	117-265 (159-359)
0.75 in	215-280 (291-380)	313-407 (424-552)
1.00 in	500-650 (678-881)	757-984 (1026-1334)





NOTE: Decrease torque by 20% when using a thread lubricant.

METRIC BOLT TORQUE CHART

Thread Size	Class 8.8 Torque ft lb (Nm)	Class 10.9 Torque ft lb (Nm)
M4	2 (3)	3 (4)
M5	4 (5)	6 (8)
M6	7 (9)	10 (14)
M8	18 (24)	25 (34)
M10	32 (43)	47 (64)
M12	58 (79)	83 (112)
M14	94 (127)	133 (180)
M16	144 (195)	196 (265)
M20	260 (352)	336 (455)
M24	470 (637)	664 (900)

NOTE: Decrease torque by 20% when using a thread lubricant.

BOLT IDENTIFICATION

Identification Grade Marking	Specification and Grade
	SAE-Grade 5
	SAE-Grade 8
	ISO-Grade 8.8
	ISO-Grade 10.9

01395

THREAD SEALANT AND LOCKING COMPOUNDS

Thread sealants and locking compounds may be used on this machine. They include the following:

Loctite 515 sealant – gasket forming material. TENNANT® Part No. 75567, 15 oz (440 ml) cartridge.

Loctite 242 blue – medium strength thread locking compound. TENNANT® Part No. 32676, 0.5 ml tube.

Loctite 271 red – high strength thread locking compound. TENNANT® Part No. 19857, 0.5 ml tube.

HOW TO USE THIS MANUAL

This section on *HOW TO USE THIS MANUAL* will tell you how to:

- Find important machine information for ordering correct repair parts.
- Find TENNANT part numbers.
- Order TENNANT parts and supplies.

IMPORTANT INFORMATION

When placing an order for parts, the machine model and machine serial number are important. Refer to the *MACHINE DATA* box which is filled out during the installation of your machine. The *MACHINE DATA* box is located on the inside of the front cover of this manual.

MACHINE DATA	
<i>Please fill out at time of installation for future reference.</i>	
Machine Model Number -	140E
Machine Serial Number -	_____
Machine Options -	_____
TENNANT Representative/phone no. -	_____
Customer ID Number -	_____
Date of Installation -	_____
Manual Number -	MM156
Revision:	17
Published:	12-00

The model number of your machine is on the front of the machine.

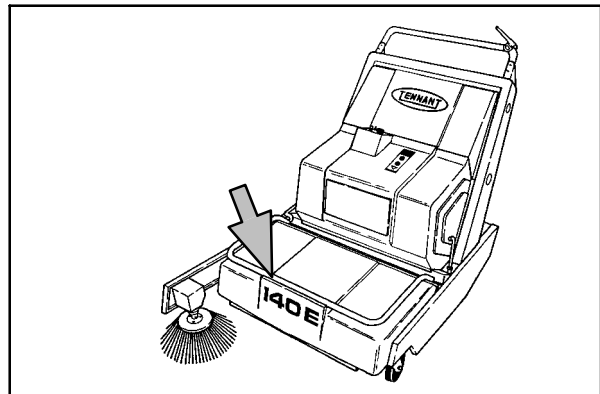

The serial number of your machine is printed on the machine data plate located as shown.

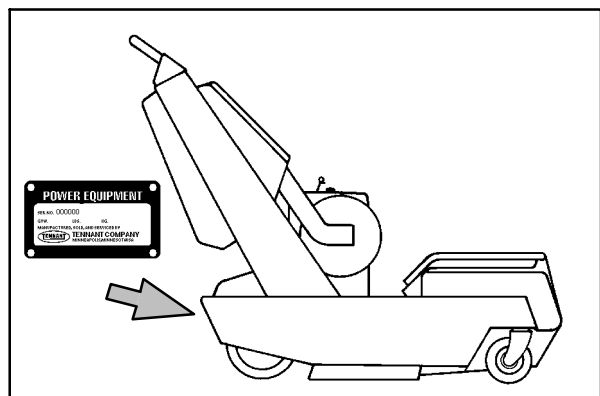

HOW TO USE THIS MANUAL

FINDING A TENNANT PART NUMBER

This manual contains the following sections:

- HOW TO USE THIS MANUAL
- STANDARD PARTS
- OPTIONS
- BREAKDOWNS
- CROSS REFERENCE

The STANDARD PARTS section lists repair parts for standard machines. They are grouped in this general order:

- General wear parts.
- Machine frame and related parts.
- Machine propelling system.
- Scrubbing components.
- Electrical parts.

The OPTION section lists repair parts of options.

The BREAKDOWN section lists available repair parts of major components.

All sections in this manual consist of parts illustrations and corresponding parts lists.

The parts illustrations are numbered with **Ref** numbers which refer to corresponding parts lists.

The parts lists include a number of columns of information:

- **Ref** - column refers to the reference number on the parts illustration.
- ∇ - indicates the part is an assembly.
- ▲ - indicates the part is included in the assembly listed just before it.
- **TENNANT Part No.** - column lists the TENNANT part number for the part.
- **Serial Number** - column indicates the set of machines the part number is applicable to. Serial numbers change when the machine design has been modified. The most current design of the machine is shown in the main illustration, older designs are boxed in a corner of the illustration.
- **Description** - column is a brief description of the part.
- **Qty.** - column lists the quantity of that part used in that area of the machine.

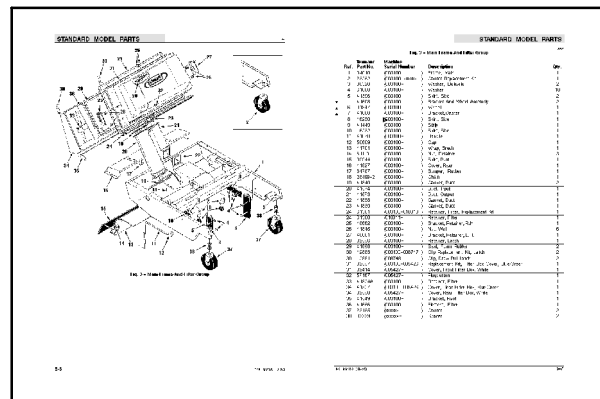

STANDARD MODEL PARTS

Fig. 3 - Main Frame And Filter Group

Ref.	Tennant Part No.	Machine Serial Number	Description	Qty.
1	04010	003100-	Frame, Main	1
2	23262	003100-xxxxxx	Caster Replacement Kit	1
3	38328	003100-	Washer, Belleville	2
4	61036	003100-	Washer	10
5	41396	003100-	Skirt, Skid	2
6	41868	003100-	Bracket And Wheel Assembly	2
▲ 6	01847	003100-	Wheel	1
▲ 7	41630	003100-	Bracket,Caster	1
8	15230	003100-	Skirt, Skid	1
9	41443	003100-	Strip	1
10	15232	003100-	Skirt, Skid	1
11	41670	003100-	Handle	1
12	63630	003100-	Cap	1
13	41701	003100-	Wires, Brush	1
14	61110	003100-	Nut, Retainer	3
15	09944	003100-	Skirt, Dust	1
16	41627	003100-	Cover, Rear	1
17	64757	003100-	Dumper, Rubber	1
18	28493-2	003100-	Chain	1
19	41840	003100-	Gasket, Duct	2

NOTE: If a service kit is installed on your machine, be sure to keep the **INSTRUCTION BULLETIN** which came with the kit. It contains repair parts numbers needed for ordering future parts.

NOTE: Fasteners used in this machine may be metric or non-metric. Take care when replacing hardware to replace with same thread size.

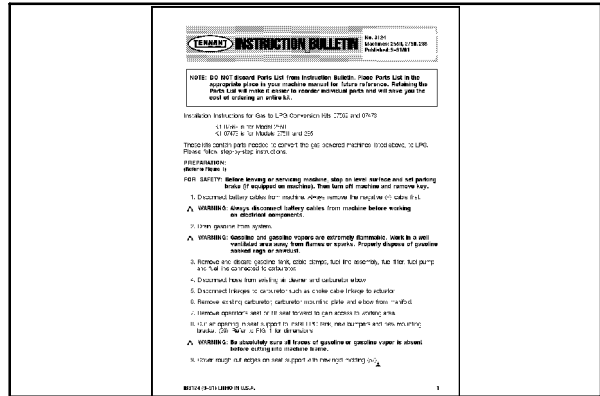

PLACING AN ORDER

Orders may be placed by phone, fax, or by mail. Phone orders may need written confirmation. Follow the steps below to insure prompt delivery:

1. Identify the model number of your machine.
2. Identify the serial number of your machine.
3. Find the part number of the part you need. Do not order by page number or reference number. If you are not able to find the part number, call your TENNANT representative for help or send the old part as a sample.
4. Determine the quantity of the part you need.
5. Provide the following company information:
 - Company name
 - Customer ID Number
 - Shipping address
 - Billing address
 - First and last name of person ordering parts
 - Telephone number
 - Purchase order number
6. Provide definitive shipping instructions.

HOW TO USE THIS MANUAL

Any claim for loss or damage to a shipment in transit should be filed promptly with the transportation company making the delivery. Shipments will be complete unless the packing list or order acknowledgement indicates items back ordered.

If parts received are suspected to be incorrect or defective, please contact the TENNANT representative from whom you ordered the part. They will give authorization for return and/or handle replacement shipments when required.

CONTENTS

	Page
Fig. 1 - Recommended General Maintenance Items	6-3
Fig. 2 - Replacement Brushes	6-4
Fig. 3 - Main Frame and Charger Group	6-6
Fig. 4 - Handle Group	6-8
Fig. 5 - Hopper Assembly	6-9
Fig. 6 - Brush Drive Group	6-10
Fig. 7 - Motor and Wheel Drive Group	6-12
Fig. 8 - Filter Group	6-14
Fig. 9 - Battery Group	6-16
Fig. 10 - Wire Harnesses Group	6-18
Fig. 11 - Vacuum Fan Group	6-20
Fig. 12 - Label Kit	6-21

*NOTE: SECTION 6, STANDARD MODEL PARTS,
lists repair parts for a standard model machine.*

Fig. 1 - Recommended General Maintenance Items

Ref.	Tenant Part No.	Machine Serial Number	Description	Qty.
▽	59455	(006900-) Replmt.Parts Pkg 140e	1
▲	41656	(006900-) Filter Pkg, Dust, Panl, 119plts	1
▲	32862	(006900-) Belt, V, [3vx] 28.0l	1
▲	23243	(006900-) Belt, V, [3l] 36.0l	1
▲	23279	(006900-) Belt, V	1
▲	09944	(006900-) Skirt	2
▲	41563	(006900-) Skirt, .06th, 10.00w 30.00l, 06/0.31h	1
▲	41396	(006900-) Skirt	2
▲	09944	(006900-) Skirt	1
▲	16232	(006900-) Skirt	1
▲	16230	(006900-) Skirt	1
▲	01847	(006900-) Wheel, 1.6d 0.72w 0.21b	2
	41678	(006900-) Belt, V, [3l] 80.0l	1
▽	03972	(006900-) Kit, Maint, Seals, Gas, [140]	1
▲	47037	(006900-) Adhesive, Contact, [1357 5.0oz]	1
▲	41858	(006900-) Seal, Foam, Rbr, .38 0.75w 94.0l	3
▲	02592	(006900-) Seal, Rbr, Open, 0.19th, 0.62w 04.6l	2
▲	41838	(006900-) Gasket, Duct, Output	1
▲	41837	(006900-) Hinge, Pyp, .06 2.0 W 03.3l 4/0.34h	1
▲	41840	(006900-) Gasket, Duct	2
▲	60378	(006900-) Seal, Rbr, Open, 0.19th, 0.62w	1
▽	03973	(006900-) Kit, Maint, Skirt, Gas, [140]	1
▲	16232	(006900-) Skirt	1
▲	41396	(006900-) Skirt	2
▲	61088	(006900-) Washer, 0.19b 1.00d .06, Stl, PI	10
▲	16230	(006900-) Skirt	1
▲	09944	(006900-) Skirt	1
▲	61110	(006900-) Nut, U, .25-20	3
▲	09944	(006900-) Skirt	1
▲	41563	(006900-) Skirt, .06th, 10.00w 30.00l, 06/0.31h	1

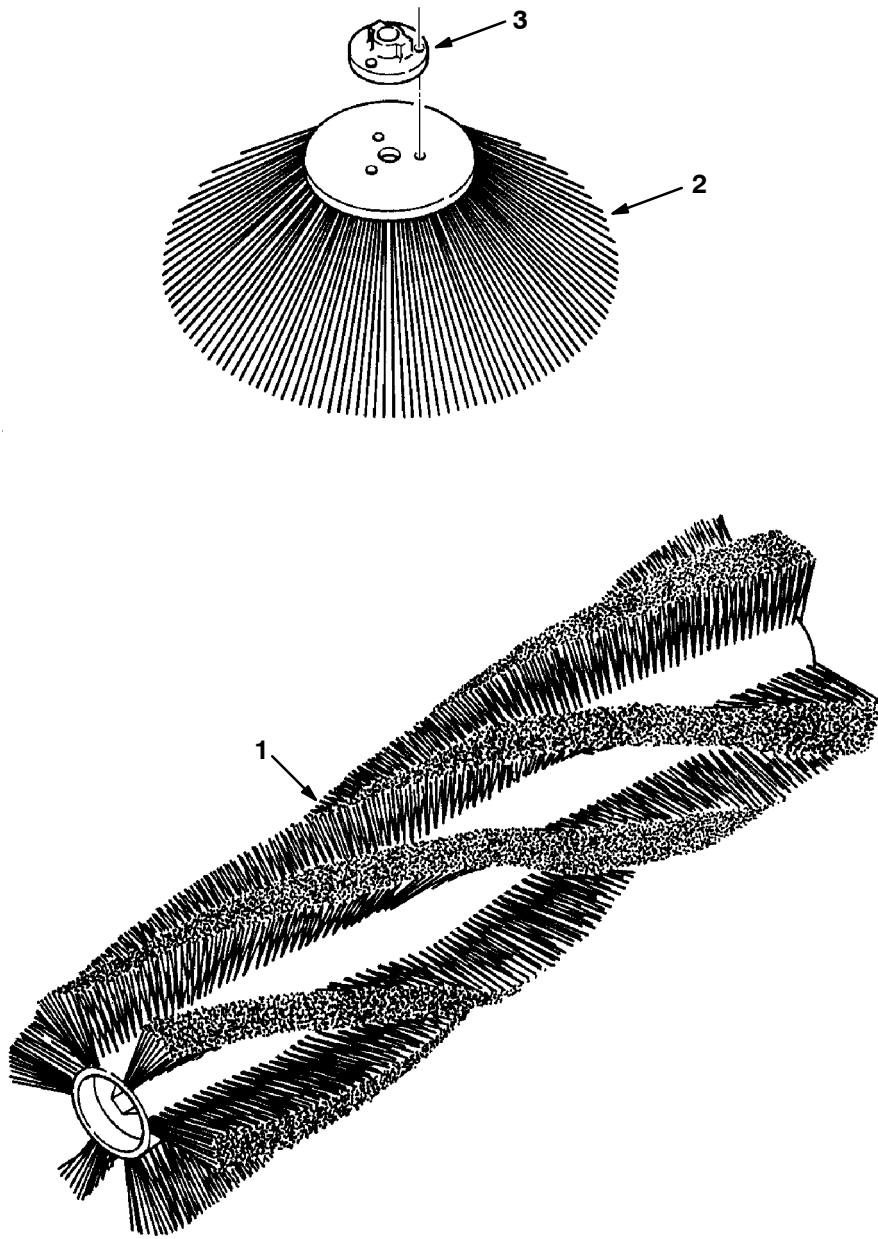

Fig. 2 - Replacement Brushes

Fig. 2 - Replacement Brushes

Ref.	Tennant Part No.	Machine Serial Number	Description	Qty.	
1	41457	(006900-) Brush, Swp, 28l, 6 Dr, Pyp	1	
1	32856	(006900-) Brush, Swp, 28l, 12 Sr, Umx Carpet	1	
▽	2	41673	(006900-) Brush Assy, Disk, Swp, 13.0 D, Pyp	1
▲	3	28013B	(006900-) Adaptor, Brush, Side, .628b	1

STANDARD MODEL PARTS

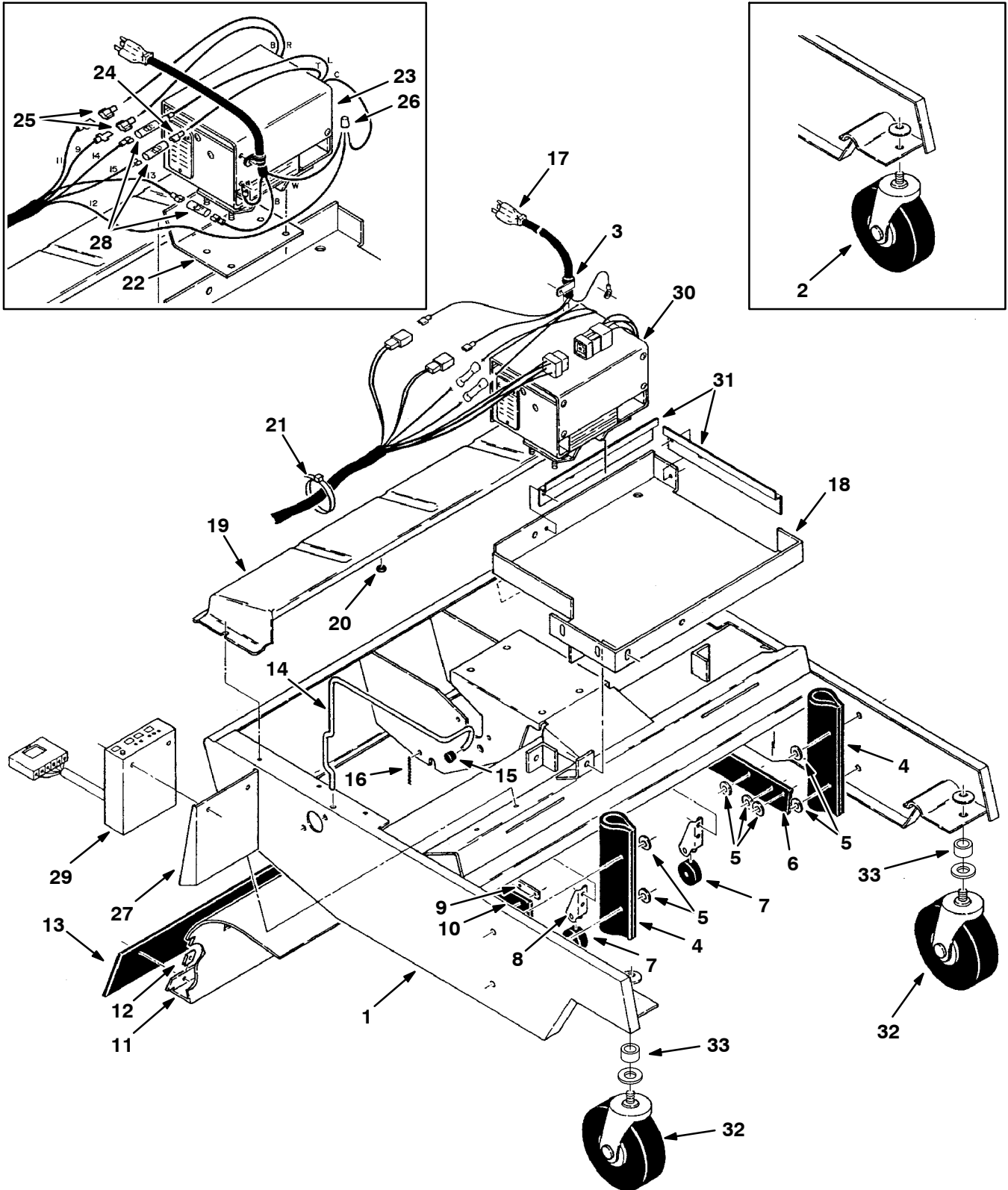

Fig. 3 - Main Frame and Charger Group

Fig. 3 - Main Frame and Charger Group

Ref.	Tenant Part No.	Machine Serial Number	Description	Qty.
1	06234	(006900-007346)	Frame Assy, F/[61010b], [140e]	1
1	04010	(007347-	Frame Wldt, Main, [140/140e]	1
2	41624	(006900-xxxxxx)	Caster Rep.By23252	2
3	26395-2	(006900-	Clamp, Cable, Stl, 0.38d X 0.38w, 1h	1
4	41396	(006900-	Skirt	2
5	61088	(006900-	Washer, 0.19b 1.00d .06, Stl, Pl	10
6	16230	(006900-	Skirt	1
▽	41608	(006900-	Bracket / Wheel Assy	2
▲	7 01847	(006900-	Wheel, 1.6d 0.72w 0.21b	1
▲	8 41600	(006900-	Bracket, Mtg, Caster	1
9	41449	(006900-	Strip	1
10	16232	(006900-	Skirt	1
11	41701	(006900-	Panel, Brush	1
12	61110	(006900-	Nut, U, .25-20	3
13	09944	(006900-	Skirt	1
14	41670	(006900-	Handle	1
15	50609	(006900-	Cap, Plug	1
16	28499-2	(006900-	Chain, Sash, #35, 05.3l 09 Link	1
17	60496	(006900-	Cord, Ele, 16-3 18.0inch	1
18	04007	(007347-	Tray	1
19	41827	(006900-	Cover, Frame, Rear, [140e]	1
20	64757	(006900-	Bumper, Rbr, 0.5d 0.14t Adh	1
21	49266	(006900-	Tie, Cable, Nyl, 07.3l .19w 1.8 Max D	4
22	61046	(006900-007346)	Bracket, Mounting (Replaced by none)	1
23	60493	(006900-009736)	Kit, Replmt, Chrgr, F/ 50708	1
▽	23 60507	(006900-009736)	Kit, Replmt, Chrgr, F/ 50709	1
▲	24 43942	(006900-009736)	Terminal, Qdc, [.25f, Ins ,14]	1
	25 50456	(006900-009736)	Terminal, Qdc, [.25m, Insf,10]	2
	26 04756	(006900-009736)	Wire	1
	27 60494	(009737-	Bracket, Mtg, Cntrl Panl	1
	28 15006	(006900-009736)	Terminal, Qdc, [.25m, Inss,]	3
	29 50049	(009737-	Controlbox, Charger	1
	30 50050	(009737-	Charger, 24vdc 015a 60hz 120vac Auto	1
	30 50116	(009737-	Charger, 24vdc 15a 50hz	1
	31 70004	(006900-	Bracket, Spacer, Battery	2
	32 23155	(xxxxxx-	Caster, Stem, Swivel, 4.0 D	2
	33 82229	(006900-	Sleeve	2

STANDARD MODEL PARTS

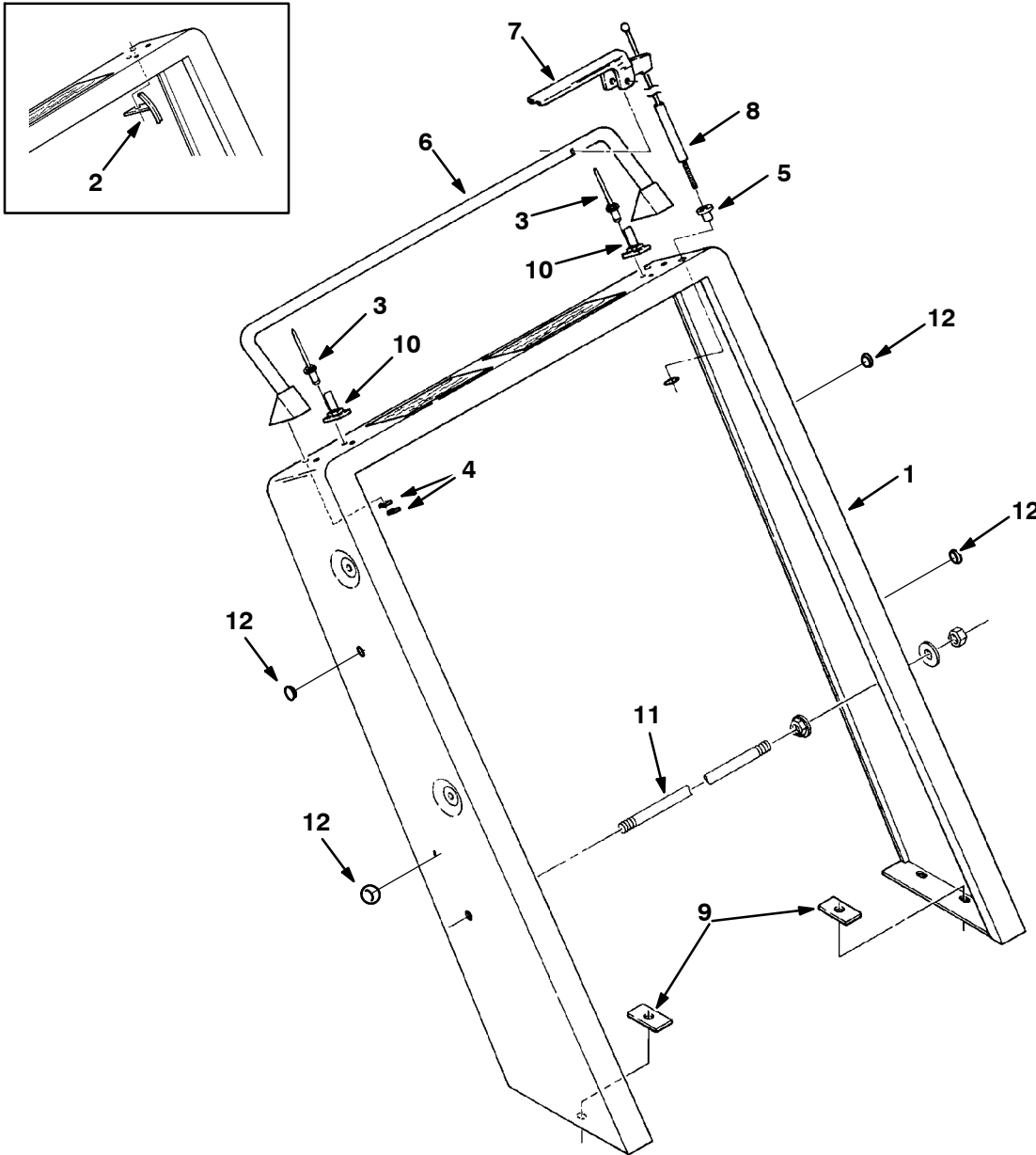

Fig. 4 - Handle Group

02632

Ref.	Tennant Part No.	Machine Serial Number	Description	Qty.
1	31914	(003100-005426)	Kit, Replmt, Frame, F/ 48625-1	1
1	31912	(005427-008747)	Kit, Replmt, Frame, F/ 09003	1
1	31918	(008748-)	Handle Assy, W/ Label, [140]	1
2	61379	(003100-010049)	Kit, Replmt, Cable Guide, Clutch	1
3	60428	(003100-)	Rivet, Blind, .188d X 0.58 X .38d, Stl	4
4	41665	(003100-)	Nut, Speed, Retainer, .25-20	4
5	61377	(010050-)	Bushing, Flng, 0.28b 0.50d 0.50l, Pye	1
6	41567-1	(003100-)	Handle Assy, Tube, 1.00d 24.9w	1
7	41832	(003100-)	Handle, Clutch	1
8	41829	(003100-)	Cable, .13d, 28.5l, .25-20 /.38ball	1
9	08868	(003100-)	Bar, Flt, Stl, 0.12 X 0.9 X 2.0 L	2
10	23709	(003100-)	Catch	2
11	60426	(003100-)	Rod	1
12	379000	(003100-)	Button, Plug	4

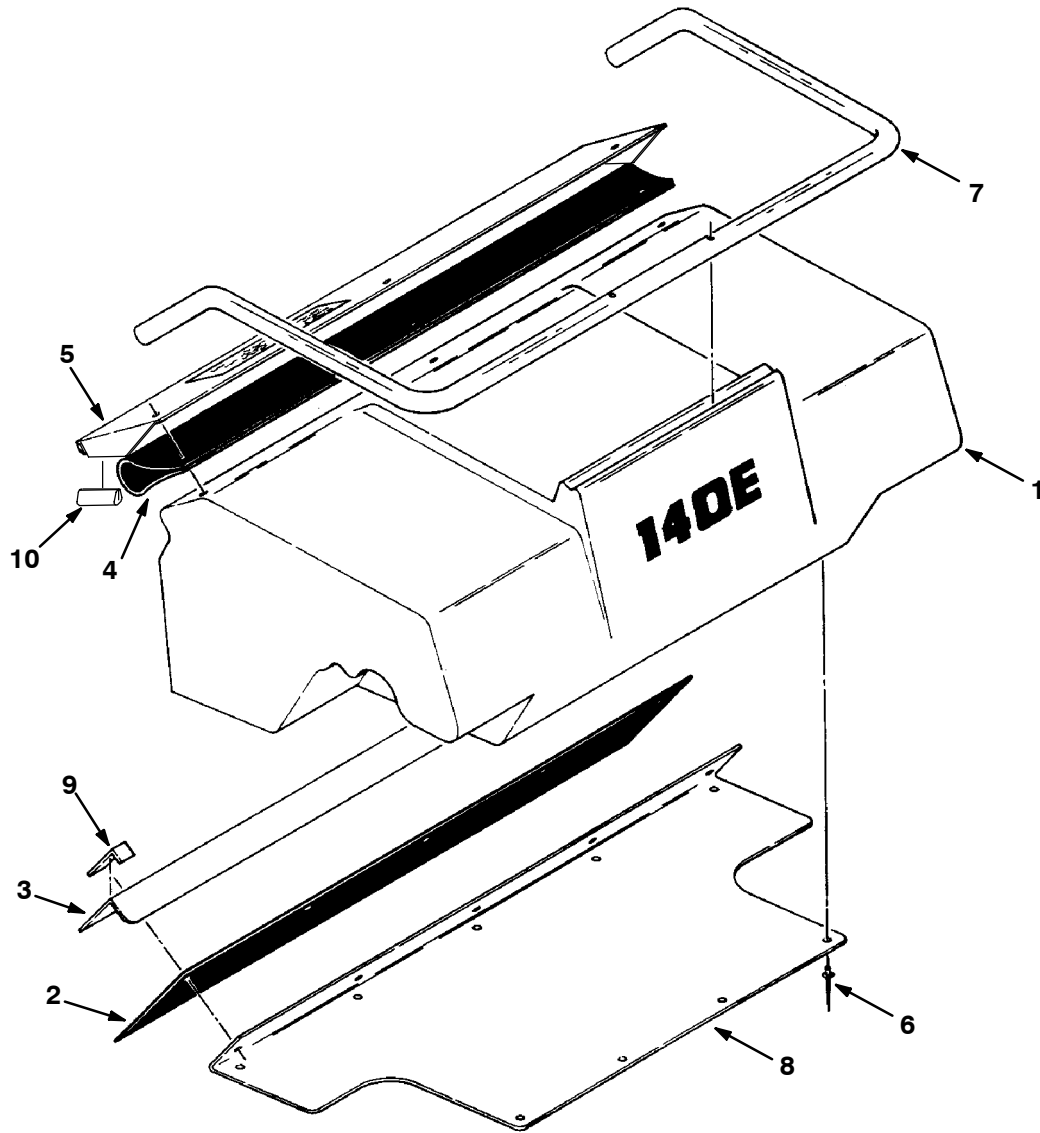

Fig. 5 - Hopper Assembly

Ref.	Tennant Part No.	Machine Serial Number	Description	Qty.
▽ 1	41870	(006900-) Hopper Assy, [140/140e/141e]	1
▲ 2	09944	(006900-) Skirt	1
▲ 3	41447	(006900-) Retainer, Skirt, Hppr, Rear,	1
▲ 4	41563	(006900-) Skirt, .06th, 10.00w 30.00l, 06/0.31h	1
▲ 5	41568	(006900-) Retainer, Seal, W/ Label, Rear	1
▲ 6	41732	(006900-) Rivet, Blind, .188D X 0.45 X .38D, Stl	9
▲ 7	41513	(006900-) Handle, Hppr	1
▲ 8	41448	(006900-) Shield, Hppr	1
▲ 9	02592	(006900-) Seal, Rbr, Open, 0.19th, 0.62w 04.6l	2
▲ 10	398207	(003100-) Molding, Trim, Rubber, .06 1.4l	2

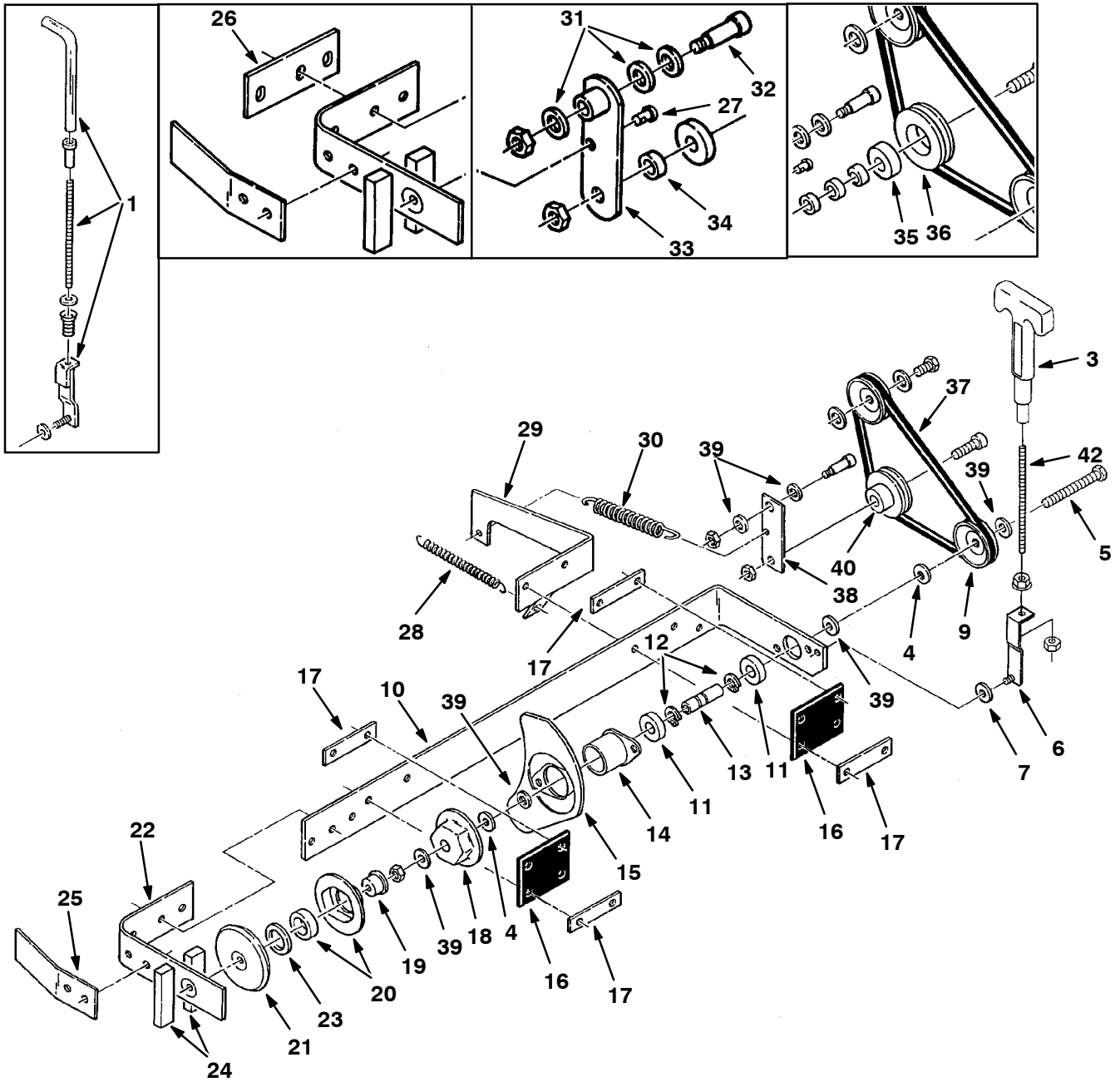

Fig. 6 - Brush Drive Group

Fig. 6 - Brush Drive Group

Ref.	Tennant Part No.	Machine Serial Number	Description	Qty.
1	25147	(006900-010682)	Kit, Replmt, Handle / Bracket	1
2	41743	(006900-010682)	Bushing, Flng, 0.30b 0.52d . L, Nyl	1
3	25950	(010683-) Handle, Lift, Brush, [140]	1
4	41142	(006900-) Washer, Lock, Int-Ext, .38	1
5	21198	(006900-) Screw, Hex, .38-16 X 1.25, 5	1
6	25148	(010683-) Bracket Wldt, Brush Lift	1
7	24924	(006900-) Washer, 0.28b 0.62d .06, Nyl	1
8	32553	(006900-010682)	Spring, Cmpr, 0.72od .55wir 3.0l	1
9	32562	(006900-) Sheave, [3v], 1grv, 03.5pd 0.38b	1
10	16237	(006900-) Arm, Brush, Main, Drive	1
▽	41648	(006900-) Shaft	1
▲	11 41360AM	(006900-) Bearing, Ball, 0.59b 1.26d 0.35w	2
▲	12 01516	(006900-) Ring, Retaining, Ext, 0.59d, Basic	2
▲	13 47751	(006900-) Shaft	1
▲	14 41362	(006900-) Bushing Assy, Flng, 2 Hole, 1.25b	1
	15 41363	(006900-) Cover, Flng, Drive, Gray	1
	16 41837	(006900-) Hinge, Pyp, .06 2.0 W 03.3l 4/0.34h	2
	17 41411	(006900-) Strip, Stl, 0.07th X 00.90w, 03.30l	4
	18 41357	(006900-) Cup, Drive, Brush Tube-Grey	1
▽	41518	(006900-) Arm Assy, Brush, Main, [140]	1
▲	19 41385	(006900-) Bar, Hex, Stl, Mach, Sleeve, Idler	1
▲	20 41649	(006900-) Cup & Bearing Assy -Brush	1
▲	21 41386	(006900-) Guard, Cup, Gray	1
▲	22 41509	(006900-) Arm, Brush, Main, Rh	1
▲	23 09006	(006900-) Washer	1
	24 41637	(006900-) Seal, Foam, Rbr, .50 0.75w 03.0l	2
	25 41669	(006900-) Plate	1
	26 41864	(006900-008073)	Plate Rep.Bynone	1
	27 39019	(006900-008087)	Pin, Clevis, 0.37 D X 0.75l	1
	28 29260	(006900-) Spring, Extn, 0.75od X 0.06wir, 5.3l	1
	29 41741	(006900-) Bracket, Mtg, Spring	1
	30 29499	(006900-) Spring, Extn, 0.75od X 0.11wir, 4.5l	1
	31 41818	(006900-008087)	Washer, 0.38b 0.56d .03, Stl	3
	32 56060	(006900-008087)	Bolt, Shld, .38d X 1.00, .31-18	1
	33 09971	(006900-008087)	Kit, Replmt, Idler Arm, F/ 41817	1
	34 49566	(006900-008087)	Sleeve	1
	35 01845	(006900-009133)	Bearing, Ball, 0.39b 1.18d 0.35w	1
	36 50038	(006900-009133)	Kit, Replmt, Idler, F/ [41819&47]	1
	37 32862	(006900-) Belt, V, [3vx] 28.0l	1
	38 09945	(008088-) Idler Arm	1
	39 32491	(008088-) Washer, Flt, .31 Std	6
	40 02355	(009134-) Sheave, [3v], 1grv, 03.0pd 0.38brg	1
	41 24227	(006900-010682)	Washer, Flat	1
	42 31906	(010683-) Rod, Thrd, Full, .31-18 05.7l	1

STANDARD MODEL PARTS

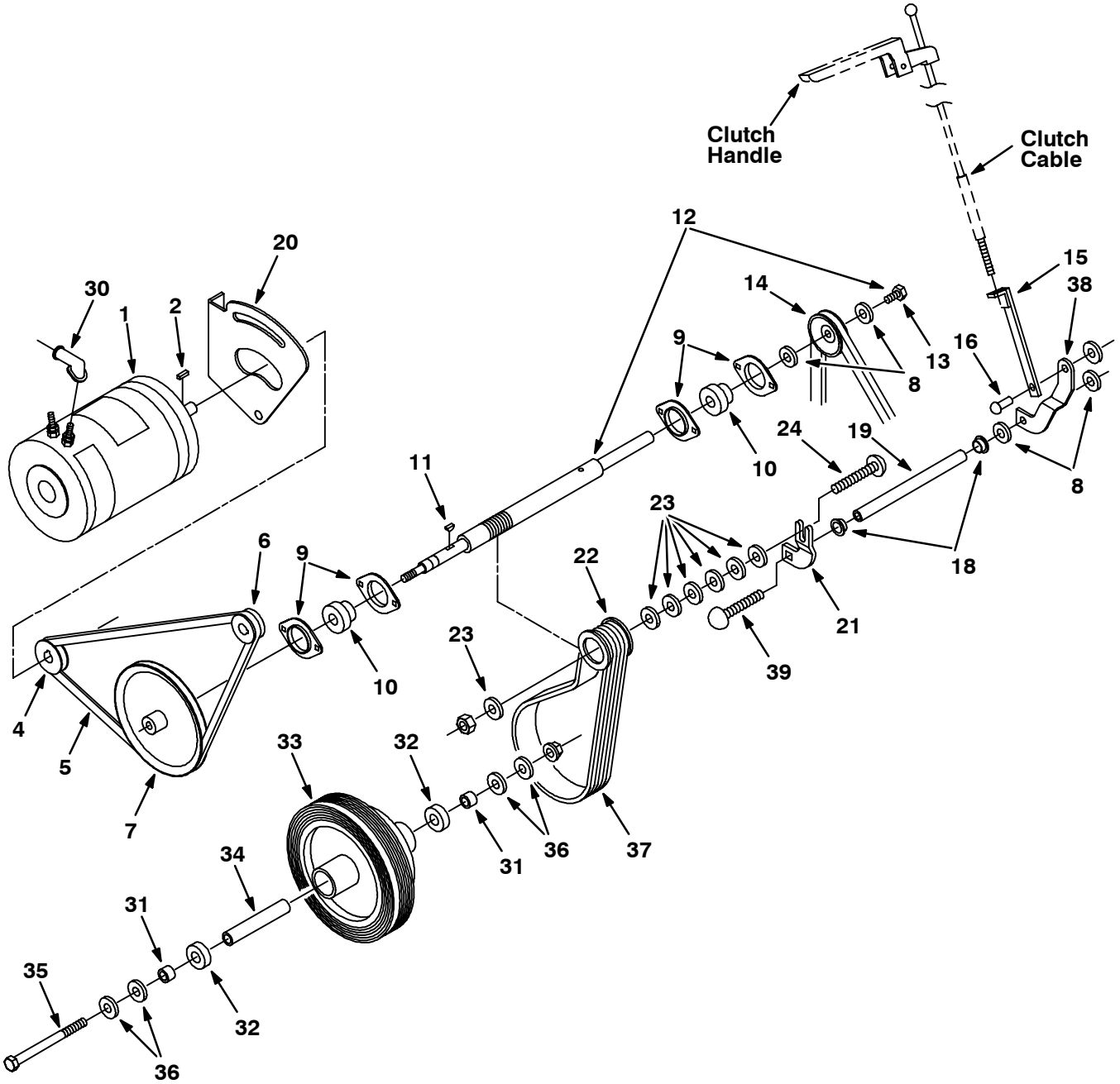
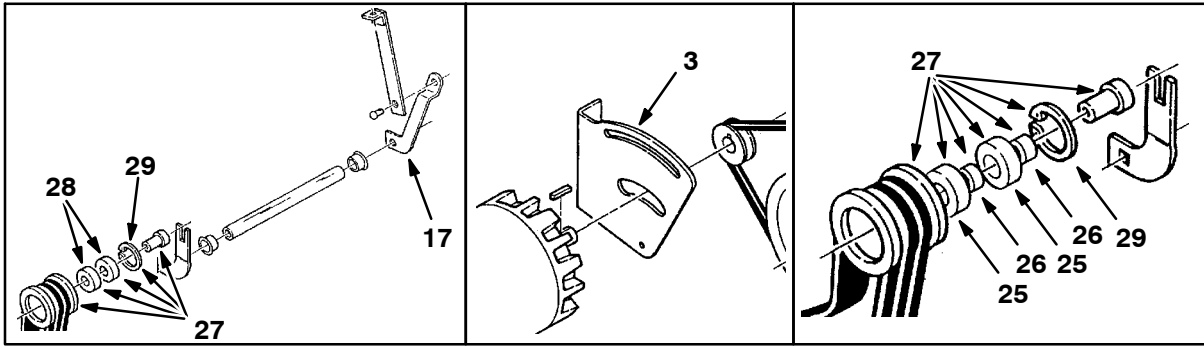

Fig. 7 - Motor and Wheel Drive Group

Fig. 7 - Motor and Wheel Drive Group

	Ref.	Tennant Part No.	Machine Serial Number	Description	Qty.
▽	1	61035	(006900-009032)	Motor Rep. By 50091	1
▲		37490	(006900-009032)	Brush, Motor, Set	1
▽	1	50066	(009033-013226)	Motor, Ele, .8hp	1
▲		50122	(009033-013226)	Brush, Motor, Set	1
▲		391838	(009033-013226)	Brush Holder, With Brushes	1
▲		86041	(009033-013226)	Bearing, Ball, 0.67b 1.57d 0.47w	1
▲		46390AM	(009033-013226)	Bearing, Ball, 0.79b 1.85d 0.55w	1
	1	377412	(013227-	Motor, Ele, 24Vdc 0.75Hp 2100Rpm 28.0A	1
	2	00911	(006900-	Key, Sq, 0.19 X 0.19, 00.75l	1
	3	41844	(006900-009032)	Bracket, Mtg, Motor, [Prestolite]	1
	4	28760	(006900-	Sheave, [3l], 1grv, 01.8pd 0.62b	1
	5	23243	(006900-	Belt, V, [3l] 36.0l	1
	6	16925	(006900-	Sheave, [3l], 1grv, 01.6pd 0.62b	1
	7	41863	(006900-	Sheave, [3l], 1grv, 06.4pd 0.38b	1
	8	41187	(006900-	Washer, Belleville, .38	4
	9	48636	(006900-	Flange, Brg, 1.5id 2h	4
	10	48635	(006900-	Bearing, W/ Collar, 0.63b 1.57d 1.12w	2
	11	00500-1	(006900-	Key, Woodruff, 0.09 0.50, [Asa#0304]	1
▽	12	04594	(006900-	Kit, Replmt, Shaft, F/39571	1
▲	13	06460	(006900-	Screw, Hex, .38-16 X 1.00, Lh	1
	14	32563	(006900-	Sheave, [3v], 1grv, 02.2pd 0.38b	1
	15	41828-1	(006900-	Bracket Wldt, Clutch, Propel	1
	16	04733-2	(006900-	Pin, Clevis, 0.37 D X 0.62l	1
	17	31905	(006900-008512)	Kit, Replmt, Arm, Clutch, F/ 41611	1
	18	41434	(006900-	Bushing, Flng, 0.62b 0.68d 0.00l, Nyl	2
	19	41571	(006900-	Shaft, Cntrl, Clutch	1
	20	50090	(009033-	Bracket Wldt, Motor, [Ohio]	1
▽		31233	(006900-	Arm Assy, Clutch, Propel, [140]	1
▲	21	41521	(006900-	Arm, Idler, Clutch, Propel, Rh	1
▲	22	01199	(010478-	Sheave, Flat, 1.8d 1.38w 0.67b	1
▲	23	32491	(010478-	Washer, Flt, .31 Std	7
▲	24	378964	(006900-	Bolt, Carriage, .38-16 X 2.00	1
	25	28010	(009092-010477)	Bearing, Ball, 0.62b 1.38d 0.43w	2
	26	29091	(009092-010477)	Sleeve	2
	27	61487	(006900-010477)	Kit, Replmt, Idler, F/31230/1/2	1
	28	50040	(006900-009091)	Kit, Replmt, Bearing, F/41646	2
	29	01513	(006900-010477)	Ring, Retaining, Int, 1.38d, Basic	1
	30	02076	(006900-	Boot, 90deg .50d .57d X .84	1
▽		41871	(006900-	Tire Assy, Solid, 08.0x2.0 , W/ Brg	1
▲	31	29091	(006900-	Sleeve	2
▲	32	28010	(006900-	Bearing, Ball, 0.62b 1.38d 0.43w	2
▲	33	50111	(006900-	Tire Assy, Solid, 08.0x2.0 1.37b	1
▲	34	41504	(006900-	Tube, Steel	1
▲	35	45872	(006900-	Screw, Hex, .50-13 X 6.50, 2, Unpl	1
▲	36	32486	(006900-	Washer, Flt, .50 Sae	4
	37	23279	(006900-	Belt, V	1
	38	25997	(008513-	Arm, Clutch, Propel, Lh	1
	39	10819	(006900-	Bolt, Carriage, .38-16 X 1.00	1

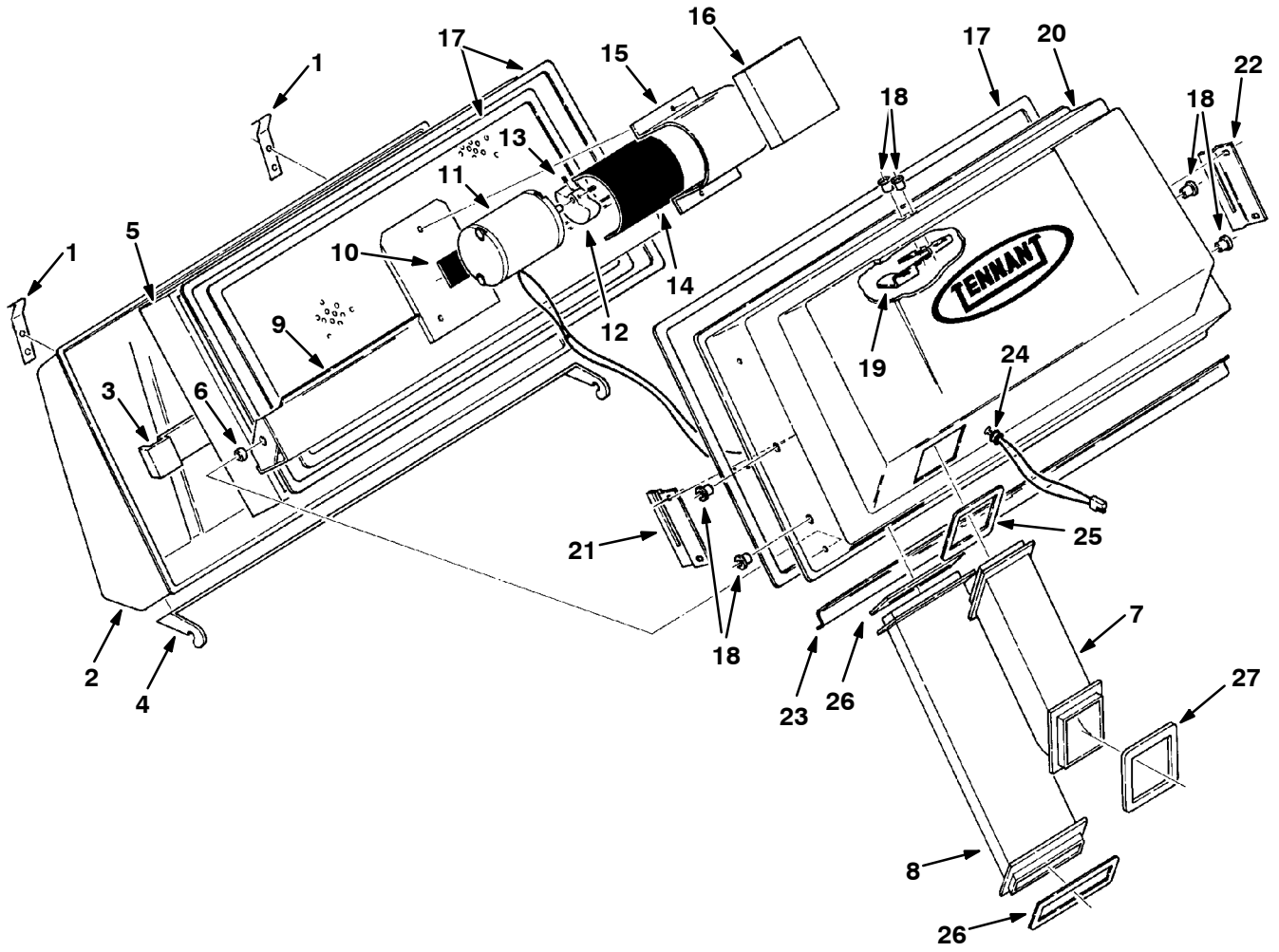

Fig. 8 - Filter Group

Fig. 8 - Filter Group

Ref.	Tenant Part No.	Machine Serial Number	Description	Qty.
1	12881	(006900-) Clip, Latch	2
2	02558	(006900-) Cover, Filterbox, Rear	1
3	41824A	(006900-) Retainer	1
4	41549	(006900-) Bracket, Pivot, Fltr Cover	1
5	41656	(006900-) Filter Pkg, Dust, Panl, 119plts	1
6	40282	(006900-) Sleeve	2
7	41573	(006900-) Duct, Outlet, 3.0 3.0 7.8l Pye	1
8	41574	(006900-) Duct, Input	1
▽	02421	(006900-) Shaker, Filter, Dust	1
▲	9 31271	(006900-) Frame, Shaker, Fltr, [140e]	1
▲	10 36661	(006900-) Bar, Flt, Rbr, 0.06 X 1.00 X 4.00l	1
▲	11 44939	(006900-) Motor, Ele, 36vdc Hp Shaker	1
▲	12 34773	(006900-) Weight, Eccentric	1
▲	13 20634	(006900-) Screw, Set, #10-24 X 0.25, NI	2
▲	14 36658	(006900-) Bar, Flt, Rbr, 0.06 X 4.00 X 5.00l	1
▲	15 36666	(006900-) Strap	1
16	34217	(006900-) Insulation, Acstc, 1.0th, 03.9w X 04.8l	1
17	41858	(006900-) Seal, Foam, Rbr, .38 0.75w 94.0l	3
18	41845	(006900-) Nut, Isolator, .25-20 #1/4-S	6
19	32556	(006900-) Retainer	1
20	02414	(006900-) Cover, Filterbox, Front, W/ Logo	1
21	48662	(006900-) Bracket, Retainer, Fltr, Rh	1
22	48661	(006900-) Bracket, Retainer, Fltr, Lh	1
23	41612	(006900-) Retainer Rep.By61381	1
24	47591	(006900-006944) Strainrelief	1
24	29232	(006945-) Strainrelief	1
25	41839	(006900-) Gasket, Duct	1
26	41840	(006900-) Gasket, Duct	2
27	41838	(006900-) Gasket, Duct, Output	1

STANDARD MODEL PARTS

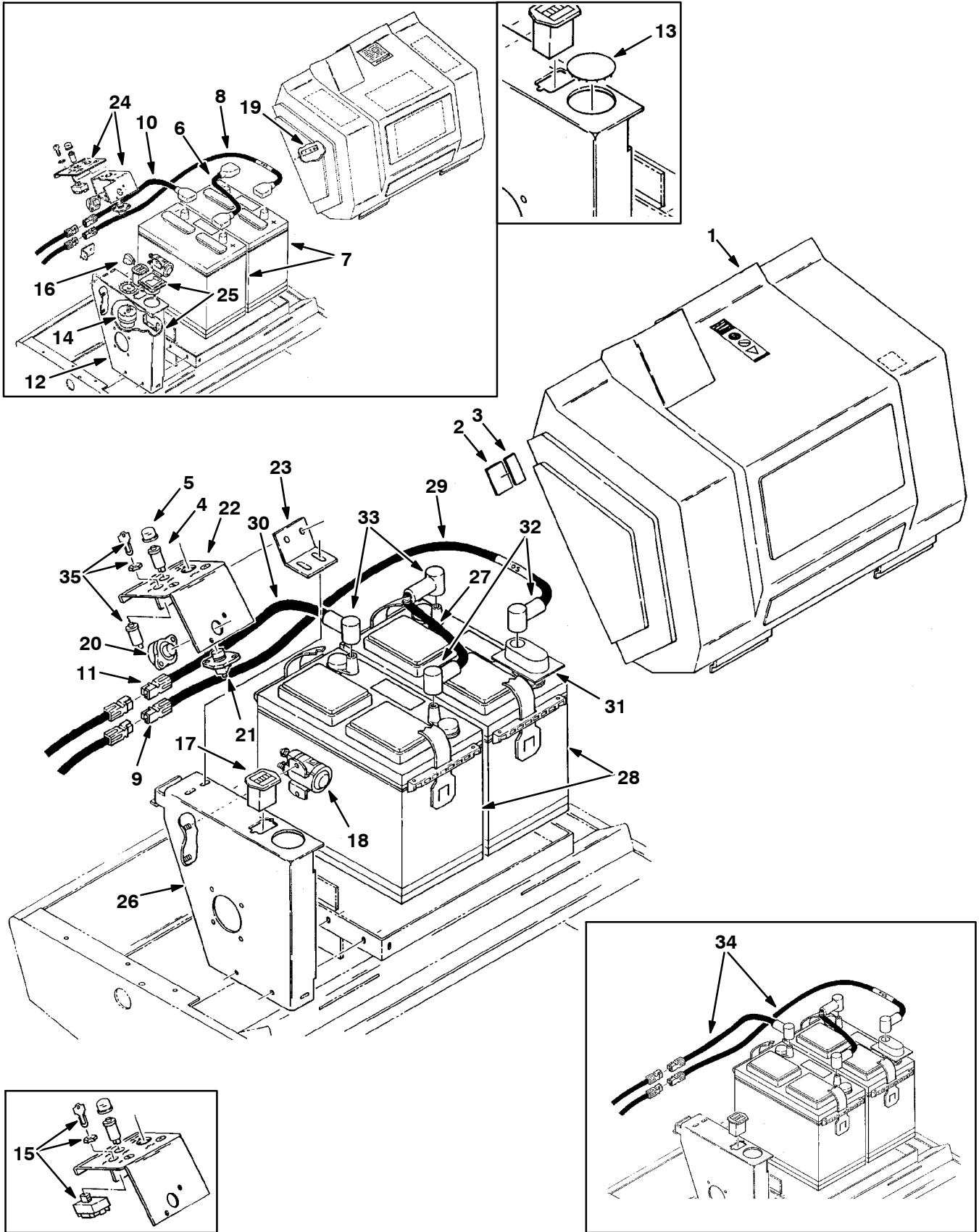

Fig. 9 - Battery Group

Fig. 9 - Battery Group

	Ref.	Tenant Part No.	Machine Serial Number	Description	Qty.
▽	1	02422	(006900-) Shroud	1
▲	2	08896	(008029-) Fastener, Velcro 1.0w Hook	2
▲	3	25953	(008029-) Fastener, Velcro, .5x1 White B	2
	4	57803	(006900-) Circuitbreaker, 15.0a, Resetable	1
	5	57751	(006900-) Boot, Circuitbreaker	1
	6	50480	(006900-010183) Cable, Battery, Blk 4ga 13.5l Pos/Neg	1
	7	61384	(006900-010183) Kit, Replmt, Battery,Wet F/10146	2
▽	8	41882	(006900-010183) Cable Assy, Battery, 6ga 18l Anderson	1
▲	9	12827	(006900-) Connector	1
▽	10	41883	(006900-010183) Cable Assy, Battery, 6ga 14l, [Anderson]	1
▲	11	12828	(006900-) Connector	1
	12	60593	(006900-009736) Panel, Fan, Spprt, Rework, [60495]	1
	13	82747	(009737-) Button, Plug, 2.09h .05-.06 [Black Stl]	1
	14	61104	(006900-009736) Switch Rep.By70089	1
▽	15	31203	(006900-013206) Switch Rep.By374227	1
▲		31204	(006900-013206) Key, Ignition, [Set Of 2], F/11651	1
	16	61106	(006900-009736) Knob Rep.Bynone	1
	17	377433	(006900-) Gauge, Hourmeter, 12-60Vdc, Analog [10K]	1
	18	02424	(006900-) Contactor, 24vdc	1
	19	60463	(006900-008028) Parts Unique, Hd Bmpr, Lpg, MI-D	2
	20	375119	(006900-) Circuitbreaker, 50.0 Amp, Resetable	1
	21	44078	(006900-) Switch	1
	22	25116	(008286-) Bracket, Mtg, Switch	1
	23	25115	(008286-) Angle, Sppt, Switch Bracket	1
	24	25118	(006900-008285) Kit, Replmt, Bracket	1
	25	29688	(006900-009736) Gauge, Ammeter, Chrgr, 24vdc	1
	26	60495	(009737-) Support Wldt, Fan	1
	27	61361	(010184-) Wire, 06ga 13.5l Blk .38ring /.31ring	1
	28	61355	(010184-) Battery, 12vdc, Wet	2
	29	61359	(010184-) Wire, 06ga 18.5l Red .38ring /Anderson	1
	30	61360	(010184-) Wire, 06ga 14.5l Blk .31ring /Anderson	1
	31	45962	(010184-) Cover, Terminal, Battery, Pye	4
	32	61364	(010184-) Boot, 90deg .62d .44d Red	2
	33	61365	(010184-) Boot, 90deg .62d .44d Black	2
	34	23287	(006900-012087) Kit, Replmt, Battery Harness	1
▽	35	222282	(013207-) Switch, Key, 12Vdc A Spdt	1
▲		222684	(013207-) Key, Set of Two	1

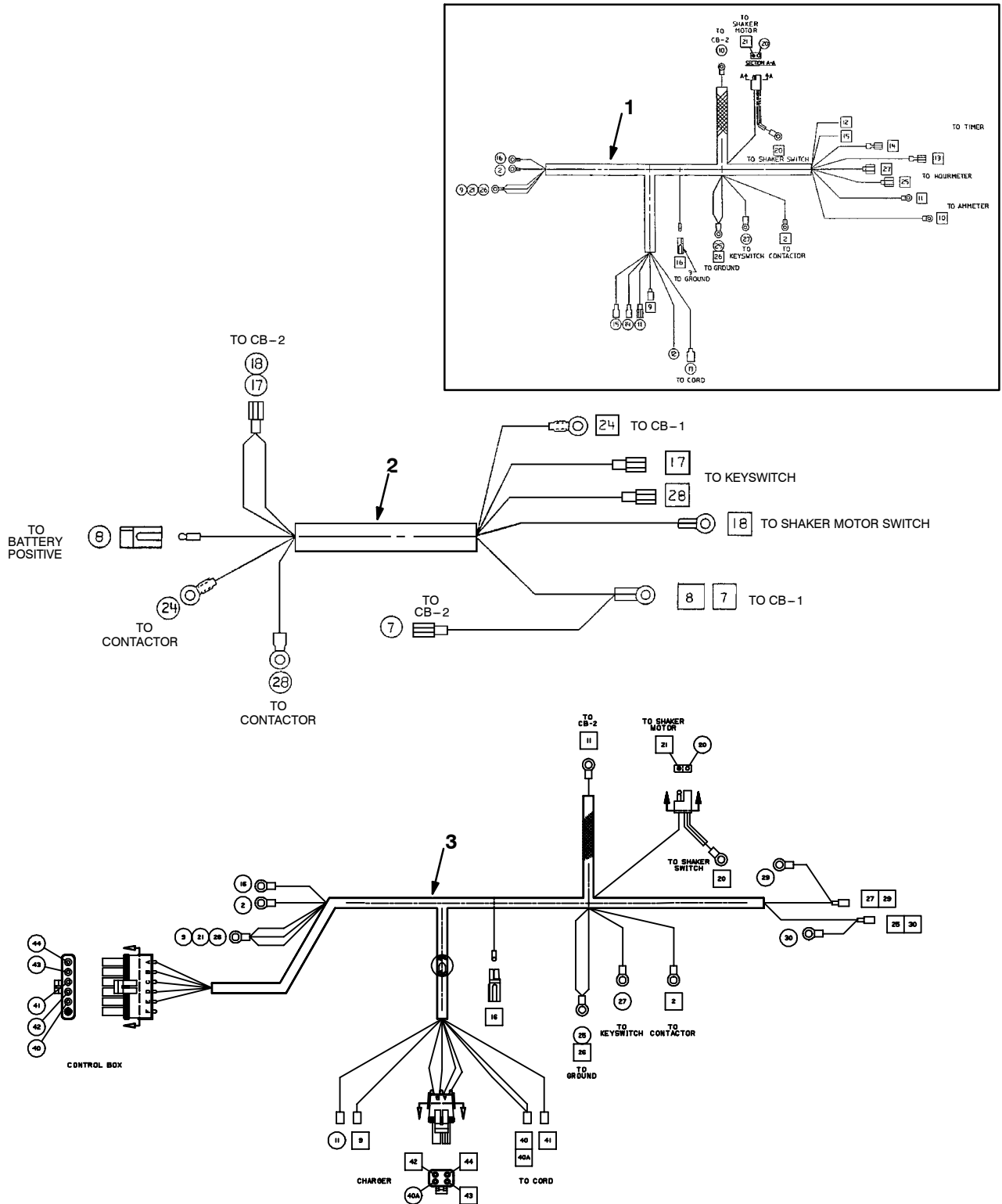

Fig. 10 - Wire Harnesses Group

Fig. 10 - Wire Harnesses Group

	Ref.	Tenant Part No.	Machine Serial Number	Description	Qty.
▽	1	02427	(006900-009736)	Harness, [140e], Fltr Shakr	1
▲		12828	(006900-009736)	Connector	1
▽	2	02432	(006900-	Harness, Controller, Shakr, [140e]	1
▲		12827	(006900-	Connector	1
	3	60487	(009737-	Harness, Main, [140e]	1

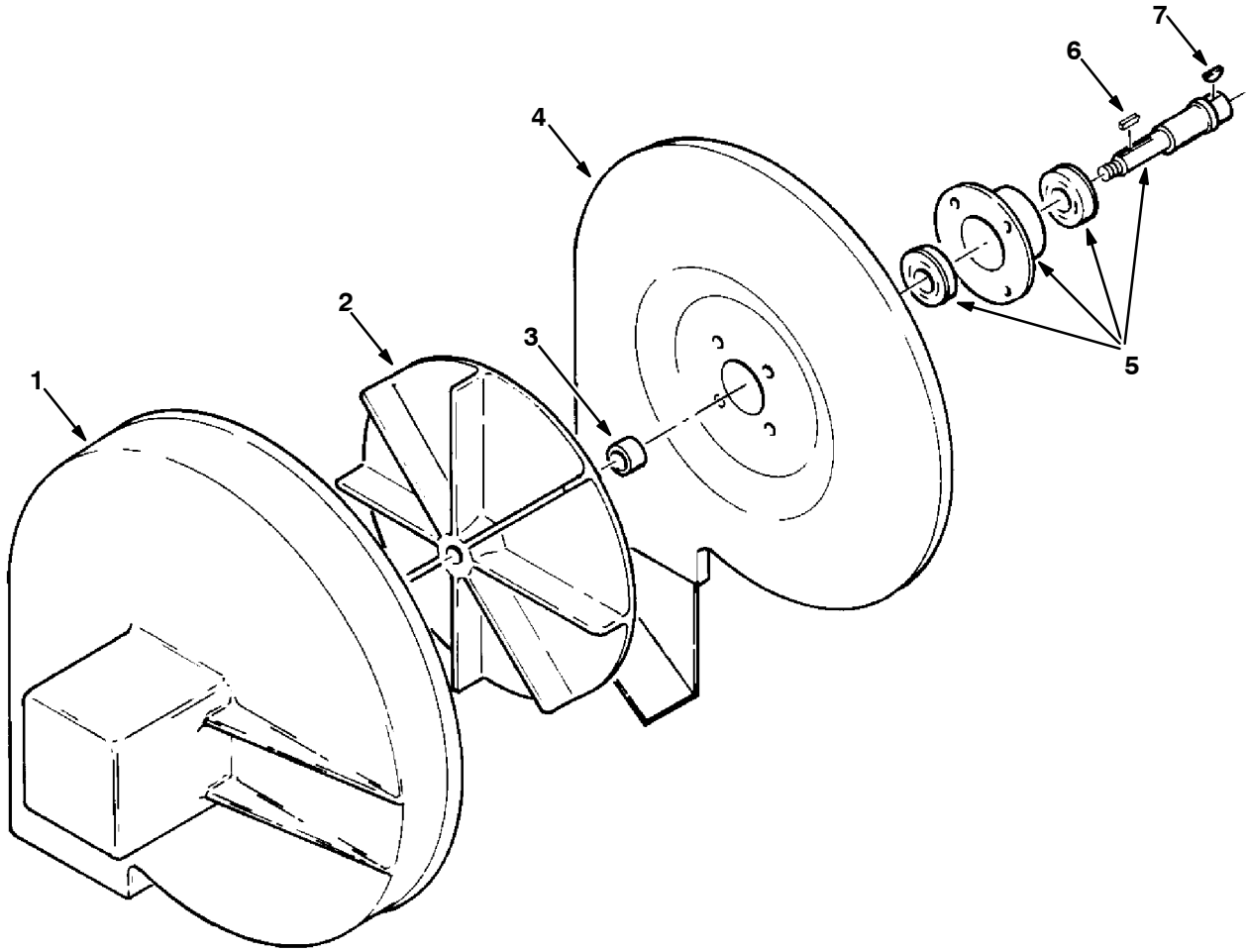

Fig. 11 - Vacuum Fan Group

01048

Ref.	Tennant Part No.	Machine Serial Number	Description	Qty.
1	41351	(006900-) Housing, Vacfan, Rear, 9.0d, Impeller	1
2	08143	(006900-) Impeller, 9.00d X 0.376b	1
3	10362	(006900-) Spacer	1
4	41582	(006900-) Panel Wldt, Backing, Vacfan	1
5	16934	(006900-) Shaft	1
6	00960	(006900-) Key, Sq, 0.12 X 0.12, 00.50l	1
7	00500-4	(006900-) Key, Woodruff, 0.12 0.50, [Asa#0404]	1

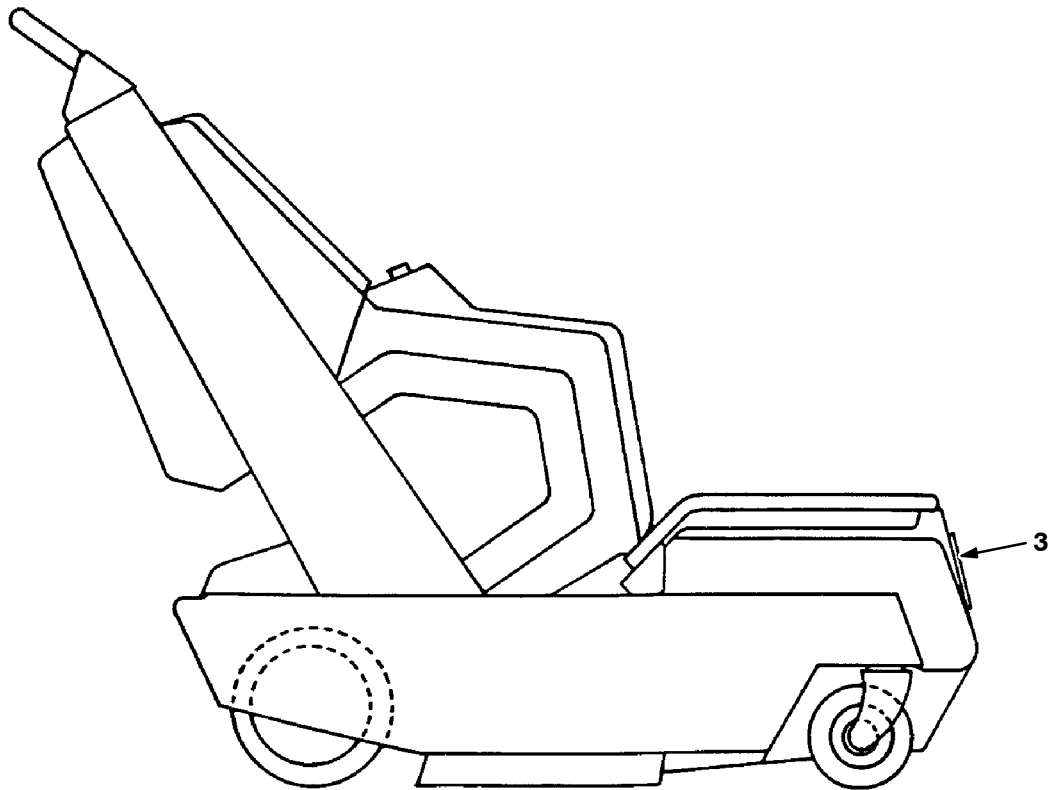
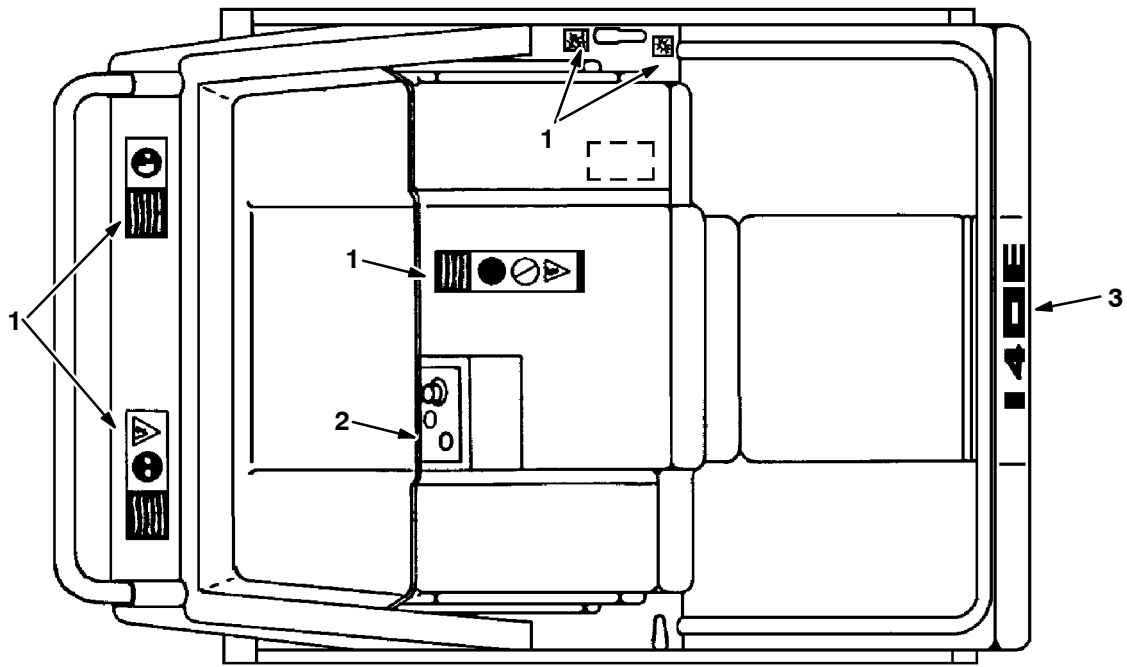

Fig. 12 - Label Kit

04655

Ref.	Tennant Part No.	Machine Serial Number	Description	Qty.
▽ 1	02575	(006900-)	Kit, Replmt, Label, Complt, [140e]	1
▲ 2	25117	(006900-)	Label, Opertnl, Instmt Panl,[140]	1
▲ 3	02560	(006900-)	Label, Numerals, [140/E] Black	1

SECTION 7

CONTENTS

	Page
Fig. 1 - Side Brush Group	7-2
Fig. 2 - Lifting Bracket Kit	7-4
Fig. 3 - Fine Particle Filter Kit	7-5
Fig. 4 - Dual Carpet Lint Filter Kit	7-6
Fig. 5 - Ammeter Group	7-7
Fig. 6 - Grille Kit	7-8
Fig. 7 - Cord Kit	7-9
Fig. 8 - Documentation Group	7-10

NOTE: SECTION 7, OPTIONS, lists repair parts included as part of the available options.

OPTIONS

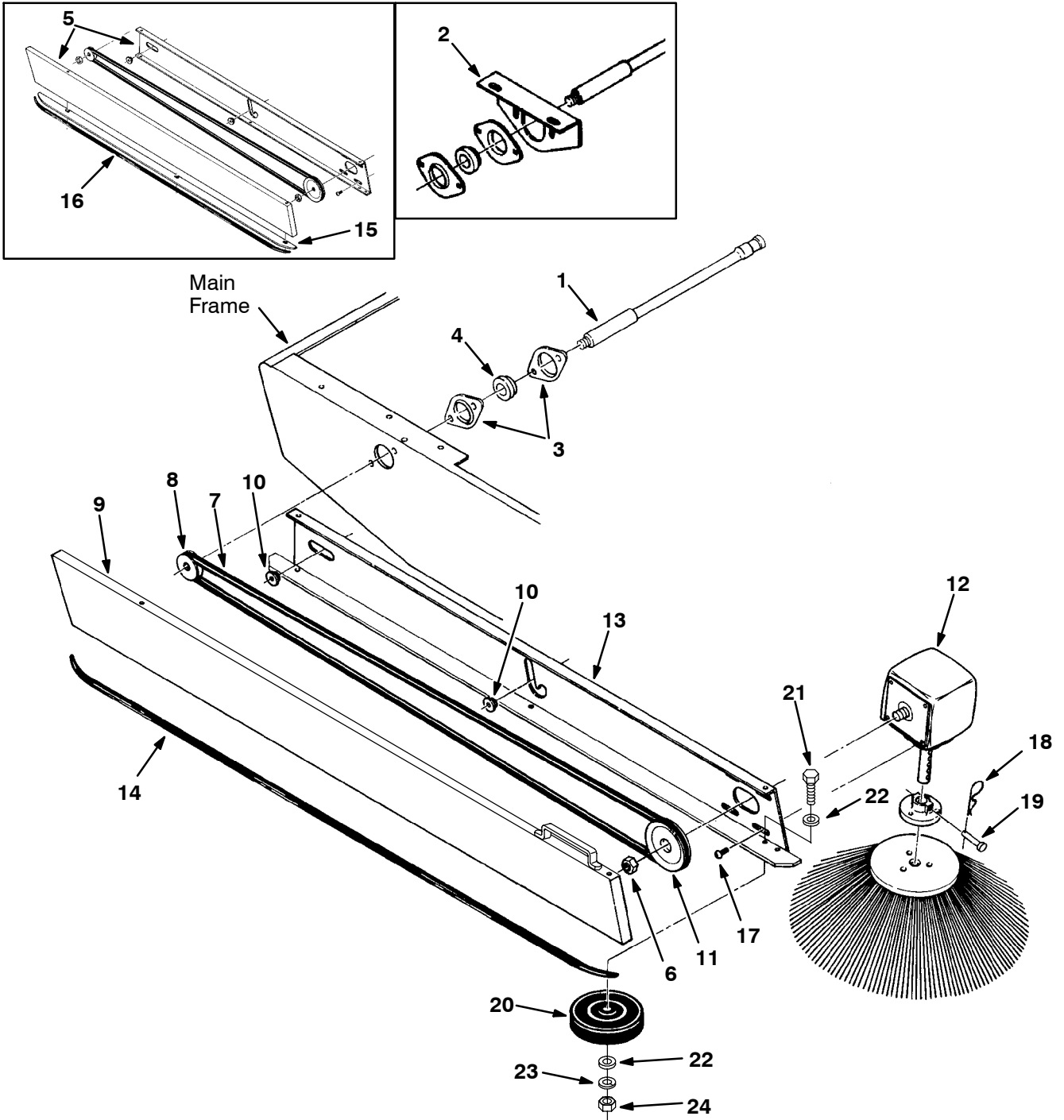

Fig. 1 - Side Brush Group

Fig. 1 - Side Brush Group

Ref.	Tennant Part No.	Machine Serial Number	Description	Qty.
1	48451	(003100-) Shaft, Drive, Brush, Side	1
2	48423	(003100-010239) Plate, Mtg, Bracket	1
3	48636	(003100-) Flange, Brg, 1.5id 2h	2
4	48635	(003100-) Bearing, W/ Collar, 0.63b 1.57d 1.12w	1
5	07894	(003100-008426) Arm, Brush, Side	1
6	39562	(003100-) Nut, Hex, Jam, .38-16, Lh	1
7	41678	(003100-) Belt, V, [3l] 80.0l	1
8	48452	(003100-) Sheave, [3l], 1grv, 01.4pd .38-16	1
9	07890	(008427-) Cover Wldt, Brush Arm	1
10	01047	(003100-) Retainer	2
11	07872	(003100-) Sheave, [3l], 1grv, 02.9pd .38-16	1
12	41731	(003100-) Gearbox, 90, :1ratio, Brush, Side	1
13	07891	(008427-) Arm, Brush, Side	1
14	07887	(008427-) Molding, Trim, .08-.11 39.20	1
15	41927	(003100-008426) Bumper, Side Brush	1
16	62595-14	(003100-008426) Molding, Trim, .08-.11 44.00	1
17	41708	(003100-) Screw, Btn, .25-20 X 0.62, NI	4
18	08085	(003100-) Pin, Hair Cotter, 0.31 D .058 Wir	1
19	15173	(003100-) Pin, Clevis, 0.25 D X 1.25l	1
▽	04188	(003100-) Wheel Assy, 4.0d 0.81w	1
▲	20 23295	(003100-) Wheel, 4.0d 0.81w 0.25b	1
▲	21 39528	(003100-) Screw, Hex, .25-20X2.00, 5	1
▲	22 32490	(003100-) Washer, Flat, 0.25 Std	2
▲	23 32982	(003100-) Washer, Lock, Int, .25	1
▲	24 19312	(003100-) Nut, Hex, Std, M10X1.5	1

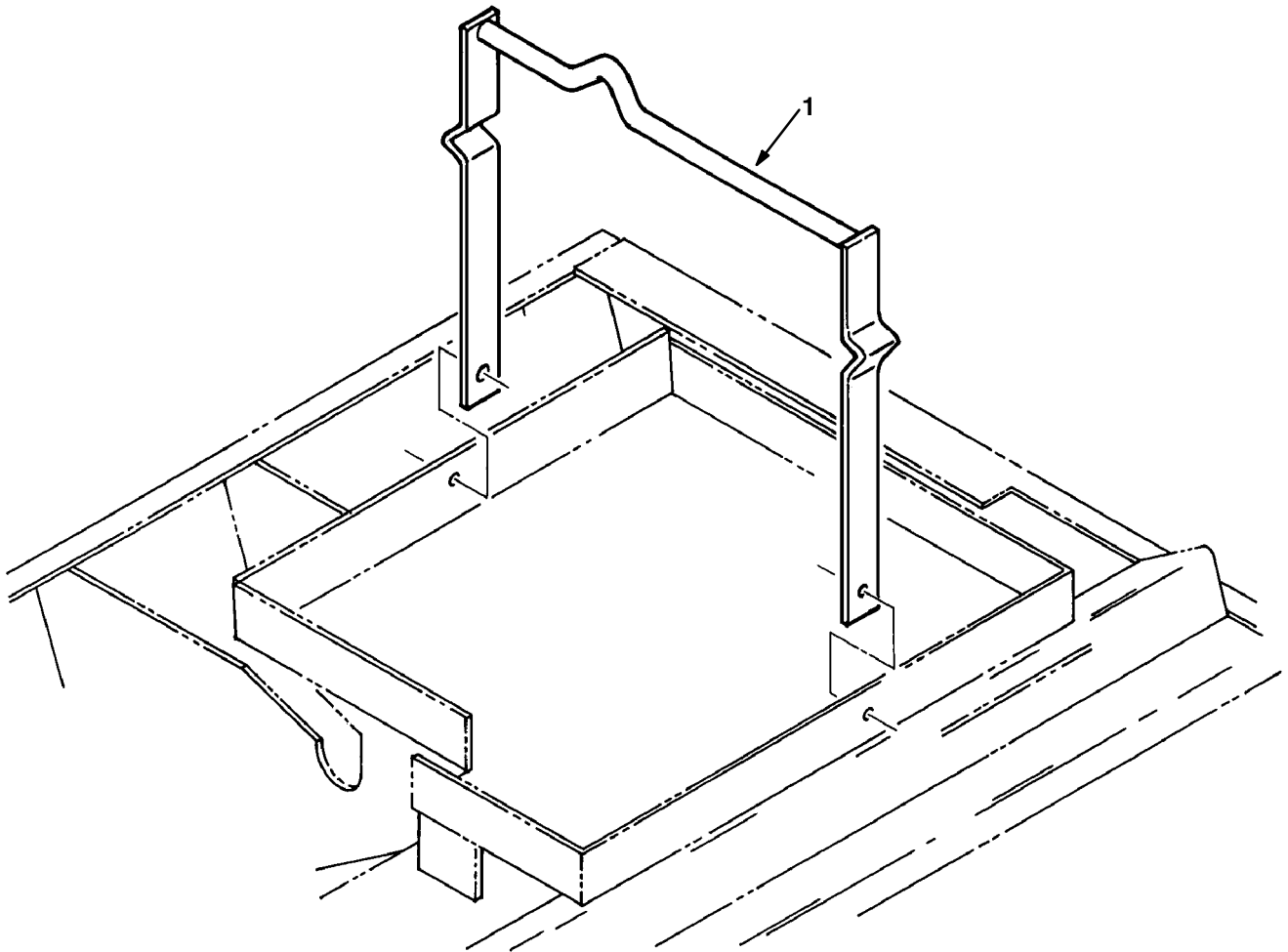

Fig. 2 - Lifting Bracket Kit

01033

	Ref.	Tennant Part No.	Machine Serial Number	Description	Qty.
▽		61121	(006900-) Kit, Demo, [140e]	1
▲	1	61117	(006900-) Bracket Wldt, Lift	1

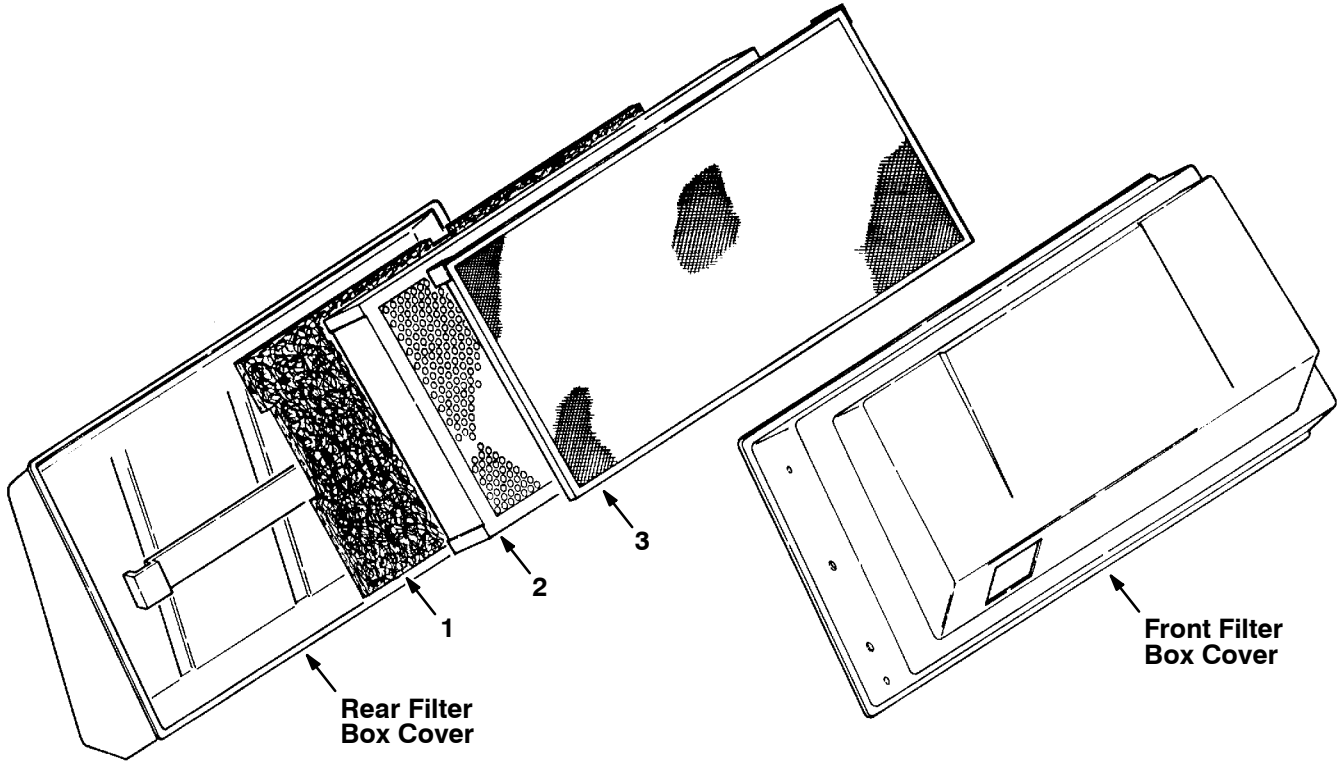
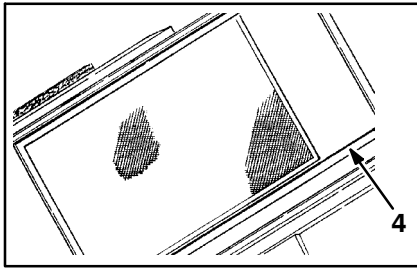

Fig. 3 - Fine Particle Filter Kit

02736

Ref.	Tennant Part No.	Machine Serial Number	Description	Qty.
▽	02594	(006900-)	Kit, Fltr, Extra Fine Particle [140e]	1
▲	1 65358	(006900-)	Screen, Filter	1
▲	2 60368	(006900-)	Filter Pkg, Dust, Panl, 119plts	1
▲	3 32557	(006900-)	Filter Pkg, Dust, Panl, Fine	1
▲	4 60378	(006900-007828)	Seal, Rbr, Open, 0.19th, 0.62w	1

OPTIONS

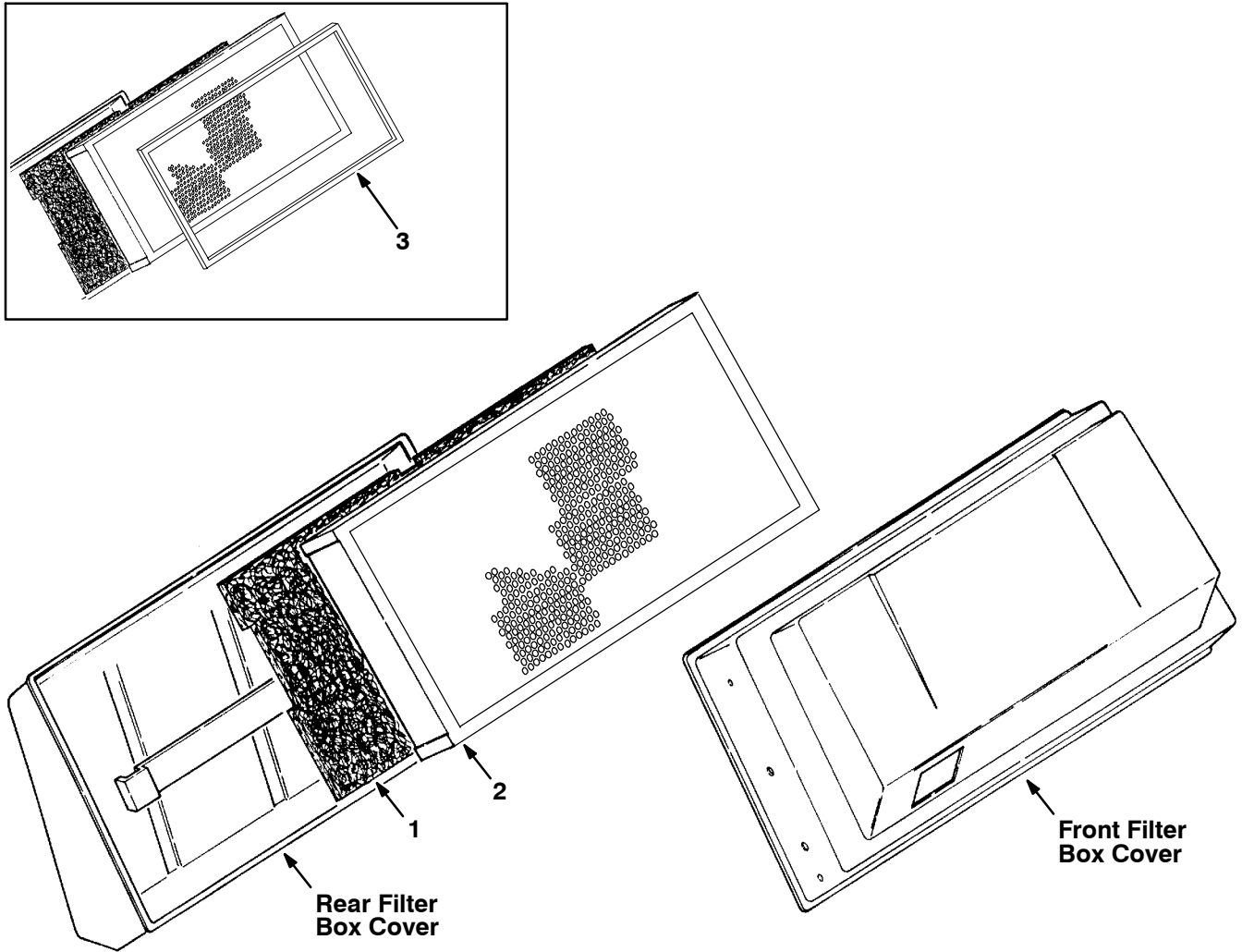

Fig. 4 - Dual Carpet Lint Filter Kit

Ref.	Tennant Part No.	Machine Serial Number	Description	Qty.
▽	398200	(006900-)	Kit, Filter, Dual, Carpet Lint	1
▲ 1	65358	(006900-)	Screen, Filter	1
▲ 2	60368	(006900-)	Filter Pkg, Dust, Panl, 119plts	1
▲ 3	60378	(006900-007828)	Seal, Rbr, Open, 0.19th, 0.62w	1

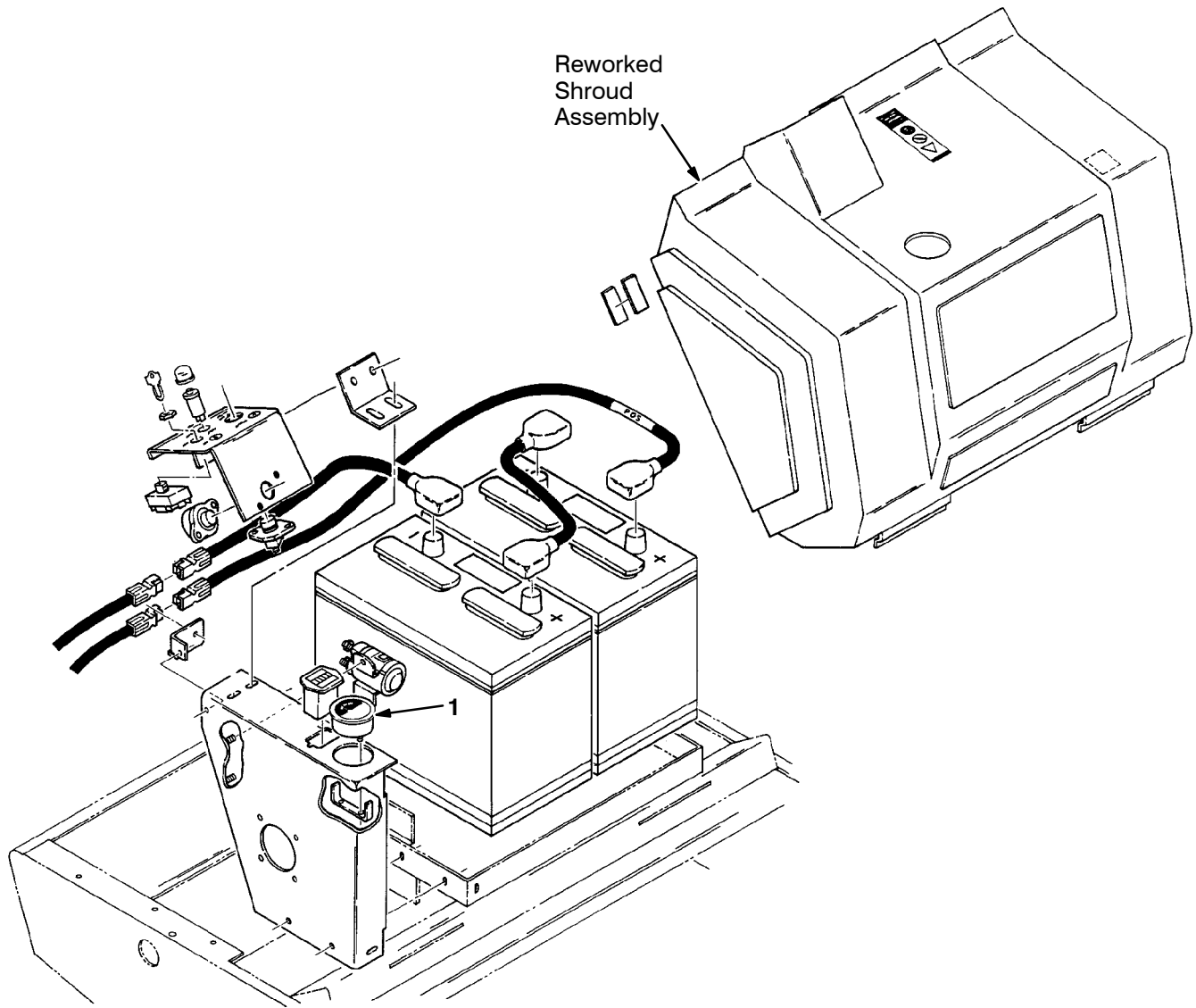

Fig. 5 - Ammeter Group

06993

Ref.	Tennant Part No.	Machine Serial Number	Description	Qty.
1	60510	(009737-) Gauge, Voltmeter, 16-36vdc 2.2d	1

NOTE: To identify parts shown but not listed here, see Section 5, Standard Model Parts.

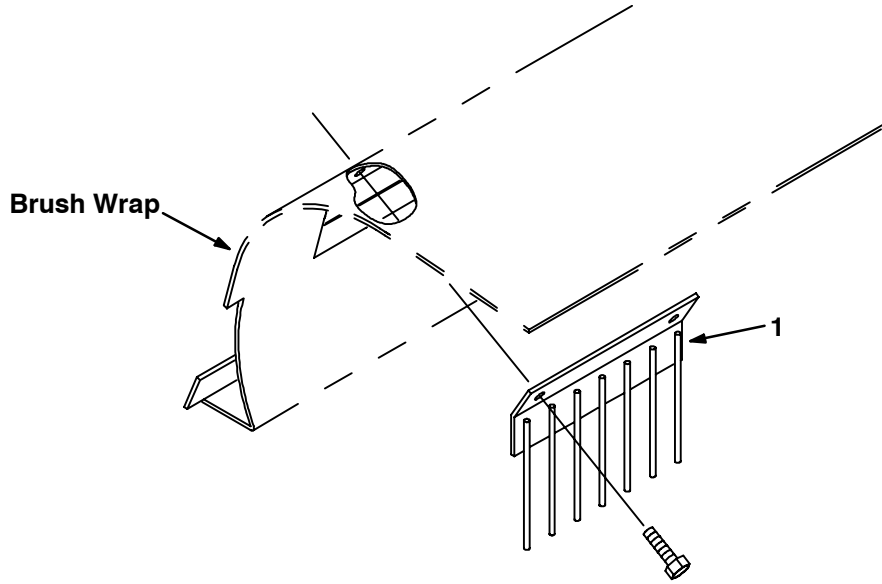

Fig. 6 - Grille Kit

06991

Ref.	Tennant Part No.	Machine Serial Number	Description	Qty.
1	25961	(006900-) Kit, Grille, Debris Deflector, [140]	1

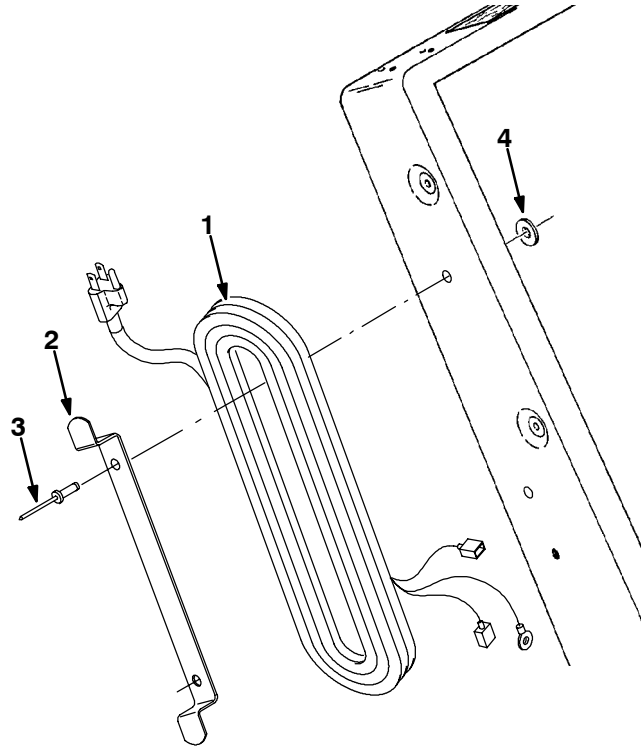
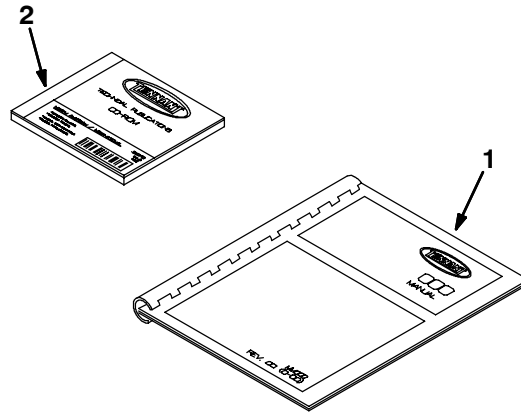

Fig. 7 - Cord Kit

Ref.	Tennant Part No.	Machine Serial Number	Description	Qty.
▽	50112	(006900-)	Kit, Cord, Chrgr, 10ft	1
▲	1 60565	(006900-)	Cord, Ele, 16-3 127.0inch	1
▲	2 41783	(006900-)	Bracket, Cord	1
▲	3 06524	(006900-)	Rivet, Blind, .196d X 0.62 X .38d, Alm	2
▲	4 61088	(006900-)	Washer, 0.19b 1.00d .06, Stl, Pl	2



07501

Fig. 8 - Documentation Group

Ref.	Tenant Part No.	Machine Serial Number	Description	Qty.
1	MM156	(006900-)	Manual Pkg, [140E Na 0006900-]	1
2	330710	(006900-)	Manual, Cd-Rom, Oprtr & Parts, All (Na)	1

SECTION 8

CONTENTS

PAGE

PART NUMBER TO PAGE NUMBER CROSS REFERENCE LIST 8-2
PART DESCRIPTION TO PAGE NUMBER CROSS REFERENCE LIST 8-4

CROSS REFERENCE

PART NUMBER TO PAGE NUMBER CROSS REFERENCE LIST

Part Number	Page Number	Part Number	Page Number	Part Number	Page Number
MM156	7-10	16925	6-13	36658	6-15
00500-1	6-13	16934	6-20	36661	6-15
00500-4	6-20	19312	7-3	36666	6-15
00911	6-13	20634	6-15	37490	6-13
00960	6-20	21198	6-11	375119	6-17
01047	7-3	222282	6-17	377412	6-13
01199	6-13	222684	6-17	377433	6-17
01513	6-13	23155	6-7	378964	6-13
01516	6-11	23243	6-3, 6-13	379000	6-8
01845	6-11	23279	6-3, 6-13	39019	6-11
01847	6-3, 6-7	23287	6-17	391838	6-13
02076	6-13	23295	7-3	39528	7-3
02355	6-11	23709	6-8	39562	7-3
02414	6-15	24227	6-11	398200	7-6
02421	6-15	24924	6-11	398207	6-9
02422	6-17	25115	6-17	40282	6-15
02424	6-17	25116	6-17	41142	6-11
02427	6-19	25117	6-21	41187	6-13
02432	6-19	25118	6-17	41351	6-20
02558	6-15	25147	6-11	41357	6-11
02560	6-21	25148	6-11	41360AM	6-11
02575	6-21	25950	6-11	41362	6-11
02592	6-3, 6-9	25953	6-17	41363	6-11
02594	7-5	25961	7-8	41385	6-11
03972	6-3	25997	6-13	41386	6-11
03973	6-3	26395-2	6-7	41396	6-3, 6-7
04007	6-7	28010	6-13	41411	6-11
04010	6-7	28013B	6-5	41434	6-13
04188	7-3	28499-2	6-7	41447	6-9
04594	6-13	28760	6-13	41448	6-9
04733-2	6-13	29091	6-13	41449	6-7
04756	6-7	29232	6-15	41457	6-5
06234	6-7	29260	6-11	41504	6-13
06460	6-13	29499	6-11	41509	6-11
06524	7-9	29688	6-17	41513	6-9
07872	7-3	31203	6-17	41518	6-11
07887	7-3	31204	6-17	41521	6-13
07890	7-3	31233	6-13	41549	6-15
07891	7-3	31271	6-15	41563	6-3, 6-9
07894	7-3	31905	6-13	41567-1	6-8
08085	7-3	31906	6-11	41568	6-9
08143	6-20	31912	6-8	41571	6-13
08868	6-8	31914	6-8	41573	6-15
08896	6-17	31918	6-8	41574	6-15
09006	6-11	32486	6-13	41582	6-20
09944	6-3, 6-7, 6-9	32490	7-3	41600	6-7
09945	6-11	32491	6-11, 6-13	41608	6-7
09971	6-11	32553	6-11	41612	6-15
10362	6-20	32556	6-15	41624	6-7
10819	6-13	32557	7-5	41637	6-11
12827	6-17, 6-19	32562	6-11	41648	6-11
12828	6-17, 6-19	32563	6-13	41649	6-11
12881	6-15	32856	6-5	41656	6-3, 6-15
15006	6-7	32862	6-3, 6-11	41665	6-8
15173	7-3	32982	7-3	41669	6-11
16230	6-3, 6-7	330710	7-10	41670	6-7
16232	6-3, 6-7	34217	6-15	41673	6-5
16237	6-11	34773	6-15	41678	6-3, 7-3

Part Number	Page Number	Part Number	Page Number
41701	6-7	57803	6-17
41708	7-3	59455	6-3
41731	7-3	60368	7-5, 7-6
41732	6-9	60378	6-3, 7-5, 7-6
41741	6-11	60426	6-8
41743	6-11	60428	6-8
41783	7-9	60463	6-17
41818	6-11	60487	6-19
41824A	6-15	60493	6-7
41827	6-7	60494	6-7
41828-1	6-13	60495	6-17
41829	6-8	60496	6-7
41832	6-8	60507	6-7
41837	6-3, 6-11	60510	7-7
41838	6-3, 6-15	60565	7-9
41839	6-15	60593	6-17
41840	6-3, 6-15	61035	6-13
41844	6-13	61046	6-7
41845	6-15	61088	6-3, 6-7, 7-9
41858	6-3, 6-15	61104	6-17
41863	6-13	61106	6-17
41864	6-11	61110	6-3, 6-7
41870	6-9	61117	7-4
41871	6-13	61121	7-4
41882	6-17	61355	6-17
41883	6-17	61359	6-17
41927	7-3	61360	6-17
43942	6-7	61361	6-17
44078	6-17	61364	6-17
44939	6-15	61365	6-17
45872	6-13	61377	6-8
45962	6-17	61379	6-8
46390AM	6-13	61384	6-17
47037	6-3	61487	6-13
47591	6-15	62595-14	7-3
47751	6-11	64757	6-7
48423	7-3	65358	7-5, 7-6
48451	7-3	70004	6-7
48452	7-3	82229	6-7
48635	6-13, 7-3	82747	6-17
48636	6-13, 7-3	86041	6-13
48661	6-15		
48662	6-15		
49266	6-7		
49566	6-11		
50038	6-11		
50040	6-13		
50049	6-7		
50050	6-7		
50066	6-13		
50090	6-13		
50111	6-13		
50112	7-9		
50116	6-7		
50122	6-13		
50456	6-7		
50480	6-17		
50609	6-7		
56060	6-11		
57751	6-17		

PART DESCRIPTION TO PAGE NUMBER CROSS REFERENCE LIST

A

Adaptor, Brush, Side, .628b, 6-5
 Adhesive, Contact, [1357 5.0oz], 6-3
 Angle, Sppt, Switch Bracket, 6-17
 Arm Assy, Brush, Main, [140], 6-11
 Arm Assy, Clutch, Propel, [140], 6-13
 Arm, Brush, Main, Drive, 6-11
 Arm, Brush, Main, Rh, 6-11
 Arm, Brush, Side, 7-3
 Arm, Clutch, Propel, Lh, 6-13
 Arm, Idler, Clutch, Propel, Rh, 6-13

B

Bar, Flt, Rbr, 0.06 X 1.00 X 4.00l, 6-15
 Bar, Flt, Rbr, 0.06 X 4.00 X 5.00l, 6-15
 Bar, Flt, Stl, 0.12 X 0.9 X 2.0 L, 6-8
 Bar, Hex, Stl, Mach, Sleeve, Idler, 6-11
 Battery, 12vdc, Wet, 6-17
 Bearing, Ball, 0.39b 1.18d 0.35w, 6-11
 Bearing, Ball, 0.59b 1.26d 0.35w, 6-11
 Bearing, Ball, 0.62b 1.38d 0.43w, 6-13
 Bearing, Ball, 0.67b 1.57d 0.47w, 6-13
 Bearing, Ball, 0.79b 1.85d 0.55w, 6-13
 Bearing, W/ Collar, 0.63b 1.57d 1.12w, 6-13, 7-3
 Belt, V, [3l] 36.0l, 6-3, 6-13
 Belt, V, [3l] 80.0l, 6-3, 7-3
 Belt, V, [3vx] 28.0l, 6-3, 6-11
 Belt, V, 6-3, 6-13
 Bolt, Carriage, .38-16 X 1.00, 6-13
 Bolt, Carriage, .38-16 X 2.00, 6-13
 Bolt, Shld, .38d X 1.00, .31-18, 6-11
 Boot, 90deg .50d .57d X .84, 6-13
 Boot, 90deg .62d .44d Black, 6-17
 Boot, 90deg .62d .44d Red, 6-17
 Boot, Circuitbreaker, 6-17
 Bracket / Wheel Assy, 6-7
 Bracket Wldt, Brush Lift, 6-11
 Bracket Wldt, Clutch, Propel, 6-13
 Bracket Wldt, Lift, 7-4
 Bracket Wldt, Motor, [Ohio], 6-13
 Bracket, Cord, 7-9
 Bracket, Mounting (Replaced by none), 6-7
 Bracket, Mtg, Caster, 6-7
 Bracket, Mtg, Cntrl Panl, 6-7
 Bracket, Mtg, Motor, [Prestolite], 6-13
 Bracket, Mtg, Spring, 6-11
 Bracket, Mtg, Switch, 6-17
 Bracket, Pivot, Fltr Cover, 6-15
 Bracket, Retainer, Fltr, Lh, 6-15
 Bracket, Retainer, Fltr, Rh, 6-15
 Bracket, Spacer, Battery, 6-7
 Brush Assy, Disk, Swp, 13.0 D, Pyp, 6-5
 Brush Holder, With Brushes, 6-13
 Brush, Motor, Set, 6-13
 Brush, Swp, 28l, 6 Dr, Pyp, 6-5
 Brush, Swp, 28l, 12 Sr, Umx Carpet, 6-5

Bumper, Rbr, 0.5d 0.14t Adh, 6-7
 Bumper, Side Brush, 7-3
 Bushing Assy, Flng, 2 Hole, 1.25b, 6-11
 Bushing, Flng, 0.28b 0.50d 0.50l, Pye, 6-8
 Bushing, Flng, 0.30b 0.52d . L, Nyl, 6-11
 Bushing, Flng, 0.62b 0.68d 0.00l, Nyl, 6-13
 Button, Plug, 2.09h .05-.06 [Black Stl], 6-17
 Button, Plug, 6-8

C

Cable Assy, Battery, 6ga 14l, [Anderson], 6-17
 Cable Assy, Battery, 6ga 18l Anderson, 6-17
 Cable, .13d, 28.5l, .25-20 /.38ball, 6-8
 Cable, Battery, Blk 4ga 13.5l Pos/Neg, 6-17
 Cap, Plug, 6-7
 Caster Rep.By23252, 6-7
 Caster, Stem, Swivel, 4.0 D, 6-7
 Catch, 6-8
 Chain, Sash, #35, 05.3l 09 Link, 6-7
 Charger, 24vdc 15a 50hz, 6-7
 Charger, 24vdc 015a 60hz 120vac Auto, 6-7
 Circuitbreaker, 15.0a, Resetable, 6-17
 Circuitbreaker, 50.0 Amp, Resetable, 6-17
 Clamp, Cable, Stl, 0.38d X 0.38w, 1h, 6-7
 Clip, Latch, 6-15
 Connector, 6-17, 6-19
 Contactor, 24vdc, 6-17
 Controlbox, Charger, 6-7
 Cord, Ele, 16-3 18.0inch, 6-7
 Cord, Ele, 16-3 127.0inch, 7-9
 Cover Wldt, Brush Arm, 7-3
 Cover, Filterbox, Front, W/ Logo, 6-15
 Cover, Filterbox, Rear, 6-15
 Cover, Flng, Drive, Gray, 6-11
 Cover, Frame, Rear, [140e], 6-7
 Cover, Terminal, Battery, Pye, 6-17
 Cup & Bearing Assy -Brush, 6-11
 Cup, Drive, Brush Tube-Grey, 6-11

D

Duct, Input, 6-15
 Duct, Outlet, 3.0 3.0 7.8l Pye, 6-15

F

Fastener, Velcro 1.0w Hook, 6-17
 Fastener, Velcro, .5x1 White B, 6-17

Filter Pkg, Dust, Panl, 119plts, 6-3, 6-15, 7-5, 7-6
 Filter Pkg, Dust, Panl, Fine, 7-5
 Flange, Brg, 1.5id 2h, 6-13, 7-3
 Frame Assy, F/[61010b], [140e], 6-7
 Frame Wldt, Main, [140/140e], 6-7
 Frame, Shaker, Fltr, [140e], 6-15

G

Gasket, Duct, Output, 6-3, 6-15
 Gasket, Duct, 6-3, 6-15
 Gauge, Ammeter, Chrgr, 24vdc, 6-17
 Gauge, Hourmeter, 12-60Vdc, Analog [10K], 6-17
 Gauge, Voltmeter, 16-36vdc 2.2d, 7-7
 Gearbox, 90, :1ratio, Brush, Side, 7-3
 Guard, Cup, Gray, 6-11

H

Handle Assy, Tube, 1.00d 24.9w, 6-8
 Handle Assy, W/ Label, [140], 6-8
 Handle, Clutch, 6-8
 Handle, Hppr, 6-9
 Handle, Lift, Brush, [140], 6-11
 Handle, 6-7
 Harness, [140e], Fltr Shkr, 6-19
 Harness, Controller, Shkr, [140e], 6-19
 Harness, Main, [140e], 6-19
 Hinge, Pyp, .06 2.0 W 03.3l 4/0.34h, 6-3, 6-11
 Hopper Assy, [140/140e/141e], 6-9
 Housing, Vacfan, Rear, 9.0d, Impeller, 6-20

I

Idler Arm, 6-11
 Impeller, 9.00d X 0.376b, 6-20
 Insulation, Acstc, 1.0th, 03.9w X 04.8l, 6-15

K

Key, Ignition, [Set Of 2], F/11651, 6-17
 Key, Set of Two, 6-17
 Key, Sq, 0.12 X 0.12, 00.50l, 6-20
 Key, Sq, 0.19 X 0.19, 00.75l, 6-13
 Key, Woodruff, 0.09 0.50, [Asa#0304], 6-13
 Key, Woodruff, 0.12 0.50, [Asa#0404], 6-20
 Kit, Filter, Dual, Carpet Lint, 7-6
 Kit, Cord, Chrgr, 10ft, 7-9
 Kit, Demo, [140e], 7-4
 Kit, Fltr, Extra Fine Particle [140e], 7-5
 Kit, Grille, Debris Deflector, [140], 7-8
 Kit, Maint, Seals, Gas, [140], 6-3
 Kit, Maint, Skirt, Gas, [140], 6-3

Kit, Replmt, Arm, Clutch, F/ 41611, 6-13
 Kit, Replmt, Battery Harness, 6-17
 Kit, Replmt, Battery,Wet F/10146, 6-17
 Kit, Replmt, Bearing,F/41646, 6-13
 Kit, Replmt, Bracket, 6-17
 Kit, Replmt, Cable Guide, Clutch, 6-8
 Kit, Replmt, Chrgr, F/ 50708, 6-7
 Kit, Replmt, Chrgr, F/ 50709, 6-7
 Kit, Replmt, Frame, F/ 48625-1, 6-8
 Kit, Replmt, Frame, F/ 09003, 6-8
 Kit, Replmt, Handle / Bracket, 6-11
 Kit, Replmt, Idler Arm, F/ 41817, 6-11
 Kit, Replmt, Idler, F/ [41819&47], 6-11
 Kit, Replmt, Idler, F/31230/1/2, 6-13
 Kit, Replmt, Label, Complt, [140e], 6-21
 Kit, Replmt, Shaft, F/39571, 6-13
 Knob Rep.Bynone, 6-17

L

Label, Numerals, [140/E] Black, 6-21
 Label, Opertnl, Instmt Panl,[140], 6-21

M

Manual Pkg, [140E Na 0006900-], 7-10
 Manual, Cd-Rom, Oprtr & Parts, All (Na), 7-10
 Molding, Trim, .08-.11 39.20, 7-3
 Molding, Trim, .08-.11 44.00, 7-3
 Molding, Trim, Rubber, .06 1.4l, 6-9
 Motor Rep. By 50091, 6-13
 Motor, Ele, 36vdc Hp Shaker, 6-15
 Motor, Ele, .8hp, 6-13
 Motor, Ele, 24Vdc 0.75Hp 2100Rpm 28.0A, 6-13

N

Nut, Hex, Jam, .38-16, Lh, 7-3
 Nut, Hex, Std, M10X1.5, 7-3
 Nut, Isolator, .25-20 #1/4-S, 6-15
 Nut, Speed, Retainer, .25-20, 6-8
 Nut, U, .25-20, 6-3, 6-7

P

Panel Wldt, Backing, Vacfan, 6-20
 Panel, Brush, 6-7
 Panel, Fan, Spprt, Rework, [60495], 6-17
 Parts Unique, Hd Bmpr, Lpg, MI-D, 6-17
 Pin, Clevis, 0.25 D X 1.25l, 7-3
 Pin, Clevis, 0.37 D X 0.62l, 6-13
 Pin, Clevis, 0.37 D X 0.75l, 6-11
 Pin, Hair Cotter, 0.31 D .058 Wir, 7-3
 Plate Rep.Bynone, 6-11
 Plate, Mtg, Bracket, 7-3
 Plate, 6-11

R

Replmt.Parts Pkg 140e, 6-3
 Retainer Rep.By61381, 6-15
 Retainer, Seal, W/ Label, Rear, 6-9
 Retainer, Skirt, Hppr, Rear,, 6-9
 Retainer, 6-15, 7-3
 Ring, Retaining, Ext, 0.59d, Basic, 6-11
 Ring, Retaining, Int, 1.38d, Basic, 6-13
 Rivet, Blind, .188D X 0.45 X .38D, Stl, 6-9
 Rivet, Blind, .188D X 0.58 X .38d, Stl, 6-8
 Rivet, Blind, .196d X 0.62 X .38d, Alm, 7-9
 Rod, Thrd, Full, .31-18 05.7l, 6-11
 Rod, 6-8

S

Screen, Filter, 7-5, 7-6
 Screw, Btn, .25-20 X 0.62, NI, 7-3
 Screw, Hex, .25-20X2.00, 5, 7-3
 Screw, Hex, .38-16 X 1.00, Lh, 6-13
 Screw, Hex, .38-16 X 1.25, 5, 6-11
 Screw, Hex, .50-13 X 6.50, 2, Unpl, 6-13
 Screw, Set, #10-24 X 0.25, NI, 6-15
 Seal, Foam, Rbr, .38 0.75w 94.0l, 6-3, 6-15
 Seal, Foam, Rbr, .50 0.75w 03.0l, 6-11
 Seal, Rbr, Open, 0.19th, 0.62w 04.6l, 6-3, 6-9
 Seal, Rbr, Open, 0.19th, 0.62w, 6-3, 7-5, 7-6
 Shaft, Cntrl, Clutch, 6-13
 Shaft, Drive, Brush, Side, 7-3
 Shaft, 6-11, 6-20
 Shaker, Filter, Dust, 6-15
 Sheave, [3l], 1grv, 01.4pd .38-16, 7-3
 Sheave, [3l], 1grv, 01.6pd 0.62b, 6-13
 Sheave, [3l], 1grv, 01.8pd 0.62b, 6-13
 Sheave, [3l], 1grv, 02.9pd .38-16, 7-3
 Sheave, [3l], 1grv, 06.4pd 0.38b, 6-13
 Sheave, [3v], 1grv, 02.2pd 0.38b, 6-13
 Sheave, [3v], 1grv, 03.0pd 0.38brg, 6-11
 Sheave, [3v], 1grv, 03.5pd 0.38b, 6-11
 Sheave, Flat, 1.8d 1.38w 0.67b, 6-13
 Shield, Hppr, 6-9
 Shroud, 6-17
 Skirt, .06th, 10.00w 30.00l, 06/0.31h, 6-3, 6-9
 Skirt, 6-3, 6-7, 6-9
 Sleeve, 6-7, 6-11, 6-13, 6-15
 Spacer, 6-20
 Spring, Cmpr, 0.72od .55wir 3.0l, 6-11
 Spring, Extn, 0.75od X 0.06wir, 5.3l, 6-11
 Spring, Extn, 0.75od X 0.11wir, 4.5l, 6-11
 Strainrelief, 6-15
 Strap, 6-15
 Strip, Stl, 0.07th X 00.90w, 03.30l, 6-11
 Strip, 6-7
 Support Wldt, Fan, 6-17

Switch Rep.By374227, 6-17
 Switch Rep.By70089, 6-17
 Switch, Key, 12Vdc A Spdt, 6-17
 Switch, 6-17

T

Terminal, Qdc, [.25f, Ins ,14], 6-7
 Terminal, Qdc, [.25m, Insf,10], 6-7
 Terminal, Qdc, [.25m, Inss,], 6-7
 Tie, Cable, Nyl, 07.3l .19w 1.8 Max D, 6-7
 Tire Assy, Solid, 08.0x2.0 1.37b, 6-13
 Tire Assy, Solid, 08.0x2.0 , W/ Brg, 6-13
 Tray, 6-7
 Tube, Steel, 6-13

W

Washer, 0.19b 1.00d .06, Stl, Pl, 6-3, 6-7, 7-9
 Washer, 0.28b 0.62d .06, Nyl, 6-11
 Washer, 0.38b 0.56d .03, Stl, 6-11
 Washer, Belleville, .38, 6-13
 Washer, Flat, 0.25 Std, 7-3
 Washer, Flat, 6-11
 Washer, Flt, .31 Std, 6-11, 6-13
 Washer, Flt, .50 Sae, 6-13
 Washer, Lock, Int, .25, 7-3
 Washer, Lock, Int-Ext, .38, 6-11
 Washer, 6-11
 Weight, Eccentric, 6-15
 Wheel Assy, 4.0d 0.81w, 7-3
 Wheel, 1.6d 0.72w 0.21b, 6-3, 6-7
 Wheel, 4.0d 0.81w 0.25b, 7-3
 Wire, 06ga 13.5l Blk .38ring /.31ring, 6-17
 Wire, 06ga 14.5l Blk .31ring /Anderson, 6-17
 Wire, 06ga 18.5l Red .38ring /Anderson, 6-17
 Wire, 6-7



TENNANT COMPANY
 Technical Publications #15
 701 North Lilac Drive
 P.O. Box 1452
 Minneapolis, MN 55440-9947

POSTAGE WILL BE PAID BY ADDRESSEE

BUSINESS REPLY MAIL
 FIRST CLASS MAIL PERMIT NO. 94 MINNEAPOLIS, MN

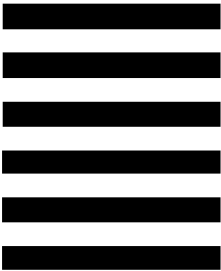

NO POSTAGE
 NECESSARY
 IF MAILED
 IN THE
 UNITED STATES

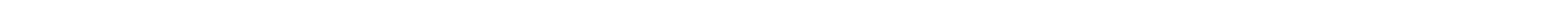
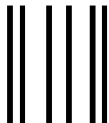

Fold along dotted lines

Tape here

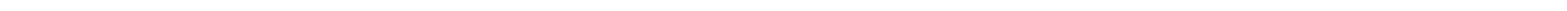



TENNANT COMPANY
 Technical Publications #15
 701 North Lilac Drive
 P.O. Box 1452
 Minneapolis, MN 55440-9947

POSTAGE WILL BE PAID BY ADDRESSEE

BUSINESS REPLY MAIL
 FIRST CLASS MAIL PERMIT NO. 94 MINNEAPOLIS, MN

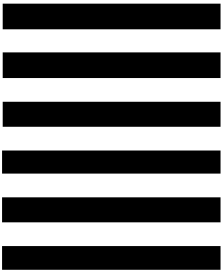

NO POSTAGE
 NECESSARY
 IF MAILED
 IN THE
 UNITED STATES

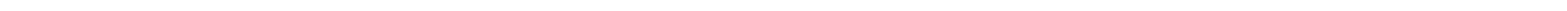
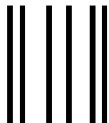

Fold along dotted lines

Tape here

